

Vespa®

MANUALE STAZIONE DI SERVIZIO



Vespa GTS Super 300 ie (2008)



MANUALE STAZIONE DI SERVIZIO

Vespa GTS Super 300 ie (2008)

The descriptions and illustrations given in this publication are not binding. While the basic specifications as described and illustrated in this manual remain unchanged, PIAGGIO-GILERA reserves the right, at any time and without being required to update this publication beforehand, to make any changes to components, parts or accessories, which it considers necessary to improve the product or which are required for manufacturing or construction reasons.

Not all versions/models shown in this publication are available in all countries. The availability of single versions should be checked at the official Piaggio sales network.

"© Copyright 2007 - PIAGGIO & C. S.p.A. Pontedera. All rights reserved. Reproduction of this publication in whole or in part is prohibited."

PIAGGIO & C. S.p.A. - After-Sales

V.le Rinaldo Piaggio, 23 - 56025 PONTEDERA (Pi)

MANUALE STAZIONE DI SERVIZIO

Vespa GTS Super 300 ie (2008)

This service station manual has been drawn up by Piaggio & C. Spa to be used by the workshops of Piaggio-Gilera dealers. It is assumed that the user of this manual for maintaining and repairing Piaggio vehicles has a basic knowledge of mechanical principles and vehicle repair technique procedures. Any significant change to vehicle characteristics or to specific repair operations will be communicated by updates to this manual. Nevertheless, no mounting work can be satisfactory if the necessary equipment and tools are unavailable. It is therefore advisable to read the sections of this manual concerning special tools, along with the special tool catalogue.

N.B. Provides key information to make the procedure easier to understand and carry out.

CAUTION Refers to specific procedures to carry out for preventing damages to the vehicle.

WARNING Refers to specific procedures to carry out to prevent injuries to the repairer.



Personal safety Failure to completely observe these instructions will result in serious risk of personal injury.



Safeguarding the environment Sections marked with this symbol indicate the correct use of the vehicle to prevent damaging the environment.



Vehicle intactness The incomplete or non-observance of these regulations leads to the risk of serious damage to the vehicle and sometimes even the invalidity of the guarantee.



INDEX OF TOPICS

CHARACTERISTICS

CHAR

TOOLING

TOOL

MAINTENANCE

MAIN

TROUBLESHOOTING

TROUBL

ELECTRICAL SYSTEM

ELE SYS

ENGINE FROM VEHICLE

ENG VE

ENGINE

ENG

INJECTION

INJEC

SUSPENSIONS

SUSP

BRAKING SYSTEM

BRAK SYS

COOLING SYSTEM

COOL SYS

CHASSIS

CHAS

PRE-DELIVERY

PRE DE

TIME

TIME

INDEX OF TOPICS

CHARACTERISTICS

CHAR

This section describes the general specifications of the vehicle.

Rules

This section describes general safety rules for any maintenance operations performed on the vehicle.

Safety rules

- If work can only be done on the vehicle with the engine running, make sure that the premises are well-ventilated, using special extractors if necessary; never let the engine run in an enclosed area. Exhaust fumes are toxic.
 - The battery electrolyte contains sulphuric acid. Protect your eyes, clothes and skin. Sulphuric acid is highly corrosive; in the event of contact with your eyes or skin, rinse thoroughly with abundant water and seek immediate medical attention.
 - The battery produces hydrogen, a gas that can be highly explosive. Do not smoke and avoid sparks or flames near the battery, especially when charging it.
 - Fuel is highly flammable and it can be explosive given some conditions. Do not smoke in the working area, and avoid naked flames or sparks.
 - Clean the brake pads in a well-ventilated area, directing the jet of compressed air in such a way that you do not breathe in the dust produced by the wear of the friction material. Even though the latter contains no asbestos, inhaling dust is harmful.
-

Maintenance rules

- Use original PIAGGIO spare parts and lubricants recommended by the Manufacturer. Non-original or non-conforming spares may damage the vehicle.
 - Use only the appropriate tools designed for this vehicle.
 - Always use new gaskets, sealing rings and split pins upon refitting.
 - After removal, clean the components using non-flammable or low flash-point solvents. Lubricate all the work surfaces, except tapered couplings, before refitting these parts.
 - After refitting, make sure that all the components have been installed correctly and work properly.
 - For removal, overhaul and refit operations use only tools with metric measures. Metric bolts, nuts and screws are not interchangeable with coupling members with English sizes. Using unsuitable coupling members and tools may damage the scooter.
 - When carrying out maintenance operations on the vehicle that involve the electrical system, make sure the electric connections have been made properly, particularly the ground and battery connections.
-

Vehicle identification

Chassis prefix: ZAPM45100000 ÷ 1001

Engine prefix: M451M ÷ 1001

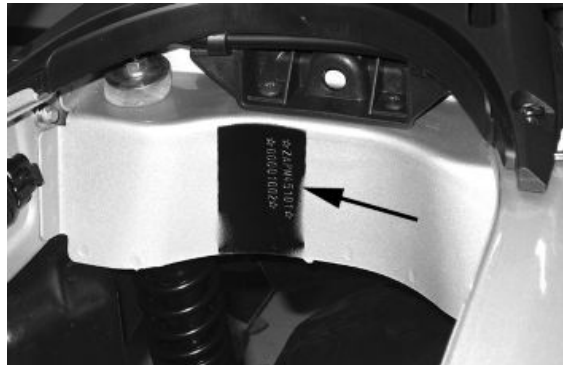

Dimensions and mass

WEIGHTS AND DIMENSIONS

Specification	Desc./Quantity
Kerb weight	158 ± 5 kg
Maximum weight allowed	340 kg
Maximum height	1170 mm
Overall width	755 mm
Overall length	2230 mm
Wheelbase	1370 mm

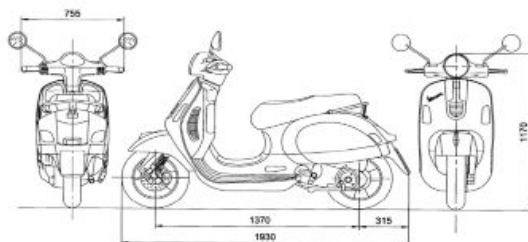

Engine

DATA

Specification	Desc./Quantity
Type	single-cylinder, four-stroke and four liquid-cooled valves
Cubic capacity	278.3 cm ³
Stroke	63 mm
Bore	75 mm
MAX. torque	22 Nm at 6500 rpm
Max. Power	16.4 kW at 7500 rpm
Timing system	single overhead camshaft chain driven on the left-hand side, 3-arm rocking levers set up with set screw
Compression ratio	10.5 ÷ 11.5
Engine idle speed	1650 ± 50 rpm
Air filter	sponge, impregnated with mixture (50% petrol and 50% oil)
Starting system	electric starter motor with freewheel
Lubrication	with lobe pump (inside the crankcase) controlled by a chain and double filter: mesh and paper
Fuel supply	Electronic injection with electric fuel pump
valve clearance	intake: 0.10 mm - discharge: 0.15 mm
Minimum lubrication pressure (100° C)	0.8 bar
Lubrication pressure	3.5 ÷ 4 bar
Cooling	Forced liquid circulation cooling.

OIL PUMP

Specification	Desc./Quantity
Type	Trochoidal
Distance between the rotors	Admissible limit clearance: 0.12 mm
Axial rotor clearance	Limit values admitted: 0.09 mm
Distance between the outer rotor and the pump body	Admissible limit clearance: 0.20 mm
Levelness	0.1 mm

BY-PASS

Specification	Desc./Quantity
Type	With piston
Plunger diameter	Ø 13.9 - 0.039 -0.057 mm
By-pass check up: Standard length	54.2 mm
Calibration pressure	4.5 bar

OIL FILTER

Specification	Desc./Quantity
Type	Paper with pressure relief and anti-drain back by-pass valves

OIL MINIMUM PRESSURE INDICATOR LIGHT SWITCH

Specification	Desc./Quantity
Calibration	0.3 - 0.6 bar

HEAD LUBRICATION CONTROL JET

Specification	Desc./Quantity
Diameter	1 ± 0.05 mm *

* Tightening torque 5÷7 N.m

COOLING SYSTEM

Specification	Desc./Quantity
Cooling system capacity	~ 2.100 ÷ 2.150 l
Prescribed fluid	AGIP PERMANENT SPEZIAL
Sealing pressure	Cap calibrated at 0.9 bar

THERMOSTAT

Specification	Desc./Quantity
Type	Wax-type, with deviator
Starts opening	85±2°C

ELECTRIC VENTILATION

Specification	Desc./Quantity
Electric ventilation starts at	102°C
Electric ventilation stops at	96°C

WATER PUMP

Specification	Desc./Quantity
Type	Centrifugal
Control	Coaxial to crankshaft

RADIATOR

Specification	Desc./Quantity
Type	Made of aluminium in two sections

Transmission**TRANSMISSION**

Specification	Desc./Quantity
Transmission	Automatic expandable pulley variator with torque server, V belt, automatic clutch, gear reduction unit and transmission housing with forced air circulation cooling

Capacities**CAPACITY**

Specification	Desc./Quantity
Fuel tank (including a ~ 2 l reserve)	~ 9.2 l
Cooling system fluid	~ 2.100 ÷ 2.150 l
Engine oil	approx. 1300 cc
Rear hub	250 cc

Electrical system**ELECTRICAL COMPONENTS**

Specification	Desc./Quantity
Ignition/advance	Electronic, with inductive discharge and variable advance with three-dimensional mapping
Spark plug	CHAMPION RG 4 PHP
Battery	12V-12Ah
Fuses	One 30A fuse - One 15A fuse - Three 10A fuses - Four 7.5A fuses - One 3A fuse
Generator	alternating current

CHECKING REMOTE CONTROLS «A» OPERATING AS CIRCUIT BREAKERS

- 1) Check that, given regular conditions, there is no continuity between terminals 30 and 87.
- 2) Apply 12V voltage to power terminals 85 and 86 of the remote control.
- 3) With the remote control powered, check that there is continuity between terminals 30 and 87.
- 4) If these conditions are not fulfilled, the remote control is damaged and must be replaced.



To check buttons and switches, check that, according to their position, the continuity of contacts is correct as indicated in the following charts.

TURN INDICATOR SWITCH

	Ro	Bl-Ne	Bi-BI
←	○—○		
↔ STOP ↔			
→		○—○	

ENGINE STOP SWITCH

	Ve-Ne	Gr-Ve	
⊞	○—○		
⊞		○—○	

HORN BUTTON

	Gi-Rs	Gi-Ro
📣	○—○	

LIGHT SWITCH

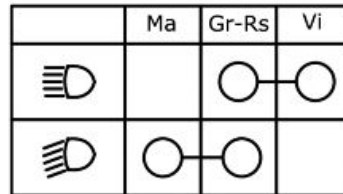

STARTER BUTTON

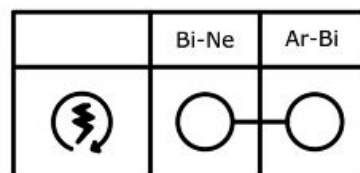

KEY SWITCH

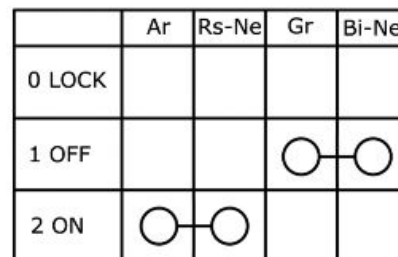

FUEL INJECTOR

Type: 3 holes

Conicity of the nozzle: 20°

Resistance at terminals: 13.7 ÷ 15.2 Ohm

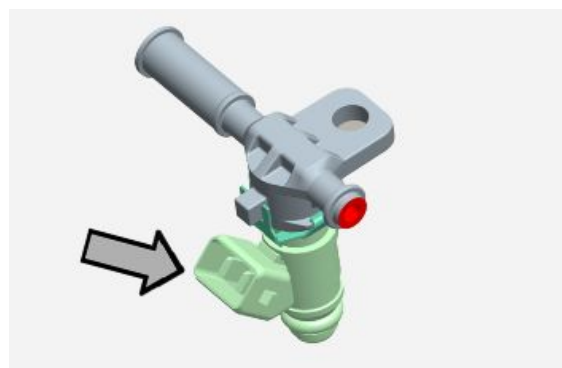

FUEL PUMP UNIT

Mechanical type pressure regulator operating at a pressure of 2.5 BAR

Pump winding resistance: ~ 1.5 Ohm

Input current during regular functioning: 1.4 - 1.8

A

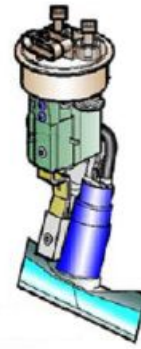

REVOLUTION TIMING SENSOR

Resistance between pins 13 and 15: 100 ÷ 150

Ohm at approx. 20°

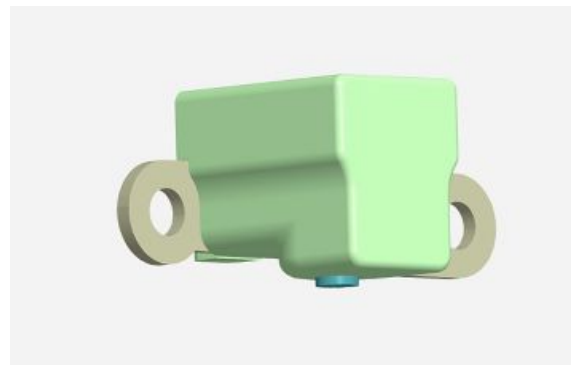

ENGINE TEMPERATURE SENSOR

0° = 5900 Ohm

+10° = 3800 Ohm

+20° = 2500 Ohm

+30° = 1700 Ohm

+80° = 300 Ohm



MINIMUM OIL PRESSURE SENSOR

Normally closed switch

Activation threshold: 0.3 - 0.6 bar

With the engine off: continuity between terminal and ground

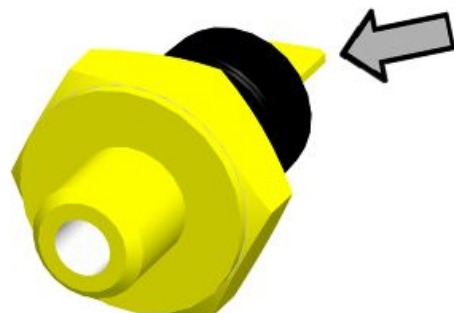

HV COIL

- Resistance of the primary = 0.5 Ohm ± 8%
- Resistance between primary and ground = infinite
- Resistance between primary and HV output = 3.1 KOhm ± 9%
- Presence of battery voltage between pins 22 and 26 of the interface cable harness upon shifting to ON and for 2 sec.

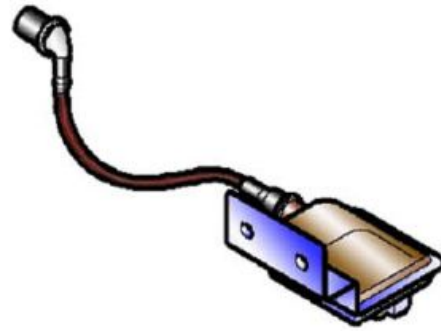

STATOR

- Power: 450 W
- Resistance between terminals: 0.2 ÷ 1 Ohm
- terminal insulation from ground

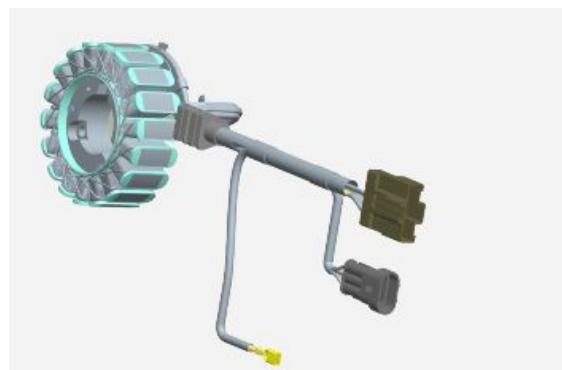

Frame and suspensions

FRAME AND SUSPENSIONS

Specification	Desc./Quantity
Type	Unitised body made of stamped plate
Front suspension	Single arm suspension (cantilever wheel) fitted with a double-acting hydraulic shock absorber with coaxial spring
Front shock absorber axial travel	86.5 mm
Rear suspension	Engine with swinging fork articulated to frame by means of an arm with 2 degrees of freedom Pair of double-acting hydraulic shock absorbers and coaxial springs with preloading adjustment in 4 positions.
Rear shock absorber axial travel	89.5 mm

Brakes

BRAKES

Specification	Desc./Quantity
Front	Ø 220 disc brake and floating calliper with Ø 25 mm twin plungers and hydraulic control (lever on the far right end of the handlebar)
Rear	Ø 220 disc brake and calliper with two Ø 30 mm counteracting plungers and hydraulic control (lever on the far left end of the handlebar)

Wheels and tyres

WHEELS AND TYRES

Specification	Desc./Quantity
Front wheels - light alloy rims	3.00x12
Rear wheels - light alloy rims	3.00x12
Front tyres	120/70-12" Tubeless
Rear tyres	130/70-12" Tubeless

TYRE PRESSURE

Specification	Desc./Quantity
Front tyre pressure (when cold)	1.8 bar
Rear tyre pressure (when cold)	2 bar
Tyre pressure (when cold) with passenger	2.2 bar

N.B.

CHECK AND ADJUST TYRE PRESSURE WITH TYRES AT AMBIENT TEMPERATURE. REGULATE PRESSURE ACCORDING TO THE WEIGHT OF THE RIDER AND ACCESSORIES

Tightening Torques

STEERING ASSEMBLY

Name	Torque in Nm
Upper steering ring nut	35 ÷ 40
Steering lower ring nut	12 ÷ 14
Handlebar fixing screw	45 ÷ 50 (The two screws must be tightened to the prescribed torque after having done so with the rear wheel axle nut. Safety locks: see «Pre-delivery Operations»)
Fixing screws for handlebar control assembly U-bolts	7 ÷ 10

FRAME ASSEMBLY

Name	Torque in Nm
Engine-swinging arm bolt	64 - 72
swinging arm bolt - body shell	76 ÷ 83
Engine and vehicle side swinging arm junction bolt	33 ÷ 41
Bolt of the Silent block support plate	42 ÷ 52
Centre stand bolt	32 ÷ 40
Side stand fixing bolt	35 ÷ 40

FRONT SUSPENSION

Name	Torque in Nm
Screw fixing the shock absorber to the shock absorber - calliper attachment plate	20 ÷ 27
Wheel axle nut	74 ÷ 88
Wheel screw	20 ÷ 25
Screw fixing rear mudguard to steering shock absorber upper clamp	5 ÷ 6.5
	20 ÷ 30

FRONT BRAKE

Name	Torque in Nm
Brake fluid pump-hose fitting	20 ÷ 25
Brake fluid pipe-calliper fitting	19 ÷ 24
Screw fixing calliper to the shock absorber - calliper plate attachment	24 ÷ 27
Disc tightening screw	6 (Apply LOCTITE 242 threadlock, medium strength)
Oil bleed screw	12 - 16
Pad fastening pin	19.6 ÷ 24.5
Brake pump reservoir screws	1.5 ÷ 2
Brake disc screws	8 ÷ 10

REAR SUSPENSION

Name	Torque in Nm
Retainer for left shock absorber to crankcase support plate	20 ÷ 25
Shock absorber lower fitting	40 ÷ 45
Shock absorber upper fitting	20 ÷ 25
Rear wheel axle	104 ÷ 126
Screw fixing wheel to hub	20 ÷ 25
Screws for muffler - shock absorber support arm on engine	20 ÷ 25 (The two screws must be tightened to the prescribed torque after having done so with the rear wheel axle nut. Safety locks: see «Pre-delivery Operations»)
Engine- and vehicle-side swinging arm junction bolt	40 ÷ 45

REAR BRAKE

Name	Torque in Nm
Brake fluid pump-hose fitting	20 ÷ 25
Brake fluid pipe-calliper fitting	20 ÷ 25
Rear disc tightening bolt	11 ÷ 13
Oil bleed screw	12 ÷ 16
Calliper to engine tightening screw	20 ÷ 25
Brake pump reservoir screws	1.5 ÷ 2
Calliper coupling screw	30 ÷ 33

MUFFLER

Name	Torque in Nm
Muffler heat guard fixing screw	4 ÷ 5
Screw for fixing muffler to the support arm	20 ÷ 25
Lambda probe clamp on exhaust manifold	40 ÷ 50
Exhaust manifold-muffler joint clamp	12 ÷ 13
Manifold - muffler diaphragm tightening clamp	16 ÷ 18

LUBRICATION

Name	Torque in Nm
Hub oil drainage plug	15 ÷ 17
Oil filter on crankcase fitting	27 ÷ 33
Engine oil drainage plug/mesh filter	24 ÷ 30
Oil filter	4 ÷ 6
Oil pump cover screws	7 ÷ 9
Screws fixing oil pump to crankcase	5 - 6
Oil pump control crown screw	10 ÷ 14
Oil pump cover plate screws	4 ÷ 6
Oil sump screws	10 ÷ 14
Minimum oil pressure sensor	12 ÷ 14

CYLINDER HEAD

Name	Torque in Nm
Spark plug	12 ÷ 14
Head cover screws	6 ÷ 7
Nuts fixing head to cylinder	7±1 + 10±1 + 270°
Head fixing side screws	11 ÷ 12
Starter ground screw	7 ÷ 8.5
Tappet set screw lock nut	6 ÷ 8
Inlet manifold screws	11 ÷ 13
Timing chain tensioner slider screw	10 ÷ 14
Starter ground support screw	11 ÷ 15
Timing chain tensioner support screw	11 ÷ 13
Timing chain tensioner central screw	5 - 6
Camshaft retention plate screw	4 ÷ 6

TRANSMISSION

Name	Torque in Nm
Belt support roller screw	11 ÷ 13
Clutch unit nut on driven pulley	45 ÷ 50

Name	Torque in Nm
Drive pulley nut	75 ÷ 83
Transmission cover screws	11 ÷ 13
Driven pulley shaft nut	54 ÷ 60
Rear hub cap screws	24 ÷ 27

FLYWHEEL

Name	Torque in Nm
Flywheel cover screw	11 ÷ 13
Stator assembly screws	3 - 4 (Apply LOCTITE 242 medium-strength threadlock)
Flywheel nut	94 ÷ 102
Pick-Up clamping screws	3 ÷ 4
Screw fixing freewheel to flywheel	13 ÷ 15

CRANKCASE AND CRANKSHAFT

Name	Torque in Nm
Internal engine crankcase bulkhead (transmission-side half shaft) screws	4 ÷ 6
Engine-crankcase coupling screws	11 ÷ 13
Starter motor screws	11 ÷ 13
Crankcase timing cover screws	3.5 - 4.5 (Apply LOCTITE 242 medium-strength threadlock)

COOLING

Name	Torque in Nm
Water pump rotor cover	3 ÷ 4
Thermostat cover screws	3 ÷ 4
Bleed screw	3

Overhaul data

Assembly clearances

Cylinder - piston assy.

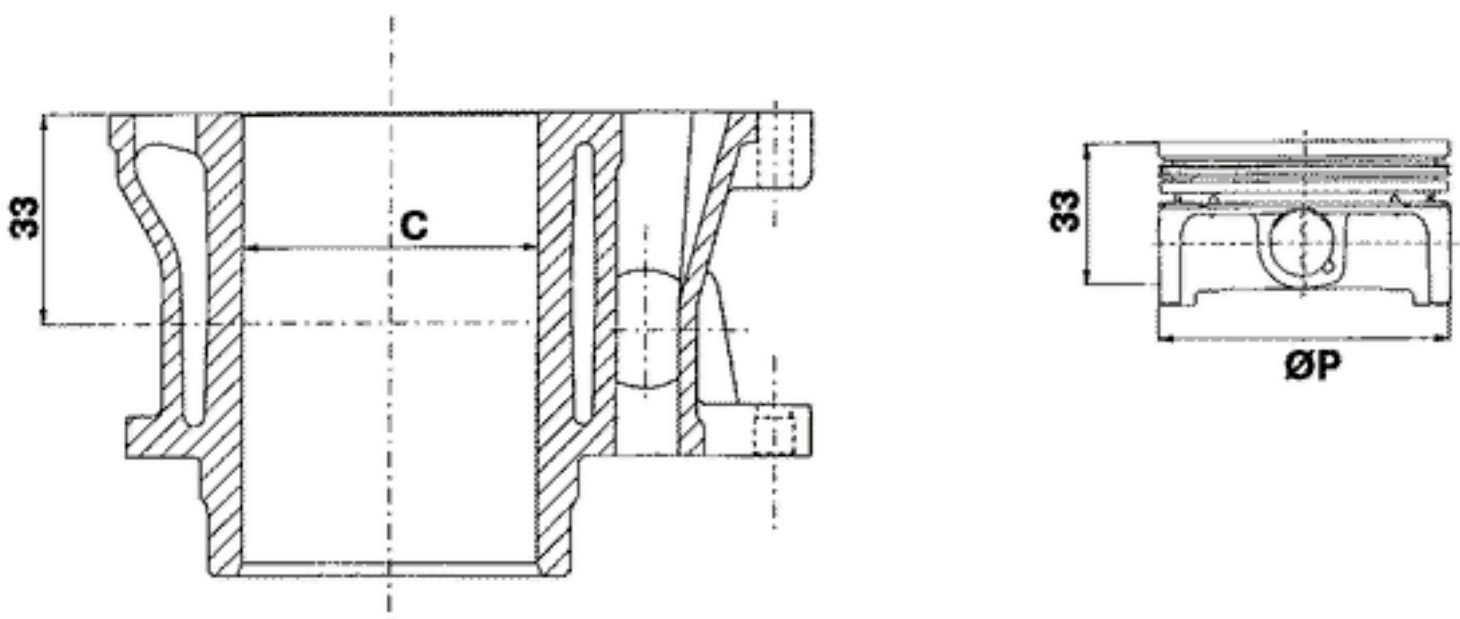

CYLINDER - PISTON

Specification	Desc./Quantity
Plunger diameter	74.967 +0.014 -0.014 mm
Cylinder diameter	75 +0.038 +0.01 mm

COUPLING CATEGORIES

Name	Initials	Cylinder	Piston	Play on fitting
cylinder-piston	M	75.01 ÷ 75.017	74.953 ÷ 74.960	0.050 ÷ 0.064
cylinder-piston	N	75.017 ÷ 75.024	74.960 ÷ 74.967	0.050 ÷ 0.064
cylinder-piston	O	75.024 ÷ 75.031	74.967 ÷ 74.974	0.050 ÷ 0.064
cylinder-piston	P	75.031 ÷ 75.038	74.974 ÷ 74.981	0.050 ÷ 0.064

N.B.

THE PISTON MUST BE INSTALLED WITH THE ARROW FACING TOWARDS THE EXHAUST SIDE, THE PISTON RINGS MUST BE INSTALLED WITH THE WORD «TOP» OR THE STAMPED MARK FACING UPWARDS.

- Measure the outside diameter of the gudgeon pin.

Characteristic
Pin outside diameter
 16 +0 -0.004 mm

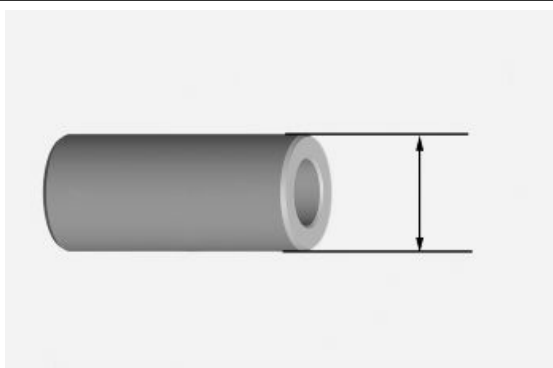

- Measure the diameter of the bearings on the piston.

Characteristic
Standard diameter
 16 +0.006 +0.001 mm

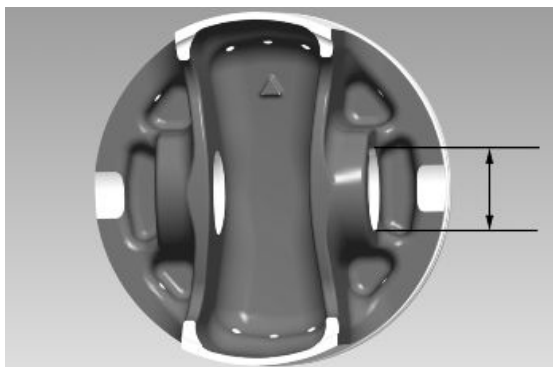

- Calculate the piston pin coupling clearance.

N.B.

THE PIN HOUSINGS HAVE 2 LUBRICATION CHANNELS. FOR THIS REASON, MEASUREMENT MUST BE MADE ACCORDING TO THE PISTON AXIS.

Characteristic
Standard clearance:
 0.001 ÷ 0.010 mm

- Carefully clean the sealing ring housings.
- Measure the coupling clearance between the sealing rings and the grooves using suitable sensors, as shown in the diagram.
- If the clearance is greater than that indicated in the table, replace the piston.

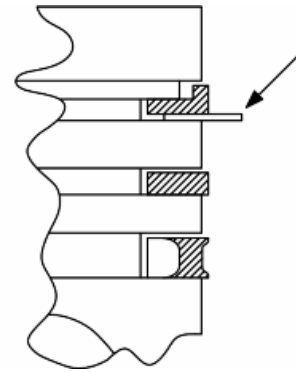

N.B.

MEASURE THE CLEARANCE BY INSERTING THE BLADE OF THE FEELER THICKNESS GAUGE FROM THE SECOND SEAL SIDE.

Fitting clearance

Top piston ring - standard coupling clearance 0.015 - 0.06 mm **Top piston ring - maximum clearance allowed after use** 0.07 mm **Middle piston ring - standard coupling clearance** 0.015 - 0.06 mm **Middle piston ring - maximum clearance allowed after use** 0.07 mm **oil scraper ring - standard coupling clearance** 0.015 - 0.06 mm **oil scraper ring - maximum clearance allowed after use** 0.07 mm

- Check that the head coupling surface is not worn or misshapen.
- Pistons and cylinders are classified according to diameter. The coupling must be made with those of the same type (M-M, N-N, O-O, P-P).



Characteristic

Maximum allowable run-out:

0.05 mm

Crankcase - crankshaft - connecting rod

CRANKSHAFT

Titolo	Durata/Valore	Testo Breve (< 4000 car.)	Indirizzo Immagine
Crankshaft		Crankshaft to crankcase axial clearance	

Crankshaft to crankcase axial clearance

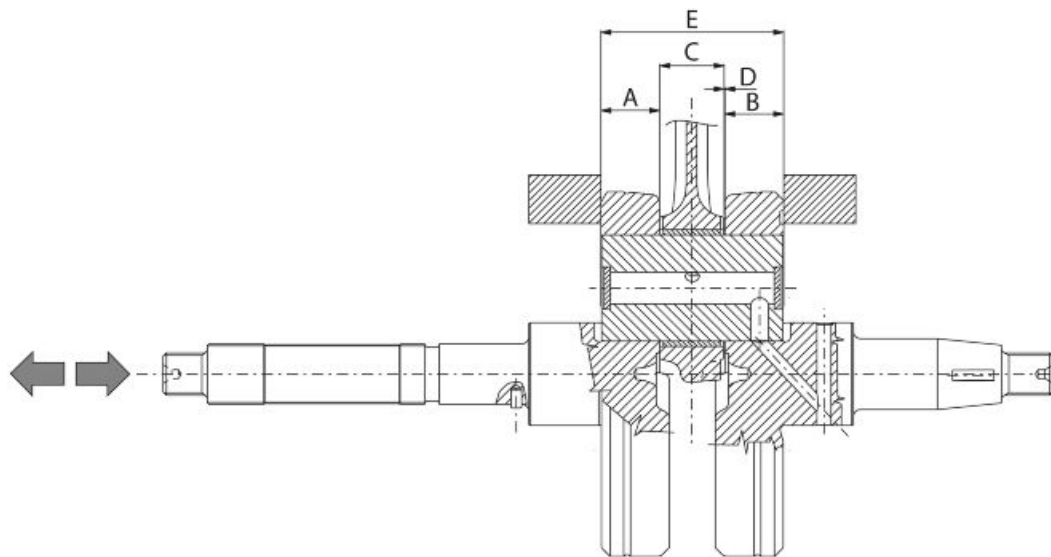

AXIAL CLEARANCE BETWEEN CRANKSHAFT AND CONNECTING ROD

Name	Description	Dimensions	Initials	Quantity
Half-shaft, transmission side		16.6 +0-0.05	A	D = 0.20 - 0.50
Flywheel-side half-shaft		16.6 +0-0.05	B	D = 0.20 - 0.50
Connecting rod		18 -0.10 -0.15	C	D = 0.20 - 0.50
Spacer tool		51.4 +0.05	E	D = 0.20 - 0.50

Diameter of crankshaft bearings.

Measure the bearings on both axes x-y.

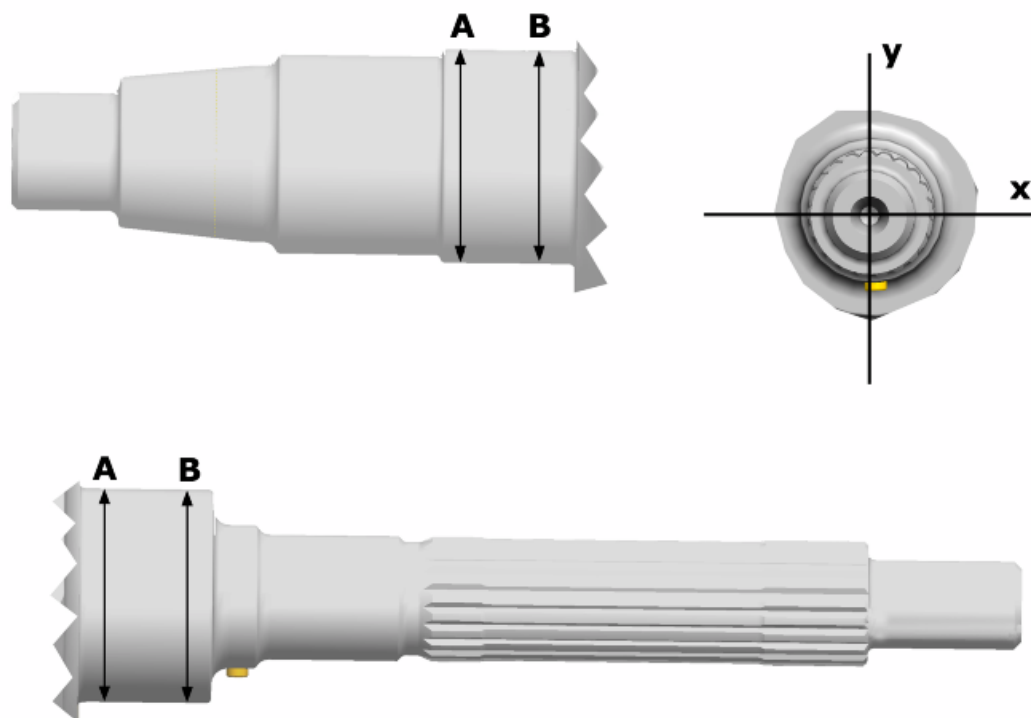

CRANKSHAFT

Specification	Desc./Quantity
Crankshaft bearings: Standard diameter: Cat. 1	28.998 ÷ 29.004 mm
Crankshaft bearings: Standard diameter: Cat. 2	29.004 ÷ 29.010 mm

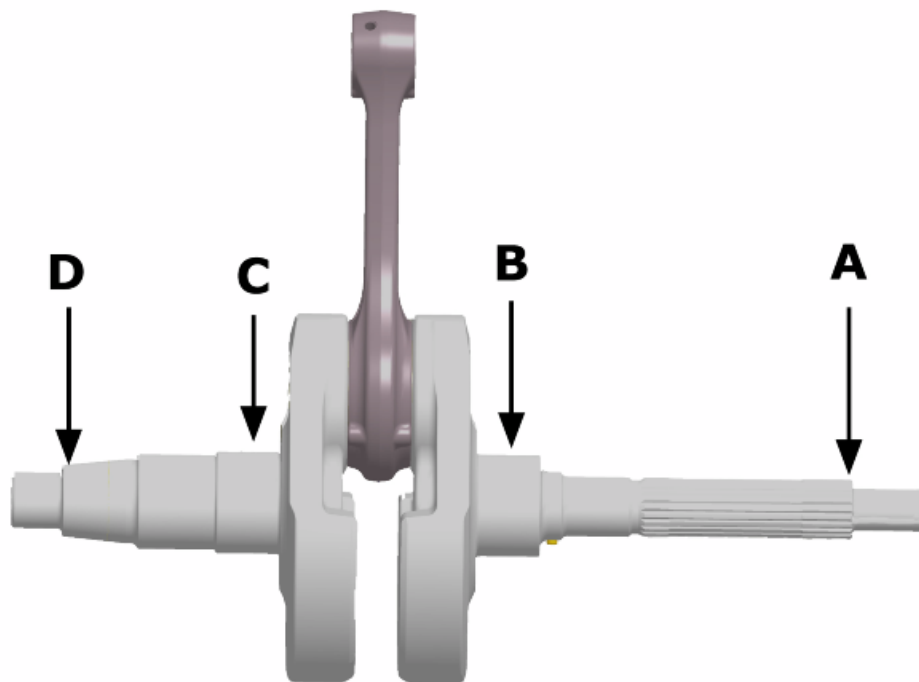

MAX. ADMISSIBLE DISPLACEMENT

Specification	Desc./Quantity
A =	0.15 mm
B =	0.010 mm
C =	0.010 mm
D =	0.10 mm

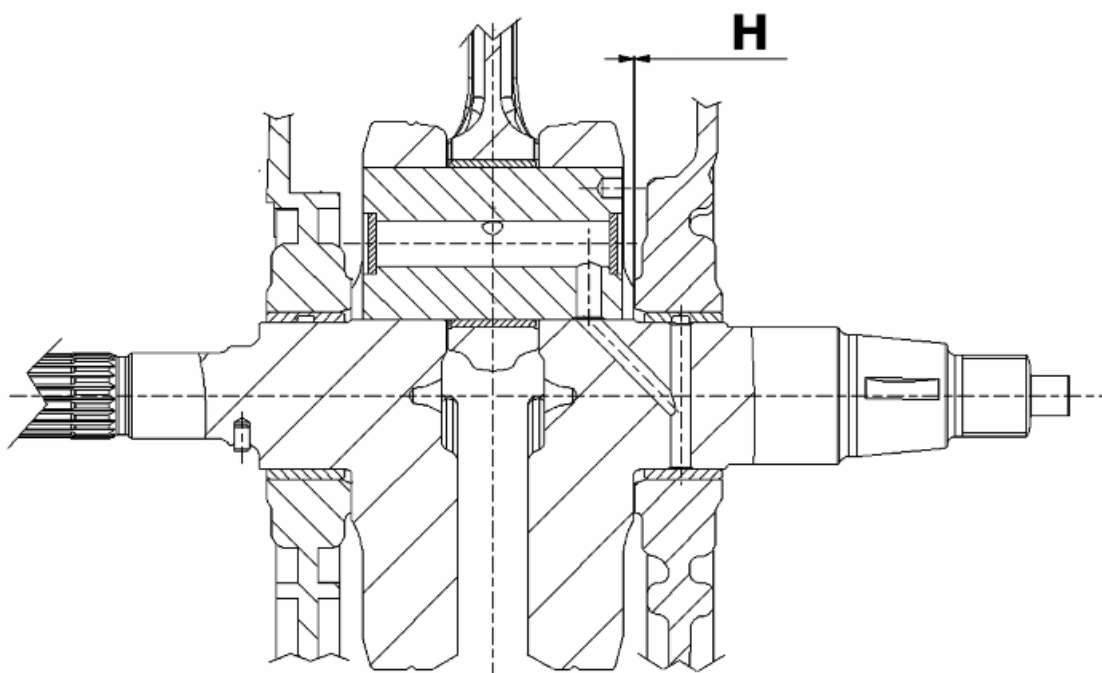

Characteristic**Crankshaft-crankcase axial clearance (H)**

0.15 ÷ 0.43 mm

- Using a bore gauge, measure the connecting rod small end diameter.

N.B.

IF THE CONNECTING ROD SMALL END DIAMETER EXCEEDS THE STANDARD DIAMETER, EXHIBITS WEAR OR OVERHEATING, PROCEED TO REPLACE THE CRANKSHAFT AS DESCRIBED IN THE CRANKCASE AND CRANKSHAFT CHAPTER.

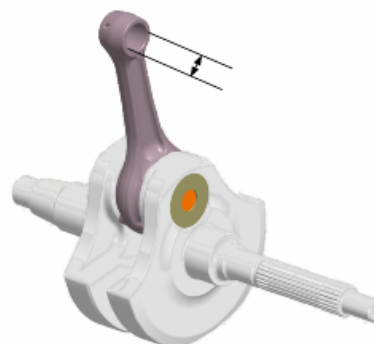
**Characteristic****Standard diameter**

16 +0.025 +0.015 mm

- To obtain a good bushing lubrication it is necessary to have both an optimal lubricating pressure and a good oil flow rate; the bushings must be correctly positioned so as not to obstruct the oil supply channels.
- The main bushings are comprised of two half-bearings, one with holes and channels for lubrication whereas the other is solid.
- The solid half-bearing is intended to stand the thrusts caused by combustion, and for this reason it is arranged opposite the cylinder.
- To prevent obstructions in the oil feeding channels, the matching surface of the two half-bearings must be perfectly perpendicular to the cylinder axis, as shown in the figure.
- The oil feeding channel section is also affected by the bushings driving depth compared with the crankshaft axial clearance of the limiting surface.
- Check the inside diameter of the main bushings in the three directions indicated in the diagram.
- Repeat the measurements for the other bushing half. see diagram.
- There are three crankcase versions: with BLUE bushings, with YELLOW bushings and with GREEN bushings.
- There is only one type of main bushing housing hole in the crankcase. The standard bushing diameter after driving is variable on the basis of a coupling selection.
- The bushing housings in the crankcase are classified into 2 categories - Cat. 1 and Cat. 2 - just like those for the crankshaft.
- The main bushings are available in three thickness categories, identified by colour markings, as shown in the table below.

BUSHINGS

TYPE	IDENTIFICATION	CRANKSHAFT HALF-BEARING
B	BLUE	1.973 ÷ 1.976
C	YELLOW	1.976 ÷ 1.979
E	GREEN	1.979 ÷ 1.982

COUPLINGS

BUSHING CATEGORY	CRANKCASE HALVES CATEGORY	BUSHING INSIDE DIAMETER AFTER FITTING
B	2	29.024 ÷ 29.054
C	1	29.024 ÷ 29.054
	2	29.018 ÷ 29.048
E	1	29.018 ÷ 29.048

Combine the shaft with two category 1 crankwebs with the category 1 crankcase (or cat. 2 with cat. 2). Furthermore a spare crankcase cannot be matched with a crankshaft with mixed categories. The spare crankshaft has half-shafts of the same category.

CATEGORIES

CRANKCASE HALVES	ENGINE HALF-SHAFT	BUSHING
Cat. 1	Cat. 1	E
Cat. 2	Cat. 2	B
Cat. 1	Cat. 2	C
Cat. 2	Cat. 1	C

N.B.

DO NOT TAKE THE MEASUREMENT ON THE TWO HALF-SHELL COUPLING SURFACE SINCE THE ENDS ARE RELIEVED TO ALLOW BENDING DURING THE DRIVING OPERATION.

N.B.

CRANKCASES FOR REPLACEMENTS ARE SELECTED WITH CRANKCASE HALVES OF THE SAME CATEGORY AND ARE FITTED WITH CATEGORY C BUSHINGS (YELLOW)

Characteristic

Crankshaft-bushing maximum clearance admitted:

0.08 mm

Diameter of crankcase without bushing

CAT. 1: 32.959 ÷ 32.965 mm

CAT. 2: 32.953 ÷ 32.959 mm

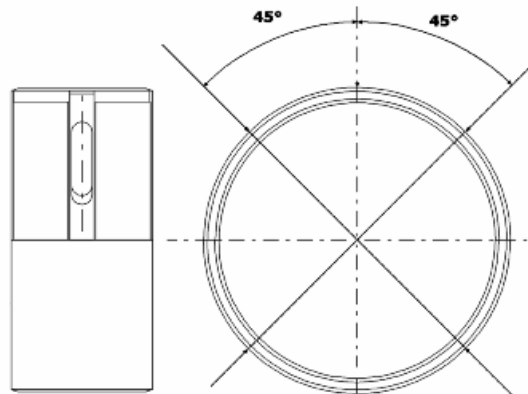

Cylinder Head

Before performing head service operations, thoroughly clean all coupling surfaces. Note the position of the springs and the valves so as not to change the original position during refitting

- Using a trued bar and a feeler thickness gauge check that the cylinder head surface is not worn or distorted.

Characteristic

Maximum allowable run-out:

0.1 mm



- In case of irregularities, replace the head.

- Check the sealing surfaces for the intake and exhaust manifold.
- Check that the bearings of the camshaft and the rocker pins exhibit no wear.
- Check that the head cover surface is not worn.
- Check that the coolant sealing pad exhibits no oxidation.

- Insert the valves into the cylinder head.
- Alternatively check the intake and exhaust valves.
- The test is carried out by filling the manifold with petrol and checking that the head does not ooze through the valves when these are just pressed with the fingers.

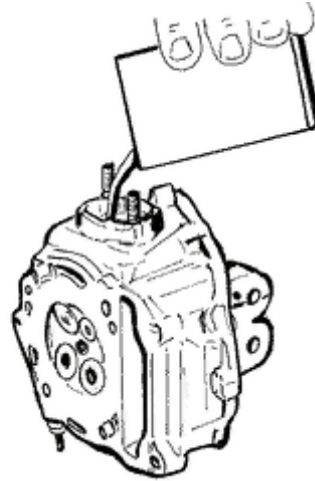

Measure the camshaft bearing seats and rocking lever support pins with a bore meter

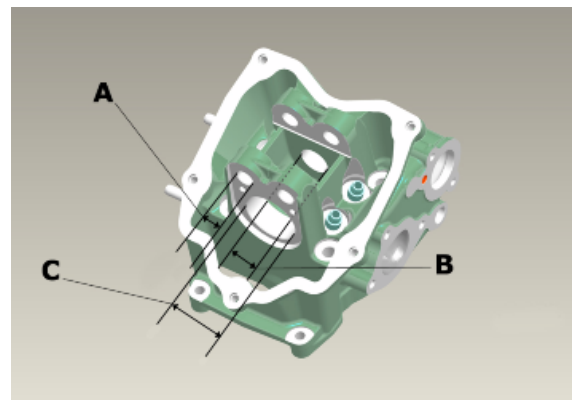

HEAD BEARINGS

Specification	Desc./Quantity
bearing «A»	Ø 12.000 - 12.018 mm
bearing «B»	Ø 20.000 ÷ 20.021 mm
bearing «C»	Ø 37.000 - 37.025 mm

Measure the unloaded spring length

Characteristic
Standard length

40.2 mm

Allowable limit after use:

38.2 mm

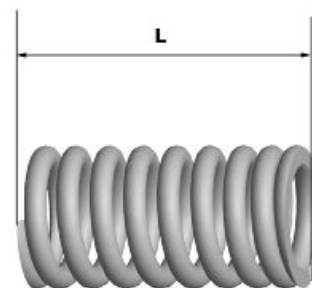

- Clean the valve seats of any carbon residues.
- Using the Prussian blue, check the width of the impression on the valve seat "V".

Characteristic

Standard value:

1 - 1.3 mm

Admissible limit:

1.6 mm

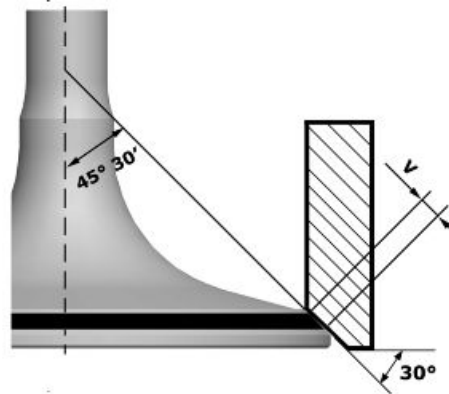

- If the impression width on the valve seat is larger than the prescribed limits, true the seats with a 45° mill and then grind.
- In case of excessive wear or damages, replace the head.

STANDARD VALVE LENGTH

Specification	Desc./Quantity
Valve check standard length	Inlet: 94.6 mm
Valve check standard length	Outlet: 94.4 mm

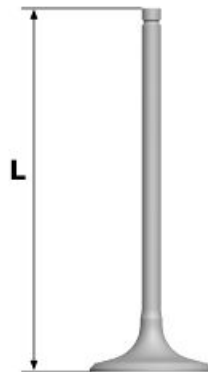

- Measure the diameter of the valve stems in the three positions indicated in the diagram.

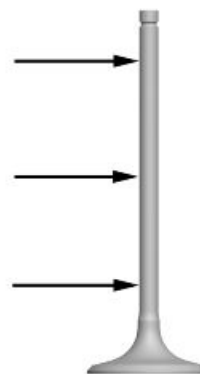

STANDARD DIAMETER

Specification	Desc./Quantity
Inlet:	4.987 - 4.972 mm
Outlet:	4.975 - 4.960 mm

MINIMUM ADMISSIBLE DIAMETER

Specification	Desc./Quantity
Inlet:	4.96 mm
Outlet:	4.945 mm

- Calculate the clearance between valve and valve guide.

- Check the deviation of the valve stem by resting it on a "V" shaped abutment and measuring the extent of the deformation with a comparator.

Characteristic

Limit values admitted:

0.1 mm

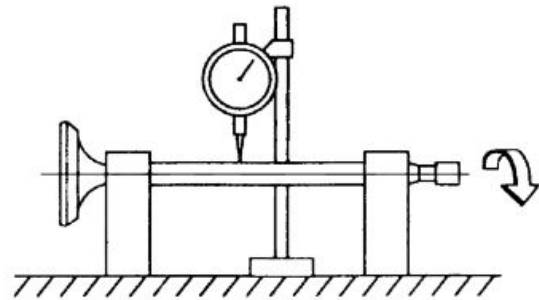

- Check the concentricity of the valve head by arranging a comparator at right angle relative to the valve head and rotate it on a "V" shaped abutment.

Characteristic

Admissible limit:

0.03 mm

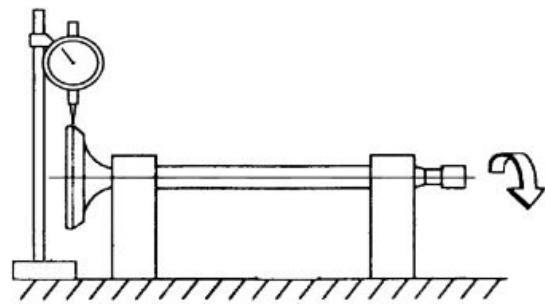

Measure the valve guide.

Characteristic

Valve guide:

5 +0.012 mm

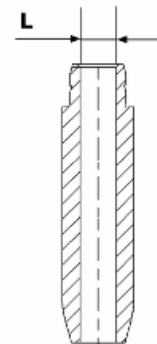

- After measuring the valve guide diameter and the valve stem diameter, check the clearance between guide and stem.

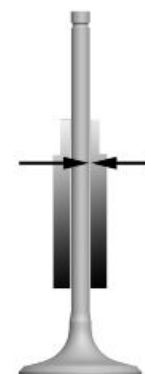

INLET

Specification	Desc./Quantity
Standard clearance:	0.013 - 0.04 mm
Admissible limit:	0.08 mm

OUTLET

Specification	Desc./Quantity
Standard clearance:	0.025 ÷ 0.052 mm
Admissible limit:	0.09 mm

- Check that there are no signs of wear on the surface of contact with the articulated register terminal.

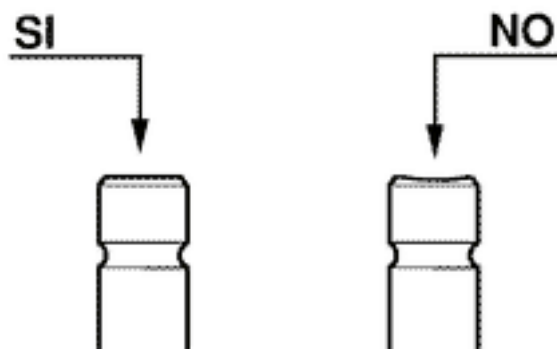

- If the checks above give no failures, you can use the same valves. To obtain better sealing performance, grind the valve seats. Grind the valves gently with a fine-grained lapping compound. During the grinding, keep the cylinder head with the valve axes in a horizontal position. This will prevent the lapping compound residues from penetrating between the valve stem and the guide (see figure).



CAUTION

TO AVOID SCORING THE FAYING SURFACE, DO NOT KEEP ROTATING THE VALVE WHEN NO LAPPING COMPOUND IS LEFT. CAREFULLY WASH THE CYLINDER HEAD AND THE VALVES WITH A SUITABLE PRODUCT FOR THE TYPE OF LAPPING COMPOUND BEING USED.

CAUTION

DO NOT REVERSE THE FITTING POSITIONS OF THE VALVES (RIGHT - LEFT).

- Check that the camshaft bearings exhibit no scores or abnormal wear.
- Using a micrometer, measure the camshaft bearings.

STANDARD DIAMETER

Specification	Desc./Quantity
Cam shaft check: Standard diameter	Bearing A Ø: 36.95 ÷ 36.975 mm
Cam shaft check: Standard diameter	Bearing B diameter: 19.959 ÷ 19.98 mm

MINIMUM DIAMETER PERMITTED

Specification	Desc./Quantity
Cam shaft check: Minimum admissible diameter	Bearing A Ø: 36.94 mm

Specification	Desc./Quantity
Cam shaft check: Minimum admissible diameter	Bearing B diameter: 19.950 mm

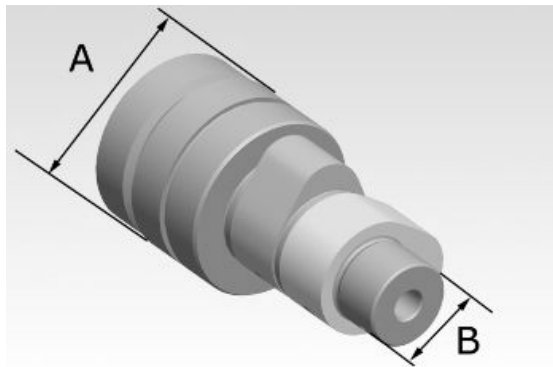

-Using a gauge, measure the cam height.

STANDARD HEIGHT

Specification	Desc./Quantity
Cam shaft check: Standard height	Inlet: 30.285 mm
Cam shaft check: Standard height	Outlet: 29.209 mm

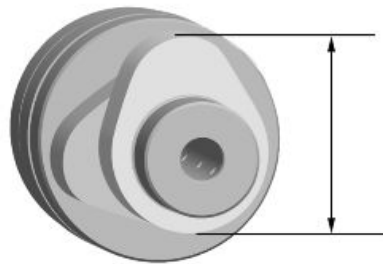

Check the axial clearance of the camshaft

CAMSHAFT AXIAL CLEARANCE

Specification	Desc./Quantity
Cam shaft check: Standard axial clearance:	0.11 - 0.41 mm
Cam shaft check: Maximum admissible axial clearance	0.42 mm

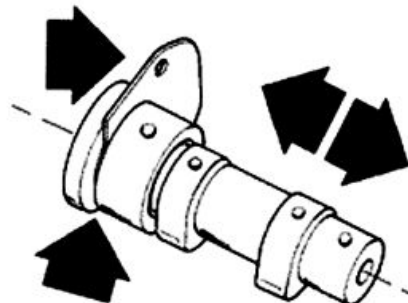

- Measure the outside diameter of the rocking lever pins
- Check the rocking lever pins do not show signs of wear or scoring.
- Measure the inside diameter of each rocking lever.

Check there are no signs of wear on the pad from contact with the cam and on the jointed adjustment plate.

ROCKING LEVERS AND PIN DIAMETER:

Specification	Desc./Quantity
Internal rocker arm diameter: Standard diameter	Diameter 12.000 - 12.011 mm
Rocking lever pin diameter: Standard diameter	Diameter 11.977 - 11.985 mm



Slot packing system

Characteristic

Compression ratio

10.5 ÷ 11.5 : 1

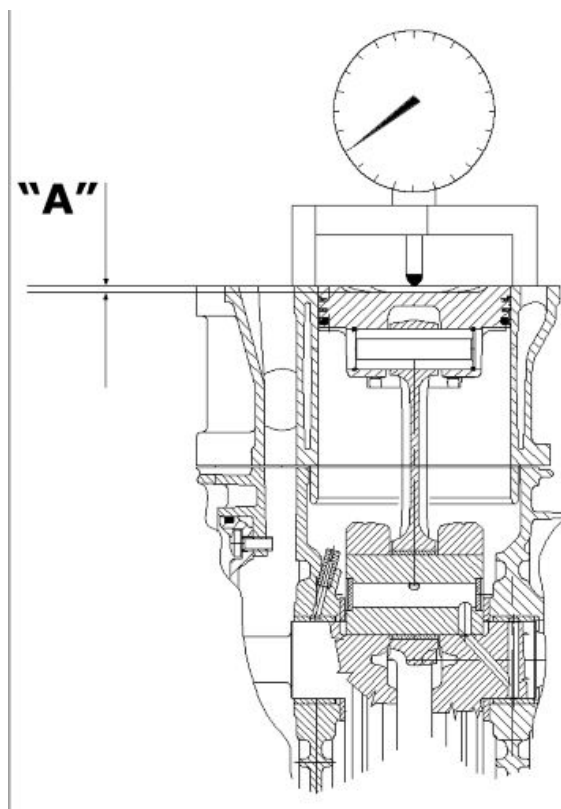

Measurement "A" to be taken is a value of piston re-entry, it indicates by how much the plane formed by the piston crown falls below the plane formed by the top of the cylinder. The further the piston falls

inside the cylinder, the less the base gasket to be applied (to recover the compression ratio) and vice versa.

N.B.

MEASUREMENT "A" MUST BE TAKEN WITHOUT ANY GASKET FITTED BETWEEN THE CRANK-CASE AND CYLINDER AND AFTER RESETTING THE GAUGE, EQUIPPED WITH A SUPPORT, ON A GROUND PLANE

ENGINE 300 SHIMMING

Name	Measure A	Thickness
shimming	3.70 - 3.60	0.4 ± 0.05
shimming	3.60 - 3.40	0.6 ± 0.05
shimming	3.40 - 3.30	0.8 ± 0.05

Products

RECOMMENDED PRODUCTS TABLE







Product	Description	Specifications
AGIP ROTRA 80W-90	Rear hub oil	SAE 80W/90 Oil that exceeds the requirements of API GL3 specifications
AGIP CITY HI TEC 4T	Oil to lubricate flexible transmissions (throttle control)	Oil for 4-stroke engines
AGIP FILTER OIL	Oil for air filter sponge	Mineral oil with specific additives for increased adhesiveness
AGIP GP 330	Grease for brake levers, throttle	White calcium complex soap-based spray grease with NLGI 2; ISO-L-XBCIB2
AGIP CITY HI TEC 4T	Engine oil	SAE 5W-40, API SL, ACEA A3, JASO MA Synthetic oil
AGIP BRAKE 4	Brake fluid	FMVSS DOT 4 Synthetic fluid
AGIP PERMANENT SPEZIAL	coolant	Monoethylene glycol-based antifreeze fluid, CUNA NC 956-16
AGIP GREASE PV2	Grease for the steering bearings, pin seats and swinging arm	Soap-based lithium and zinc oxide grease containing NLGI 2; ISO-L-XBCIB2 of the swinging arm

INDEX OF TOPICS

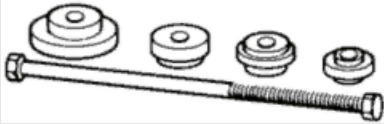

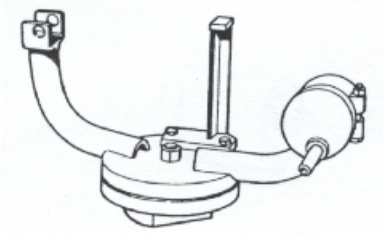

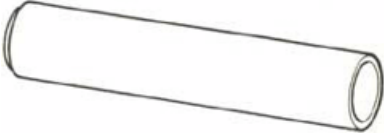

TOOLING

TOOL

ATTREZZATURA SPECIFICA

Stores code	Description	
001330Y	Tool for fitting steering seats	
001467Y017	Bell for bearings, OD 39 mm	
001467Y014	Pliers to extract ø 15-mm bearings	
005095Y	Engine support	
002465Y	Pliers for circlips	
006029Y	Punch for fitting fifth wheel seat on steering tube	
020004Y	Punch for removing fifth wheels from headstock	

Stores code	Description	
020021Y	Front suspension service tool	
020036Y	Punch	
020038Y	Punch	
020055Y	Wrench for steering tube ring nut	
020074Y	Support base for checking crankshaft alignment	
020150Y	Air heater support	

Stores code	Description	
020151Y	Air heater	 A handheld air heater with a black body and a silver nozzle, connected to a black power cord.
020193Y	Oil pressure gauge	 An oil pressure gauge with a circular dial, a black hose, and a black push-button.
020262Y	Crankcase splitting strip	 A metal plate with a central vertical rod and a handle, used for splitting the crankcase.
020263Y	Sheath for driven pulley fitting	 A cylindrical metal sheath with a flange at the top.
020306Y	Punch for assembling valve seal rings	 A long, thin metal punch with a handle.
020329Y	MityVac vacuum-operated pump	 A complex mechanical assembly with various components, including a pump and a vacuum chamber.

Stores code

Description

020330Y

Stroboscopic light to check timing



020331Y

Digital multimeter



020332Y

Digital rev counter



020648Y

Single battery charger



Stores code	Description
-------------	-------------

020335Y	Magnetic support for dial gauge
---------	---------------------------------



020357Y	32 x 35 mm adaptor
020359Y	42x47-mm adaptor



020360Y	Adaptor 52 x 55 mm
---------	--------------------

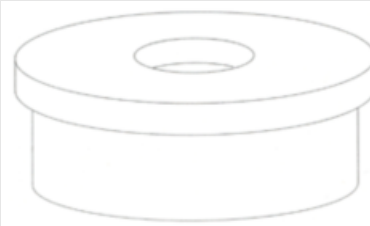

020363Y	20 mm guide
---------	-------------



020364Y	25-mm guide
---------	-------------



Stores code	Description
-------------	-------------

020365Y

22 mm guide



020375Y

Adaptor 28 x 30 mm



020376Y

Adaptor handle



020382Y

Valve cotters equipped with part 012 removal tool



020382Y011



adapter for valve removal tool







020393Y





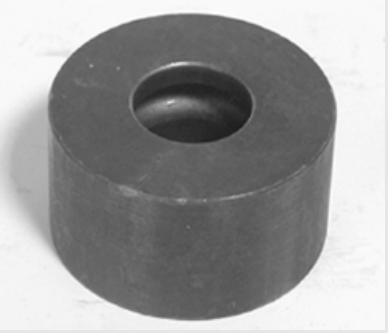

Piston fitting band







Stores code	Description	
020412Y	15 mm guide	
020423Y	driven pulley lock wrench	
020424Y	Driven pulley roller casing fitting punch	
020426Y	Piston fitting fork	
020431Y	Valve oil seal extractor	
020434Y	Oil pressure control fitting	

Stores code	Description	
020441Y	26 x 28 mm adaptor	
020444Y	Tool for fitting/ removing the driven pulley clutch	
020456Y	Ø 24 mm adaptor	
020477Y	Adaptor 37 mm	
020483Y	30 mm guide	
020489Y	Hub cover support stud bolt set	

Stores code	Description	
020428Y	Piston position check support	
020460Y	Scooter diagnosis and tester	
020621Y	HV cable extraction adaptor	
020481Y	Control unit interface wiring	
001467Y035	Belle for OD 47-mm bearings	
020626Y	Driving pulley lock wrench	

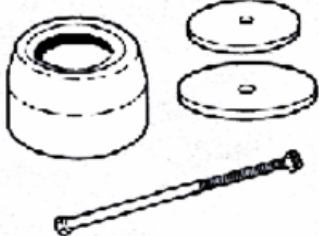
Stores code	Description	
001467Y013	Pliers to extract \varnothing 15-mm bearings	
020627Y	Flywheel lock wrench	
020467Y	Flywheel extractor	
020454Y	Tool for fitting piston pin stops (200 - 250)	
020622Y	Transmission-side oil guard punch	
020480Y	Petrol pressure check set	

Stores code	Description	
020244Y	15 mm diameter punch	
020115Y	Ø 18 punch	
020271Y	Tool for removing-fitting silent bloc	
020469Y	Reprogramming kit for scooter diagnosis tester	

INDEX OF TOPICS

MAINTENANCE

MAIN

Maintenance chart

SCHEDULED MAINTENANCE TABLE

I: CHECK AND CLEAN, ADJUST, LUBRICATE OR REPLACE IF NECESSARY.

C: CLEAN, R: REPLACE, A: ADJUST, L: LUBRICATE

** Replace every 2 years*

km x 1,000	1	5	10	15	20	25	30	35	40	45	50	55	60
Safety locks	I		I				I				I		I
Spark plug			R		R		R		R		R		R
Driving belt				R			R			R			R
Throttle control	A		A		A		A		A		A		A
Air filter			C		C		C		C		C		C
Belt compartment air filter			I		I		I		I		I		I
Oil filter	R		R		R		R		R		R		R
Valve clearance					A				A				A
Electrical system and battery	I		I		I		I		I		I		I
Brake fluid *	I		I		I		I		I		I		I
Coolant *	I		I		I		I		I		I		I
Engine oil	R	I	R	I	R	I	R	I	R	I	R	I	R
Hub oil	R		I		R		I		R		I		R
Brake pads	I	I	I	I	I	I	I	I	I	I	I	I	I
Sliding blocks / variable speed rollers			R		R		R		R		R		R
Tyre pressure and wear	I		I		I		I		I		I		I
Vehicle road test	I		I		I		I		I		I		I
Suspensions			I		I		I		I		I		I
Steering	A		A		A		A		A		A		A

TABELLA MANUTENZIONE TIME

Km x 1000	1	5	10	15	20	25	30	35	40	45	50	55	60
Tempo Operazione	60'	10'	100'	45'	150'	10'	140'	10'	150'	45'	100'	10'	190'

Checking the spark advance

The ignition advance is determined electronically on the basis of parameters known by the control unit. For this reason it is not possible to interpret the reference values based on the engine rpm.

The ignition advance value is detectable at any time using the diagnostic tester. It is possible to check whether the ignition advance determined by the injection system matches the value actually activated on the engine, by means of the stroboscopic light.

Proceed as follows:

- Remove the spark plug.
- Remove the plastic cover on the flywheel cover shown in the photograph.



- Remove the transmission compartment air intake cover shown in the photograph.
- Rotate the driving pulley fan using a screwdriver until the reference marks between the flywheel and flywheel cover coincide as shown in the photograph.
- Bring the reference mark onto the transmission side between the fan and the transmission cover as shown in the photograph.
- Refit the spark plug.
- Refit the plastic cap on the flywheel cover.
- Adjust the spark gap to the contact position (no reference mark visible) and install it on engine between the spark plug and spark plug cap
- Connect the induction clamp on the spark gap cable respecting the proper polarity (the arrow on the clamp must be pointing at the spark plug).
- Connect the diagnostic tester.
- Start the engine.
- Select the «parameter» function in this menu.
- Select the stroboscopic light command in the traditional four-stroke engine position (1 spark 2 revs).
- Check that the real values of rpm and ignition advance match those measured using the diagnostic tester.

If the values do not correspond, check:

- distribution timing
- rpm-timing sensor
- injection control unit

Specific tooling

020460Y Scooter diagnosis and tester

020330Y Stroboscopic light to check timing

020621Y HV cable extraction adaptor

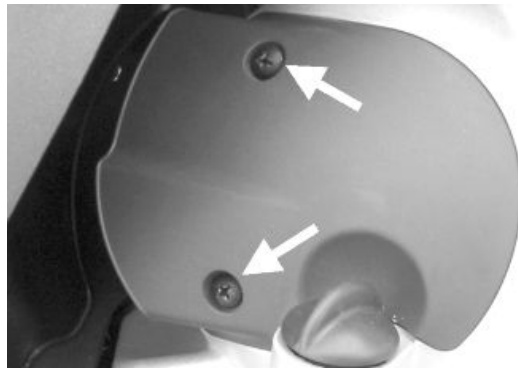



Spark plug

- Rest the scooter on its stand
- Open the saddle and take out the helmet compartment
- Disconnect the spark plug HV wire cap;
- Unscrew the spark plug using the wrench supplied;
- Check the conditions of the spark plug, make sure the insulation is intact, that the electrodes are not excessively worn or sooty, the conditions of the washer, and measure the distance between the electrodes using the appropriate feeler thickness gauge.
- Adjust the distance, if necessary, by bending the side electrode very carefully. In case of anomaly (as described before), replace the spark plug with another of the recommended type;
- Fit the spark plug with the correct inclination and manually screw it all the way down, then use the special spanner to tighten it.
- Insert the cap onto the spark plug and proceed with the reassembly operations.

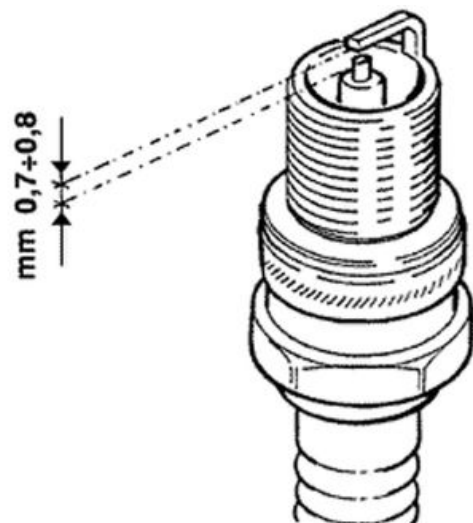

CAUTION

THE SPARK PLUG MUST BE REMOVED WHEN THE MOTOR IS COLD. THE SPARK PLUG MUST BE REPLACED EVERY 20,000 KM. THE USE OF NON CONFORMING ELECTRONIC IGNITION CONTROL UNITS OR SPARK PLUGS OTHER THAN THOSE PRESCRIBED CAN SERIOUSLY DAMAGE THE ENGINE.

Characteristic

Electrode gap

0.7-0.8 mm

Electric characteristic

Spark plug

NGK CR8EKB

Locking torques (N*m)

Spark plug 12 ÷ 14

Hub oil

Check

- Park the vehicle on its centre stand on flat ground;
- Remove the oil dipstick «A», dry it with a clean cloth and put it back into its hole **tightening it completely**;

Remove the dipstick and check that the oil level is slightly over the second notch starting from the lower end; if the level is under the MAX. mark, it needs to be filled with the right amount of hub oil.

- Screw up the oil dipstick again and make sure it is locked properly into place.

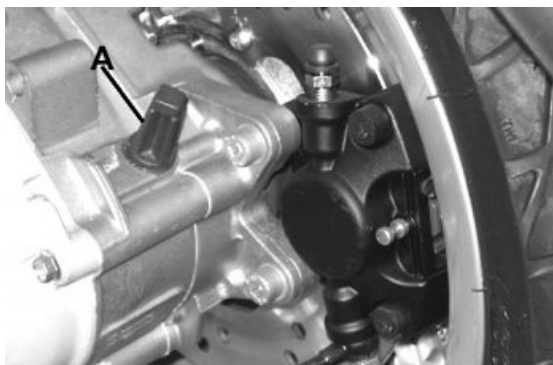
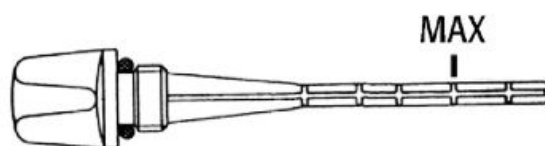

Replacement

- Remove the oil filler cap «A».
- Unscrew the oil drainage cap "B" and drain out all the oil.
- Screw in the drainage cap again and fill the hub with the prescribed oil.

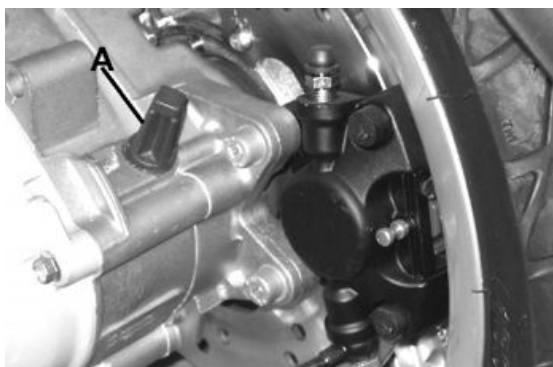

Recommended products

AGIP ROTRA 80W-90 Rear hub oil

SAE 80W/90 Oil that exceeds the requirements of API GL3 specifications

Characteristic

Rear hub oil

Capacity approximately 250 cc

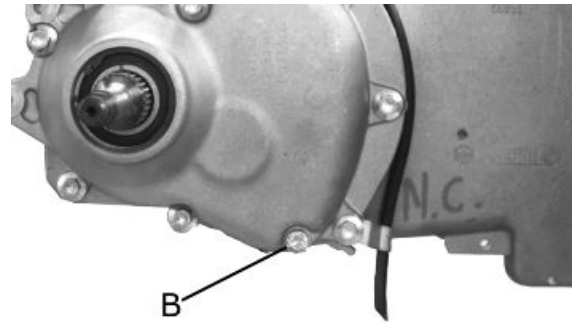
Locking torques (N*m)Hub oil drainage screw $15 \div 17$ Nm**Air filter**

Proceed as follows:

1. unscrew the fixing screw «A».
2. unscrew the nut «B» under the body.
3. remove the left side fairing.
4. remove the helmet compartment;
5. unscrew the fixing screws «C» that can be reached once the helmet compartment has been removed;
6. Unscrew the screws «D» and remove the air filter cover.

Remove the filtering element and clean it with water and shampoo; then dry it with a clean cloth and short blasts of compressed air. Finally, immerse it in a mixture of 50% oil of the recommended type and 50% petrol. Then gently squeeze the filter element between your hands, allow it to drip and then refit it. Oil or water deposits in the filter housing can be cleaned off by removing the two rubber caps «E».

CAUTION

IF THE VEHICLE IS USED ON DUSTY ROADS, IT IS NECESSARY TO SERVICE THE AIR FILTER MORE OFTEN TO AVOID DAMAGING THE ENGINE.

Recommended products**AGIP FILTER OIL Oil for air filter sponge**

Mineral oil with specific additives for increased adhesiveness

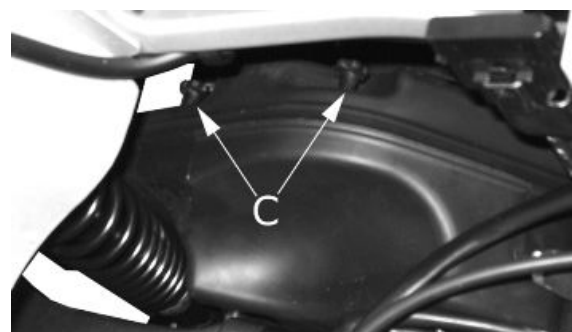
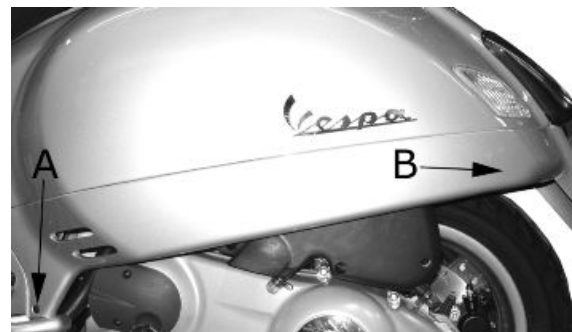

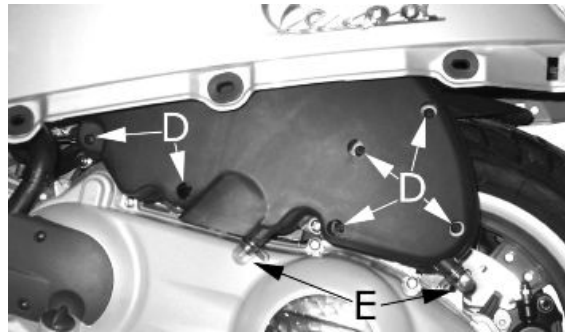

Engine oil

In 4T engines, the engine oil is used to lubricate the distribution elements, the bench bearings and the thermal group. **An insufficient quantity of oil can cause serious damage to the engine.**

In all 4T engines, the deterioration of the oil characteristics, or a certain consumption should be considered normal, especially if during the run-in period. Consumption levels in particular can be influenced by the conditions of use (e.g.: oil consumption increases when driving at "full throttle").

Replacement

At 1,000 km and after every 10,000 km, the oil and the filter must be changed. The engine must be drained by running off the oil from drainage cap "B" of the flywheel side gauze pre-filter; furthermore to facilitate oil drainage, loosen the cap/dipstick "A". Once all the oil has drained through the drainage hole, unscrew the oil cartridge filter "C" and remove it.

Make sure the pre-filter and drainage plug O-rings are in good conditions.

Lubricate them and refit the mesh filter and oil drainage plug, screwing them up to the specified torque.

Refit the new cartridge filter being careful to lubricate the O-ring before fitting it.

Change the engine oil.

Since a certain quantity of oil still remains in the circuit, oil must be filled from cap "A". Then start up the scooter, leave it running for a few minutes and switch it off: after five minutes check the level

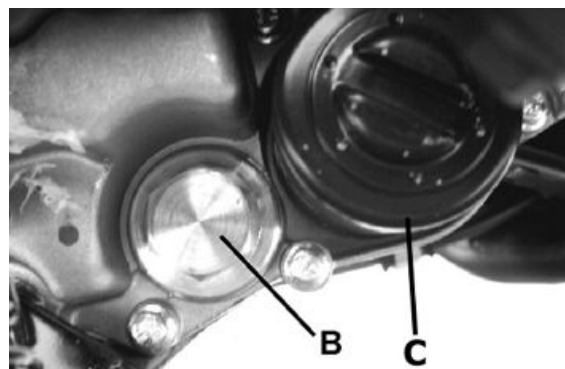

and if necessary top up without exceeding the **MAX** level. The cartridge filter must be replaced every time the oil is changed. Use new oil of the recommended type for topping up and changing purposes.

N.B.

THE ENGINE MUST BE HOT WHEN THE OIL IS CHANGED.

Recommended products

AGIP CITY HI TEC 4T Engine oil

SAE 5W-40 Synthetic oil that exceed the requirements of API SL, ACEA A3, JASO MA specifications

Check

This operation must be carried out with the engine cold and following the procedure below:

1. Place the vehicle on its centre stand and on flat ground.
2. Undo cap/dipstick "A", dry it off with a clean cloth and replace it, **screwing down completely**.
3. Remove the cap/dipstick again and check that the level is between the min and max. marks; top up if necessary.

The MAX level mark indicates a quantity of around 1300 cc of engine oil. If the check is carried out after the vehicle has been used, and therefore with a hot engine, the level line will be lower; in order to carry out a correct check, wait at least 10 minutes after the engine has been stopped so as to get the correct level.

Oil top up

The oil should be topped up after having checked the level and in any case by adding oil **without ever exceeding the MAX. level**.

Restoration of the level from **MIN** to **MAX** requires approximately **200 cc**.



Engine oil filter

The cartridge filter must be replaced every time the oil is changed. Use new oil of the recommended type for topping up and changing purposes.

Make sure the pre-filter and drainage plug O-rings are in good conditions. Lubricate them and refit the mesh filter and oil drainage plug, screwing them up to the specified torque. Refit the new cartridge filter being careful to lubricate the O-ring before fitting it. Change the engine oil.

Recommended products

AGIP CITY HI TEC 4T Engine oil

SAE 5W-40 Synthetic oil that exceed the requirements of API SL, ACEA A3, JASO MA specifications

Oil pressure warning light

The vehicle is equipped with a warning light on the instrument panel that lights up when the key is turned to the «ON» position. However, this light should switch off once the engine has been started.

If the light turns on during braking, at idling speed or while turning a corner, it is necessary to check the oil level and the lubrication system.

Checking the ignition timing

- Remove the plastic cap on the flywheel cover
- Turn the flywheel until the reference mark «T» on the rotor matches the reference mark on the flywheel cover as shown in the figure (TDC). Make sure that the 4V reference point on the camshaft control pulley is aligned with the reference point on the head as shown in the second figure. If the reference is opposite the indicator on the head, turn the crankshaft once more.



For the use of this reference mark, remove the spark plug and turn the engine in the direction that is the reverse of the normal direction using a caliper spanner applied to the camshaft command pulley casing.



Cooling system

Adding engine coolant.

The fluid level must be checked every 10,000 kilometres with a cold engine, in the way shown below: Place the scooter on its centre stand and on flat ground.

- Undo the screw shown in the figure and remove the expansion tank cap on RHS.



- Top up if the fluid level is near or below the MIN level edge. The liquid level must always be between the MIN and MAX level.

-The coolant consists of an ethylene glycol and corrosion inhibitor based 50% de-ionised water-antifreeze solution mix.

CAUTION

DO NOT EXCEED THE MAX. LEVEL WHEN FILLING SO AS TO AVOID THE COOLANT ESCAPING FROM THE EXPANSION TANK WHEN THE vehicle IS IN USE.



Braking system

Level check

The brake fluid tanks for the front and rear brakes are located on the pumps under the handlebar cover. Proceed as follows:

- Remove the brake pump cover
- Rest the vehicle on its centre stand with the handlebars perfectly horizontal;
- Check the fluid level through the sight glass as shown in the figure. A certain lowering of the level is caused by wear on the pads.



Top-up

- Position the vehicle on a flat surface and on the centre stand
- Remove the brake pump cover as indicated in the photo



- Check the brake fluid level through the sight glass on the pump as shown in the photograph
- If the level is below the minimum, fill using the two screws shown in the figure



- Remove the gasket and fill with DOT 4 until the spyglass is completely covered

For refitting purposes carry out the operations in the reverse order from the removal operation and respect the tightening torque of the tank cover screws.

CAUTION



AVOID CONTACT OF THE BRAKE FLUID WITH YOUR EYES, SKIN, AND CLOTHING. IN CASE OF ACCIDENTAL CONTACT, WASH WITH WATER.

CAUTION



THE BRAKING CIRCUIT FLUID IS HIGHLY CORROSIVE. THEREFORE, WHEN TOPPING IT UP, AVOID LETTING IT COME INTO CONTACT WITH THE PAINTED PARTS OF THE VEHICLE. THE BRAKING CIRCUIT FLUID IS HYGROSCOPIC, THAT IS, IT ABSORBS HUMIDITY FROM THE SURROUNDING AIR. IF MOISTURE CONTAINED IN THE BRAKE FLUID EXCEEDS A CERTAIN VALUE, THIS WILL RESULT IN INEFFICIENT BRAKING.

CAUTION

NEVER USE BRAKE FLUID COMING FROM OPEN OR PARTIALLY USED CONTAINERS. UNDER NORMAL CLIMATIC CONDITIONS, BRAKE FLUID MUST BE CHANGED EVERY 20,000 KM OR ANYWAY EVERY 2 YEARS.

Locking torques (N*m)

Brake pump reservoir screws 15 ÷ 20



Headlight adjustment

Proceed as follows:

1. Place the vehicle in running order and with the tyres inflated to the prescribed pressure, on a flat surface 10 m away from a white screen situated in a shaded area, making sure that the longitudinal axis of the scooter is perpendicular to the screen;
2. Turn on the headlight and check that the borderline of the projected light beam on the screen is not lower than $\frac{9}{10}$ of the distance from the ground to the centre of vehicle headlamp and higher than $\frac{7}{10}$;
3. If otherwise, adjust the right headlight with screw «A».

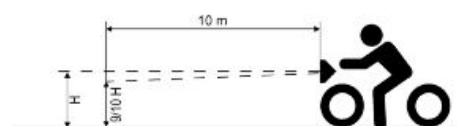
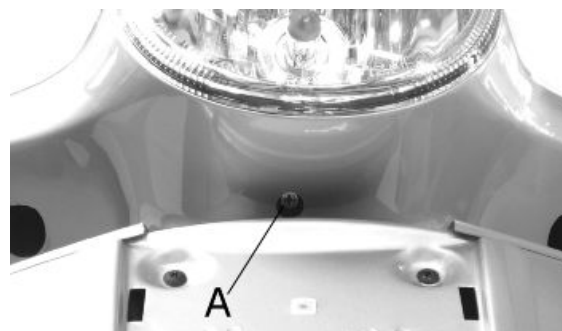

N.B.

THE ABOVE PROCEDURE COMPLIES WITH THE EUROPEAN STANDARDS REGARDING MAXIMUM AND MINIMUM HEIGHT OF LIGHT BEAMS. REFER TO THE STATUTORY REGULATIONS IN FORCE IN EVERY COUNTRY WHERE THE vehicle IS USED.

INDEX OF TOPICS

TROUBLESHOOTING

TROUBL

This section makes it possible to find what solutions to apply when troubleshooting.
For each failure, a list of the possible causes and pertaining operations is given.

Engine

Excessive oil consumption/Exhaust smoke

EXCESSIVE CONSUMPTION

Possible Cause	Operation
Wrong valve adjustment	Adjust the valve clearance properly
Overheated valves	Remove the head and the valves, grind or replace the valves
Misshapen/worn valve seats	Replace the head assembly
Worn cylinder, Worn or broken piston rings	Replace the piston cylinder assembly or piston rings
Worn or broken piston rings or piston rings that have not been fitted properly	Replace the piston cylinder unit or just the piston rings
Oil leaks from the couplings or from the gaskets	Check and replace the gaskets or restore the coupling seal
Worn valve oil guard	Replace the valve oil guard
Worn valve guides	Check and replace the head unit if required

Insufficient lubrication pressure

SCARSA PRESSIONE DI LUBRIFICAZIONE

Possible Cause	Operation
By-Pass remains open	Check the By-Pass and replace if required. Carefully clean the By-Pass area.
Oil pump with excessive clearance	Perform the dimensional checks on the oil pump components
Oil filter too dirty	Replace the cartridge filter
Oil level too low	Restore the level adding the recommended oil type

Transmission and brakes

Clutch grabbing or performing inadequately

IRREGULAR CLUTCH PERFORMANCE OR SLIPPAGE

Possible Cause	Operation
Faulty clutch	Check that there is no grease on the masses. Check that the clutch mass contact surface with the casing is mainly in the centre with equivalent characteristics on the three masses. Check that the clutch casing is not scored or worn in an anomalous way

Insufficient braking

INEFFICIENT BRAKING SYSTEM

Possible Cause	Operation
Inefficient braking system	Check the pad wear (1.5 min). Check that the brake discs are not worn, scored or warped. Check the correct level of fluid in the pumps and change brake fluid if necessary. Check there is no air in the circuits; if necessary, bleed the air. Check that the front brake calliper moves in axis with the disc.
Fluid leakage in hydraulic braking system	Failing elastic fittings, plunger or brake pump seals, replace

Possible Cause	Operation
Brake disc slack or distorted	Check the brake disc screws are locked; measure the axial shift of the disc with a dial gauge and with wheel mounted on the scooter.

Brakes overheating

BRAKES OVERHEATING

Possible Cause	Operation
Defective sliding of pistons	Check calliper and replace any damaged part.
Brake disc slack or distorted	Check the brake disc screws are locked; use a dial gauge and a wheel mounted on the vehicle to measure the axial shift of the disc.
Clogged compensation holes on the pump	Clean carefully and blast with compressed air
Swollen or stuck rubber gaskets	Replace gaskets.

Steering and suspensions

Heavy steering

STEERING HARDENING

Possible Cause	Operation
Steering hardening	Check the tightening of the top and bottom ring nuts. If irregularities in turning the steering continue even after making the above adjustments, check the seats on which the ball bearings rotate: replace them if they are recessed or if the balls are flattened.

Excessive steering play

EXCESSIVE STEERING CLEARANCE

Possible Cause	Operation
Torque not conforming	Check the tightening of the top and bottom ring nuts. If irregularities in turning the steering continue even after making the above adjustments, check the seats on which the ball bearings rotate: replace them if they are recessed or if the balls are flattened.

Noisy suspension

NOISY SUSPENSION

Possible Cause	Operation
Malfunctions in the suspension system	If the front suspension is noisy, check: the efficiency of the front shock absorbers; the condition of the ball bearings and relevant lock-nuts, the limit switch rubber buffers and the movement bushings. In conclusion, check the tightening torque of the wheel hub, the brake calliper, the shock absorber disk in the attachment to the hub and the steering tube.

Suspension oil leakage

OIL LEAKAGE FROM SUSPENSION

Possible Cause	Operation
Seal fault or breakage	Replace the shock absorber Check the condition of wear of the steering covers and the adjustments.

INDEX OF TOPICS

ELECTRICAL SYSTEM

ELE SYS

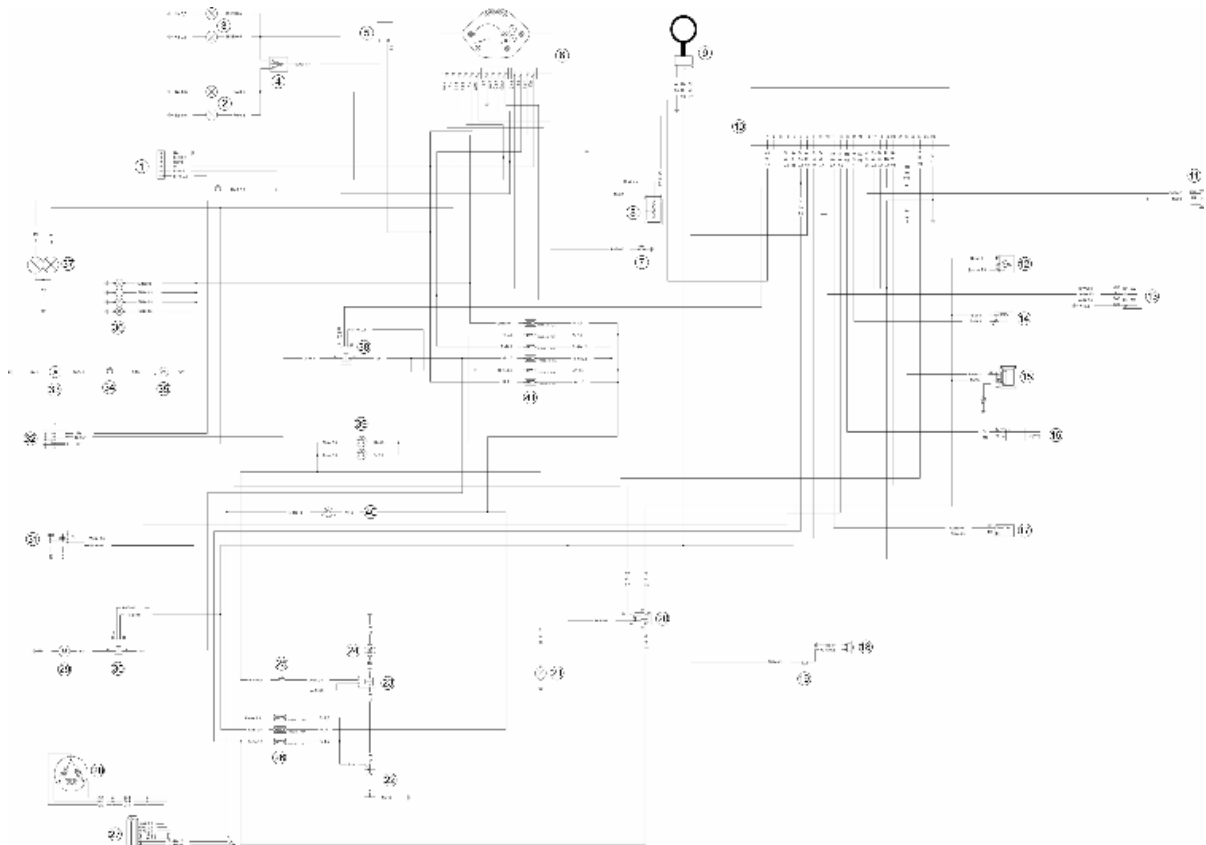
**KEY**

1. Pre-installation for anti-theft device
2. Left turn indicator bulbs
3. Right turn indicator bulbs
4. Turn indicator switch
5. Turn indicator control device
6. Instrument panel
7. Oil pressure sensor
8. Fuel level transmitter
9. Immobilizer aerial
10. Injection ECU
11. Diagnostics socket
12. Fuel pump
13. Engine temperature sensor
14. Fuel injector
15. HV coil
16. Engine rpm sensor
17. Lambda probe
18. Horn
19. Horn button

- 20. Injection load remote control
- 21. Stop light bulb
- 22. Battery
- 23. Start-up remote control
- 24. Starter motor
- 25. Starter button
- 26. Main fuses
- 27. Voltage regulator
- 28. Magneto flywheel
- 29. Radiator electric fan
- 30. Remote control for electric fan
- 31. Engine stop switch
- 32. Light switch
- 33. Saddle opening actuator
- 34. Saddle opening button
- 35. Key switch contacts
- 36. Tail lights and license plate light bulbs
- 37. Headlight with twin-filament light bulb
- 38. Headlight remote control
- 39. Stop buttons
- 40. Key switch contacts
- 41. Auxiliary fuses

Key

Ar: Orange **Az:** Sky blue **Bi:** White **Bl:** Blue **Gi:** Yellow **Gr:** Grey

Ma: Brown **Ne:** Black **Ro:** Pink **Rs:** Red **Ve:** Green **Vi:** Purple

Components arrangement

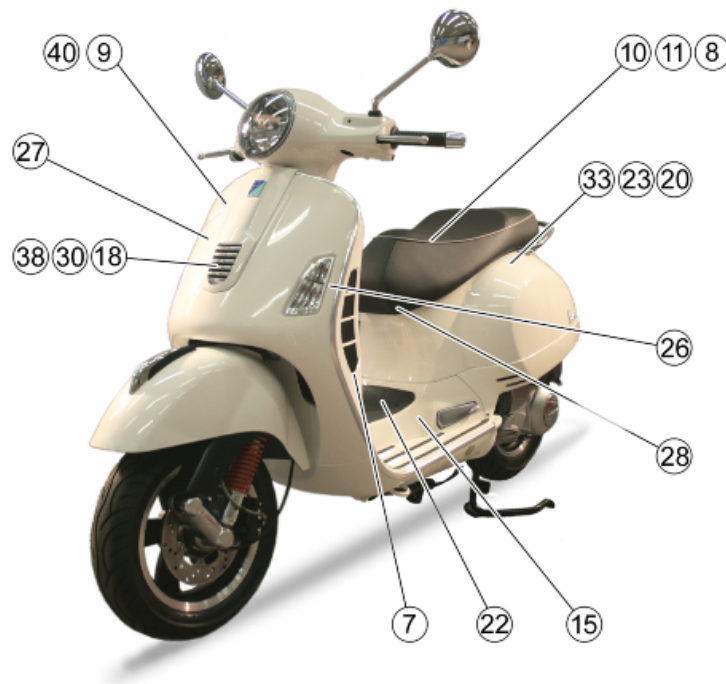

9. Immobilizer aerial - Remove the shield back plate to reach it.

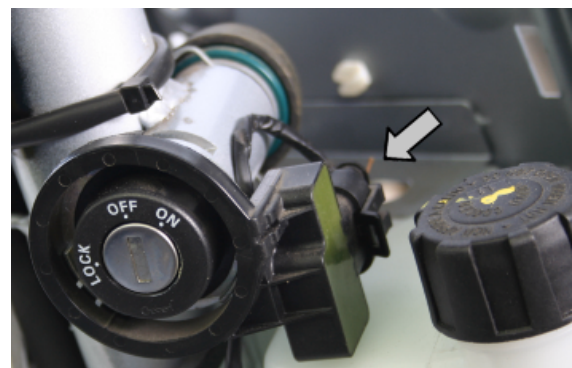

10. Injection ECU - Remove the helmet compartment to reach it.

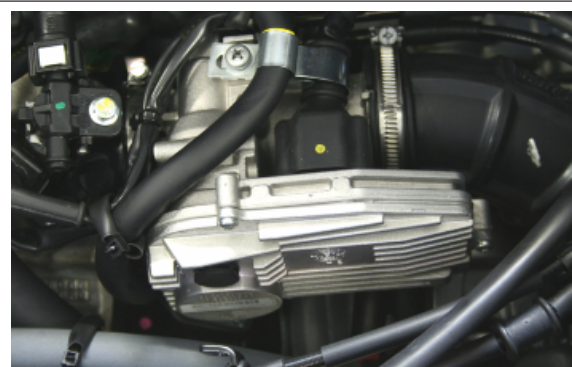

11. Diagnosis connector - Remove the helmet compartment to reach it.



15. HV coil - Remove the battery to reach it; to remove the coil, first remove the footrest and undo the two screws indicated.

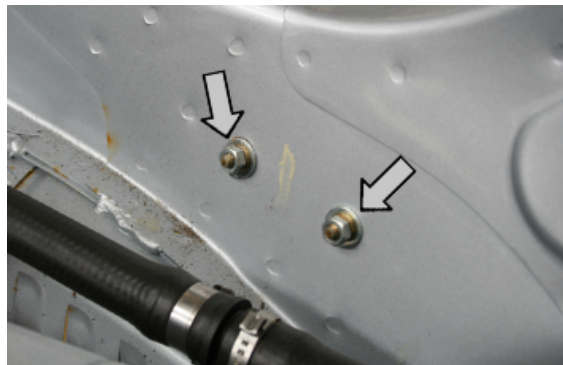

18-30-38 Horn - Remote control switches Remove front central cover to reach it.

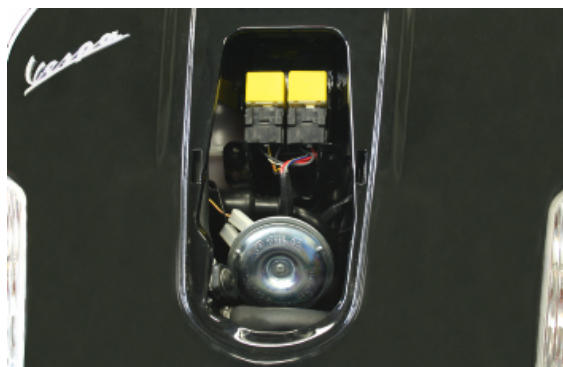

20-23. Remote control switches - Remove the front central cover and the helmet compartment to reach them.



26. Main fuses - Open the front top box to reach them.



41. Auxiliary fuses - Remove the helmet compartment to reach them.



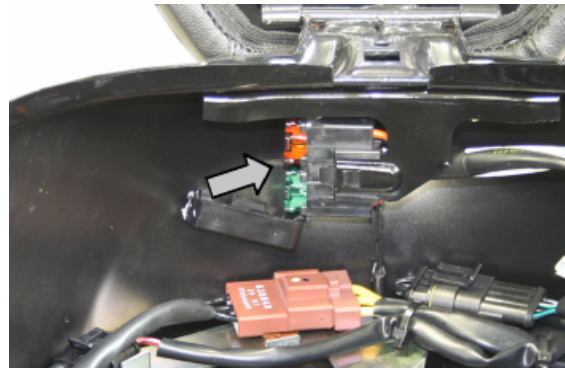

27. Voltage regulator - Remove the shield back plate to reach it.



28. Magneto flywheel - Remove the flywheel cover, as described in the «Engine» chapter, to reach it. To get access to the connectors, remove the helmet compartment.

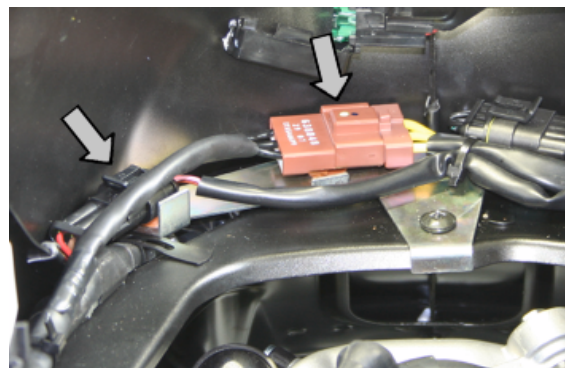

40. Key switch contacts - Remove the shield back plate to reach them.



33. Saddle-opening actuator - Remove the helmet compartment to reach it, undo the two screws indicated and remove the mounting bracket together with the actuator.



8. Fuel level transmitter - Remove the fuel tank to reach it.

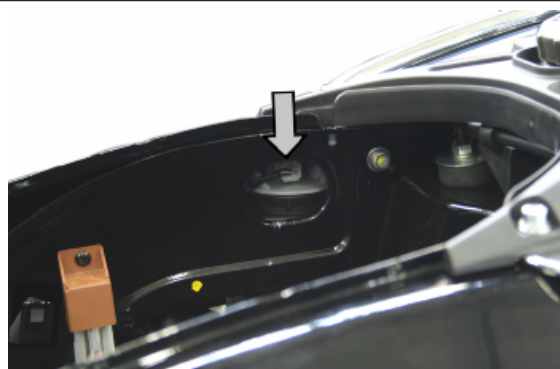

7. Oil pressure sensor - Remove the right side fairing to reach it.



22. Battery - Remove the rear central cover to reach it.



Ground points

On the vehicle there is a ground point on the chassis marked with the letter "A"

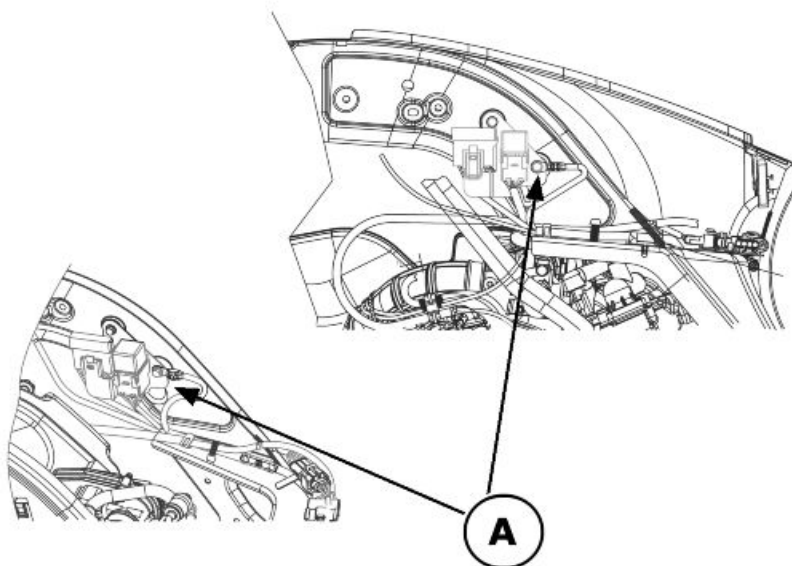

There is another ground point "B" on the starter motor.

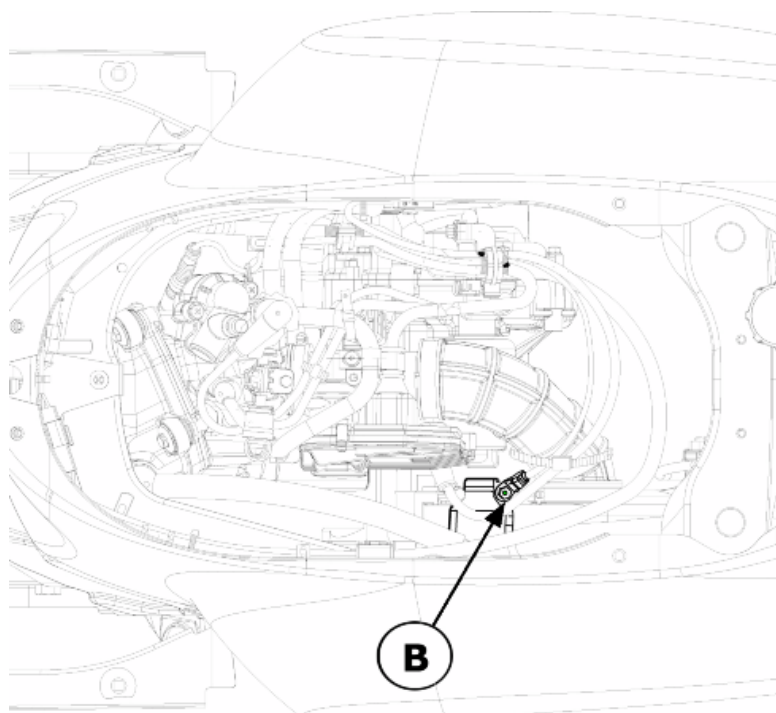

Electrical system installation

Front side

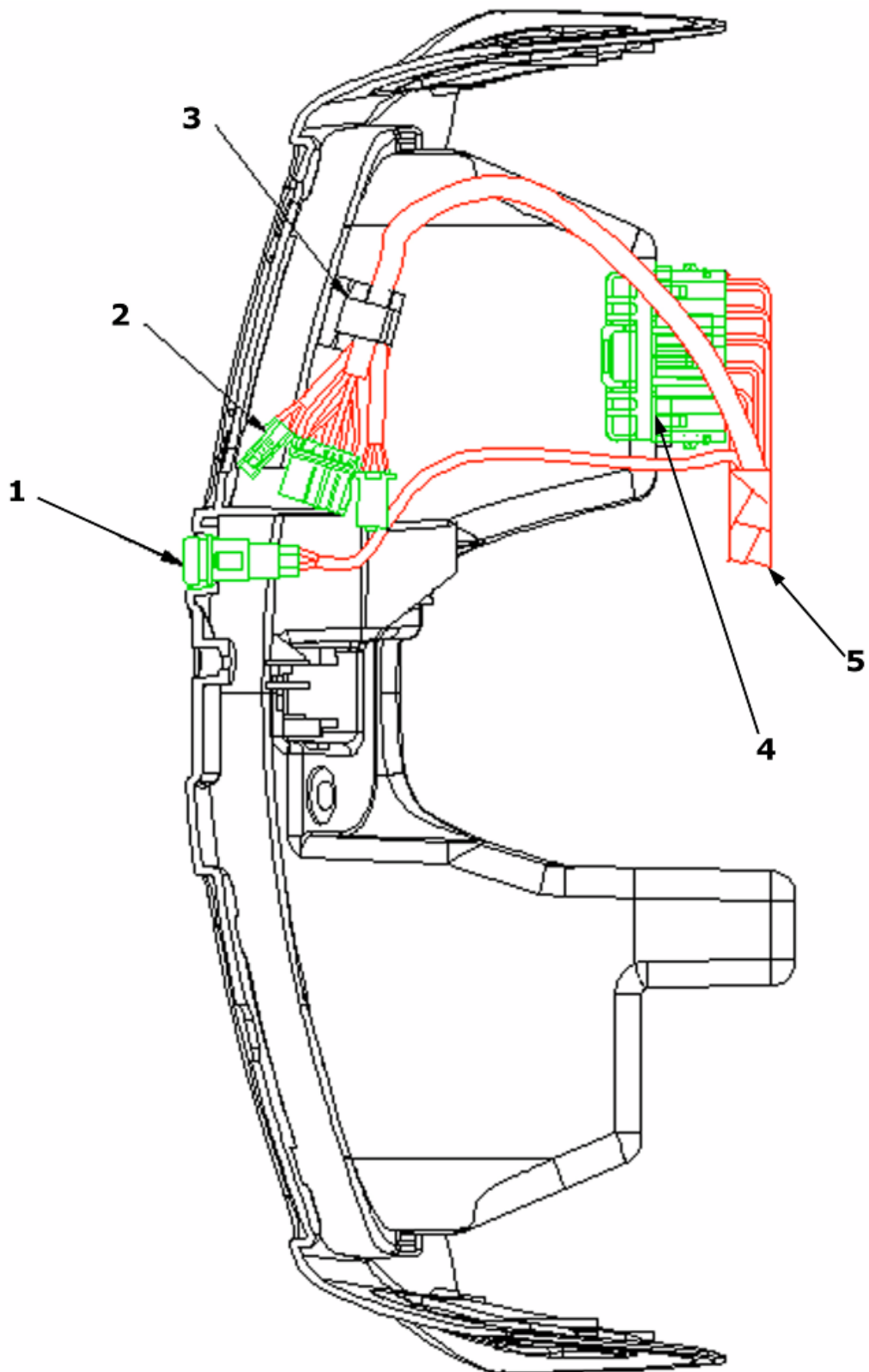

- 1. Saddle opening switch
- 2. Pre-installations

3. Insert in clamp
4. Fuse box
5. From the wire unit

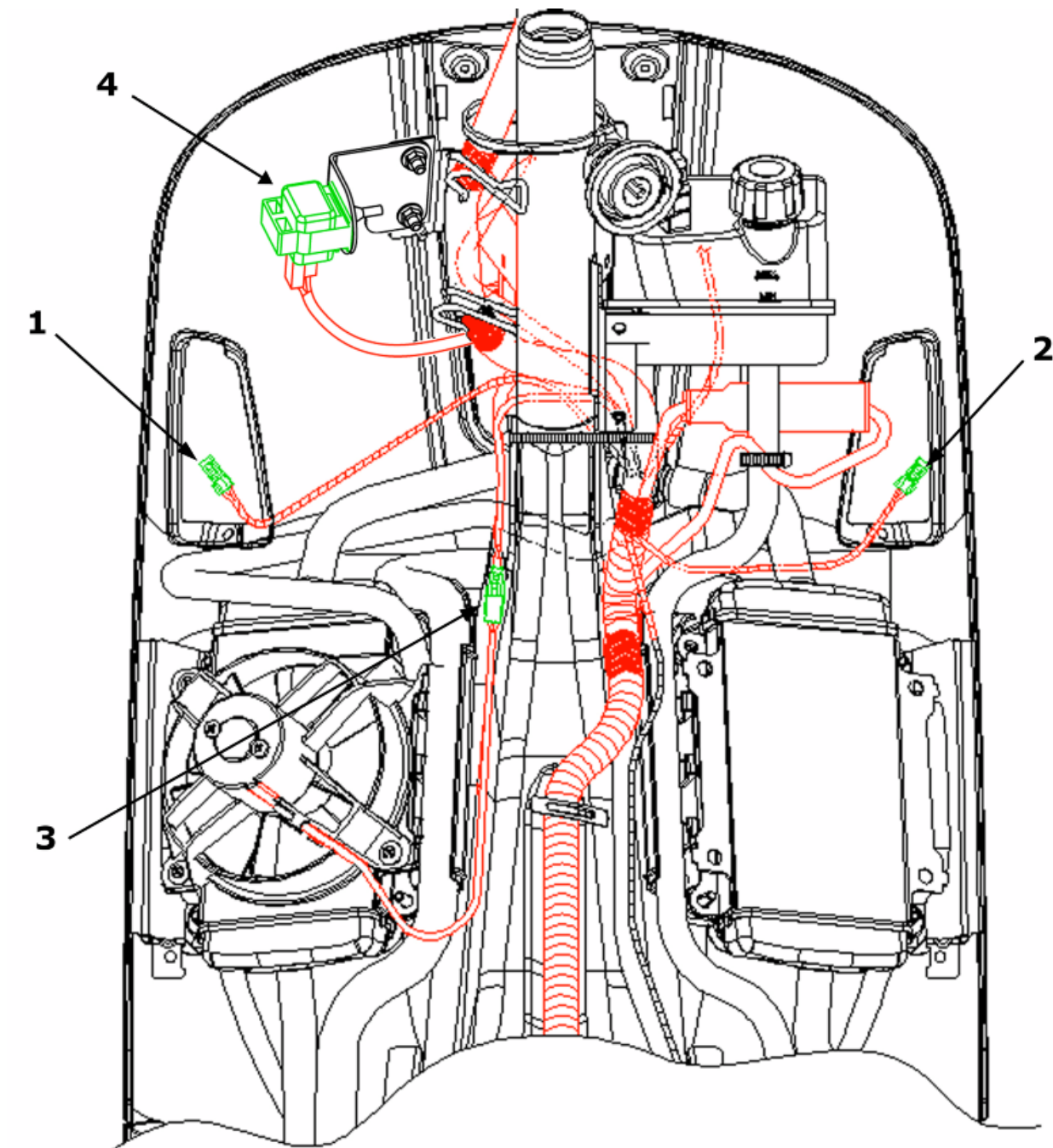

1. Front left turn indicator connector
2. Front right turn indicator connector
3. Electrical fan connector
4. Turn indicator control device

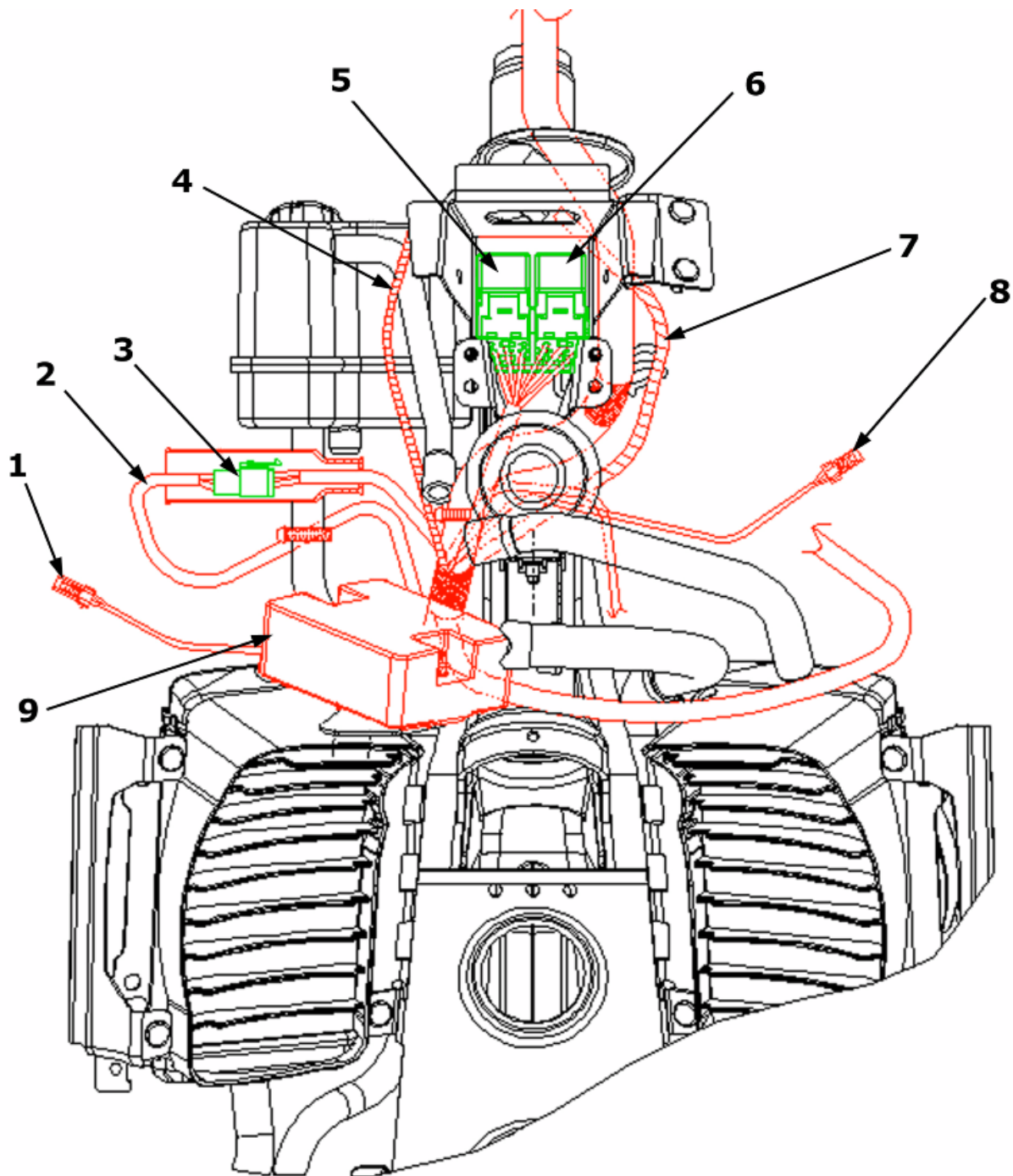

1. Right turn indicator connector
2. From regulator
3. Wire unit - regulator connection
4. To the immobilizer aerial
5. Light remote control
6. Electric fan remote control
7. To key switch
8. Left turn indicator connector

9. Voltage regulator

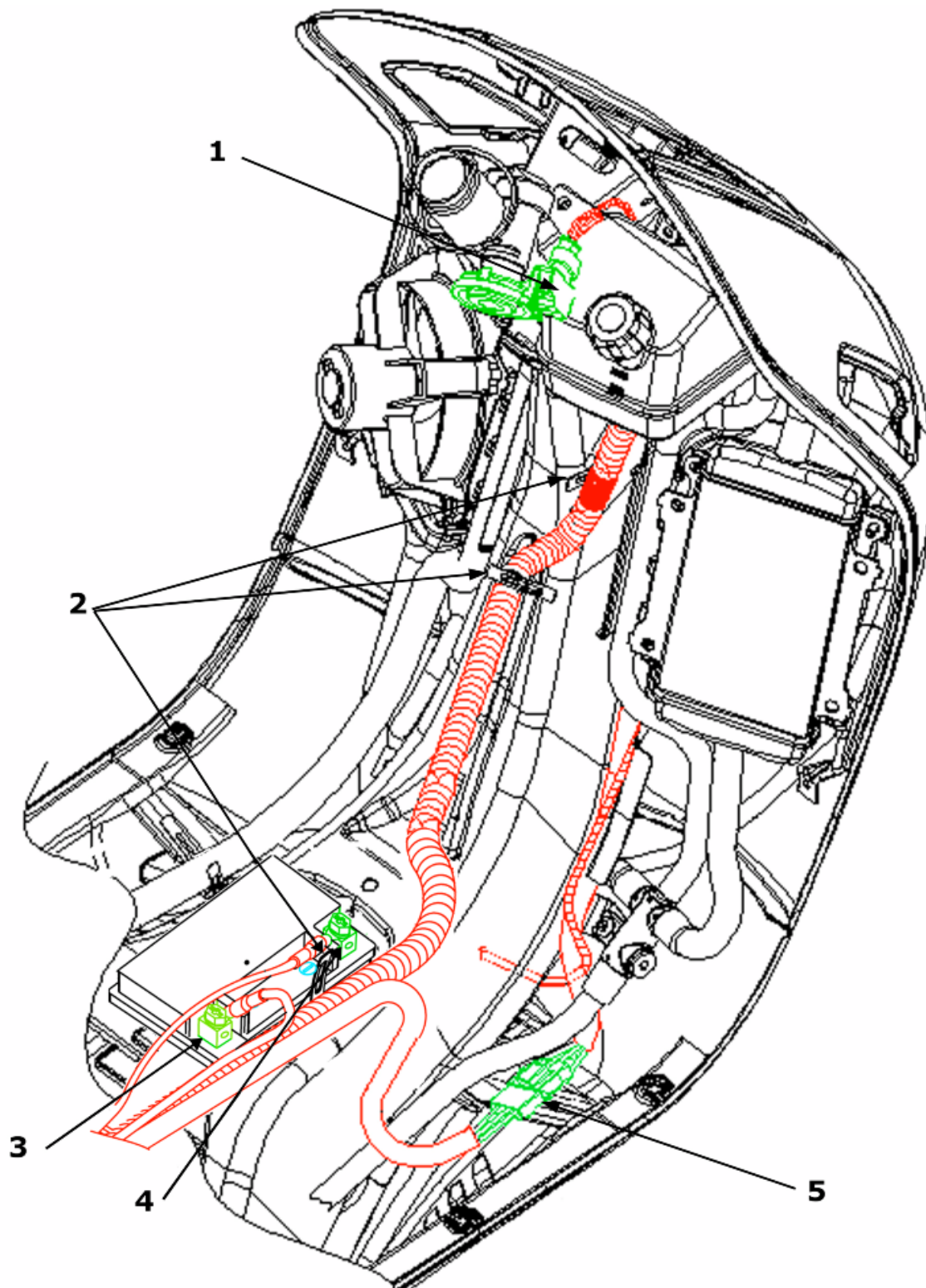

1. Immobilizer aerial
2. Foldable clamp to hold cables
3. Battery negative terminal

4. Battery positive terminal
5. Flywheel - regulator connection

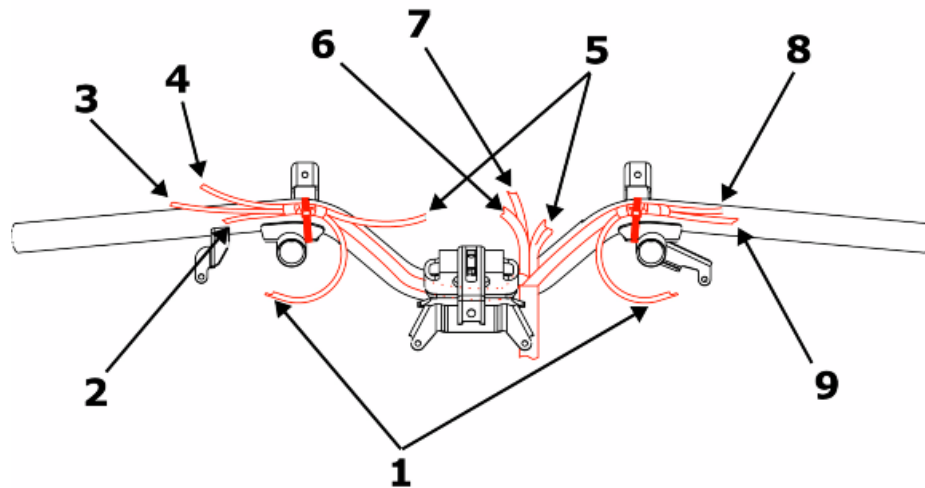

1. To stop switch
2. To turn indicator switch
3. To light switch
4. To horn button
5. To instrument panel
6. To headlight
7. To position light
8. To starter button
9. To engine stop switch

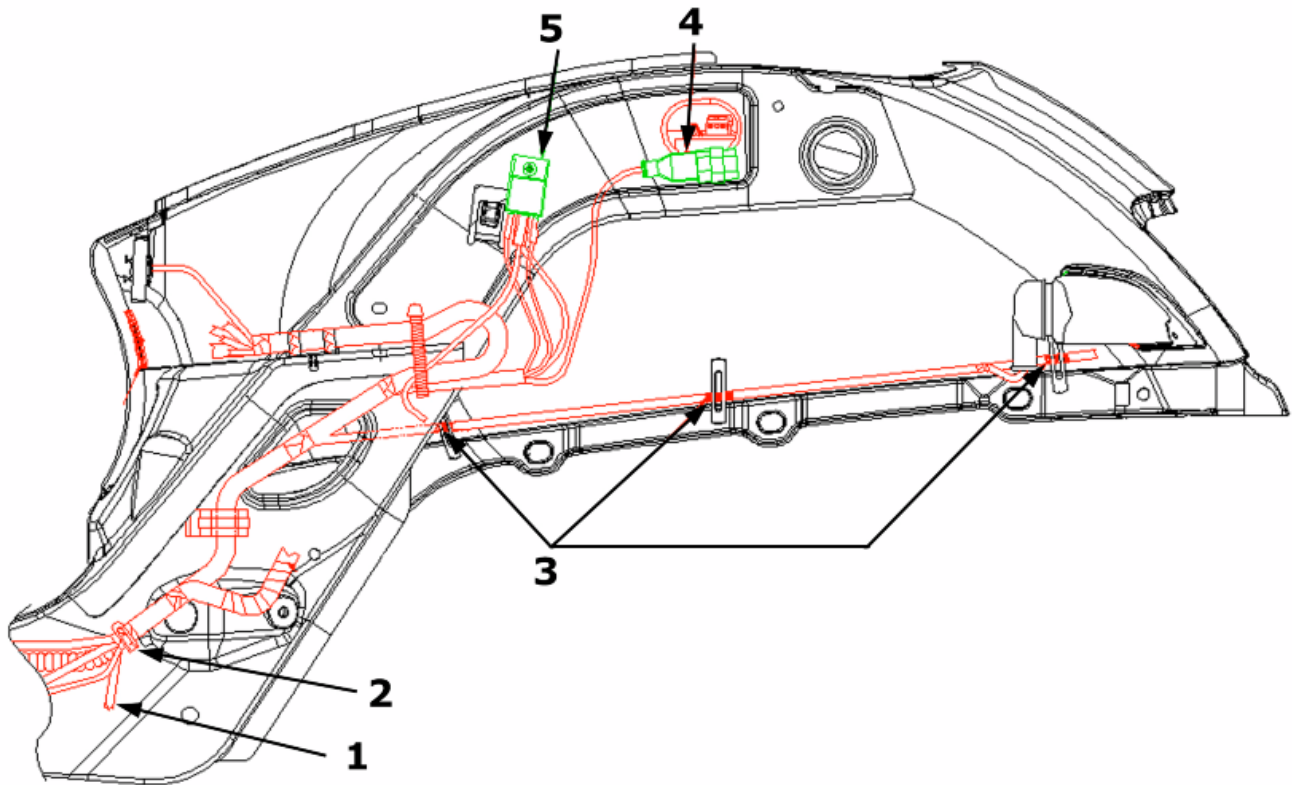
Back side

1. To HV coil
2. Foldable clamp
3. Foldable clamps to hold the red sheathing
4. Diagnostic socket
5. Starter remote control

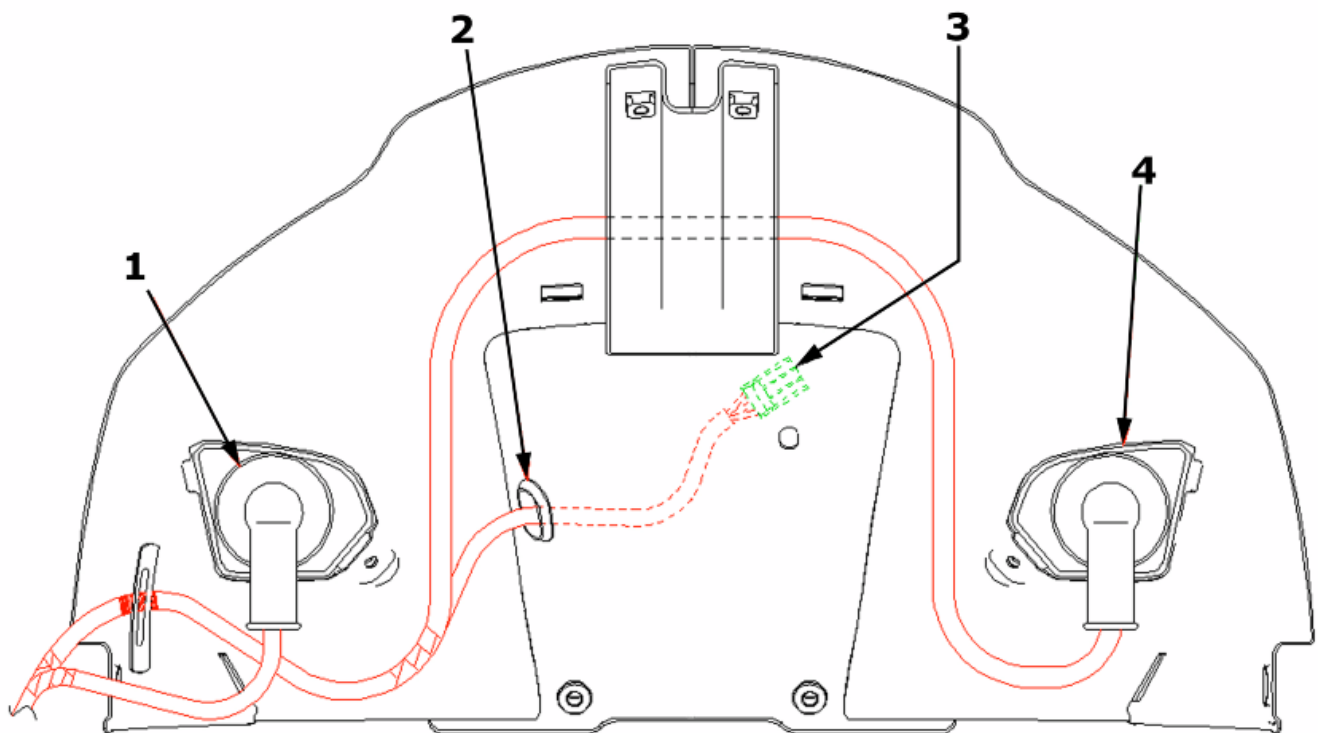

1. Rear right turn indicator
2. Cable guide
3. To rear light
4. Rear left turn indicator

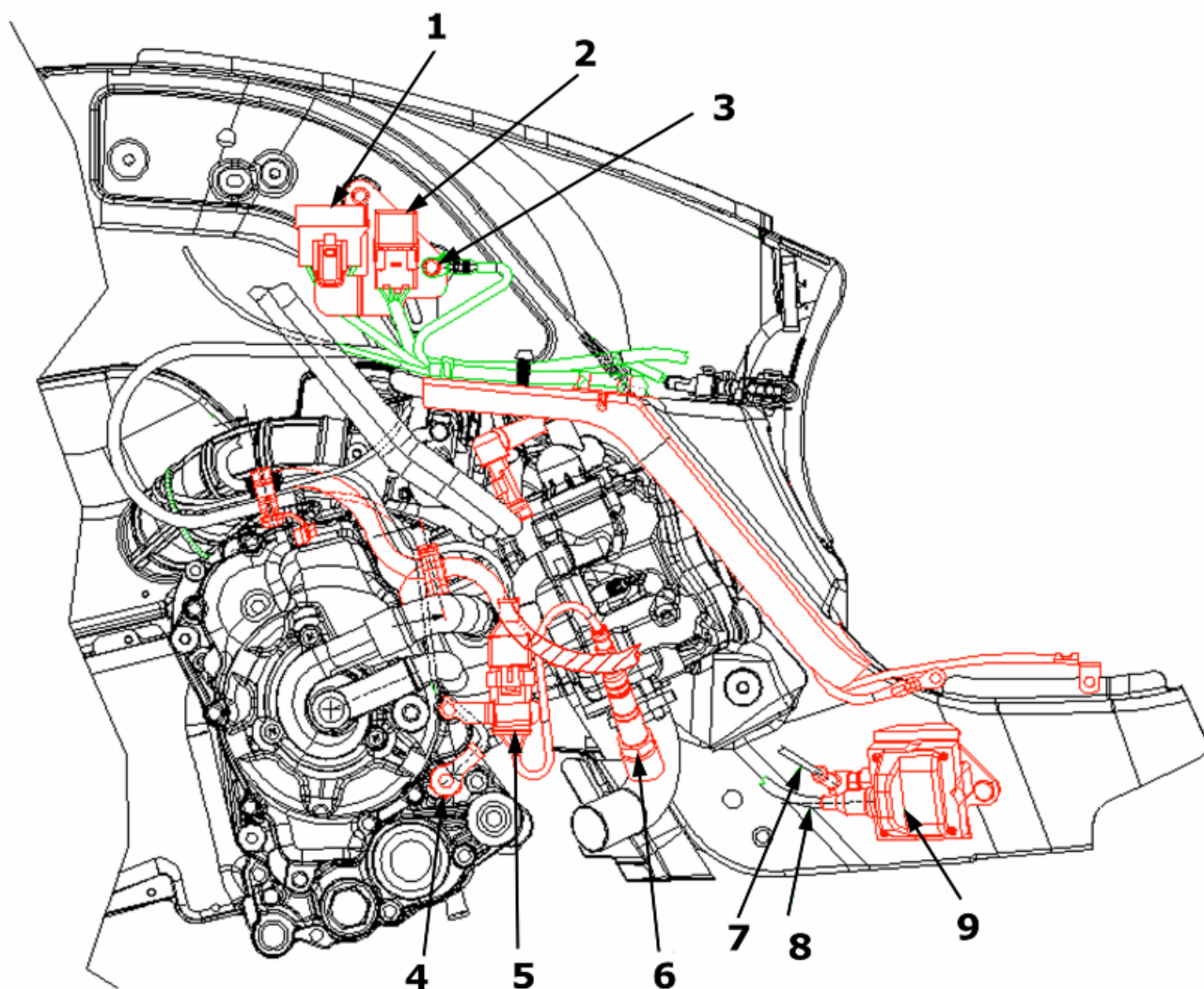

1. Fuse box
2. Remote control switch
3. Ground lead clamping to chassis
4. Oil pressure sensor
5. Lambda probe connector
6. Lambda sensor
7. To wire unit
8. To the spark plug
9. HV coil

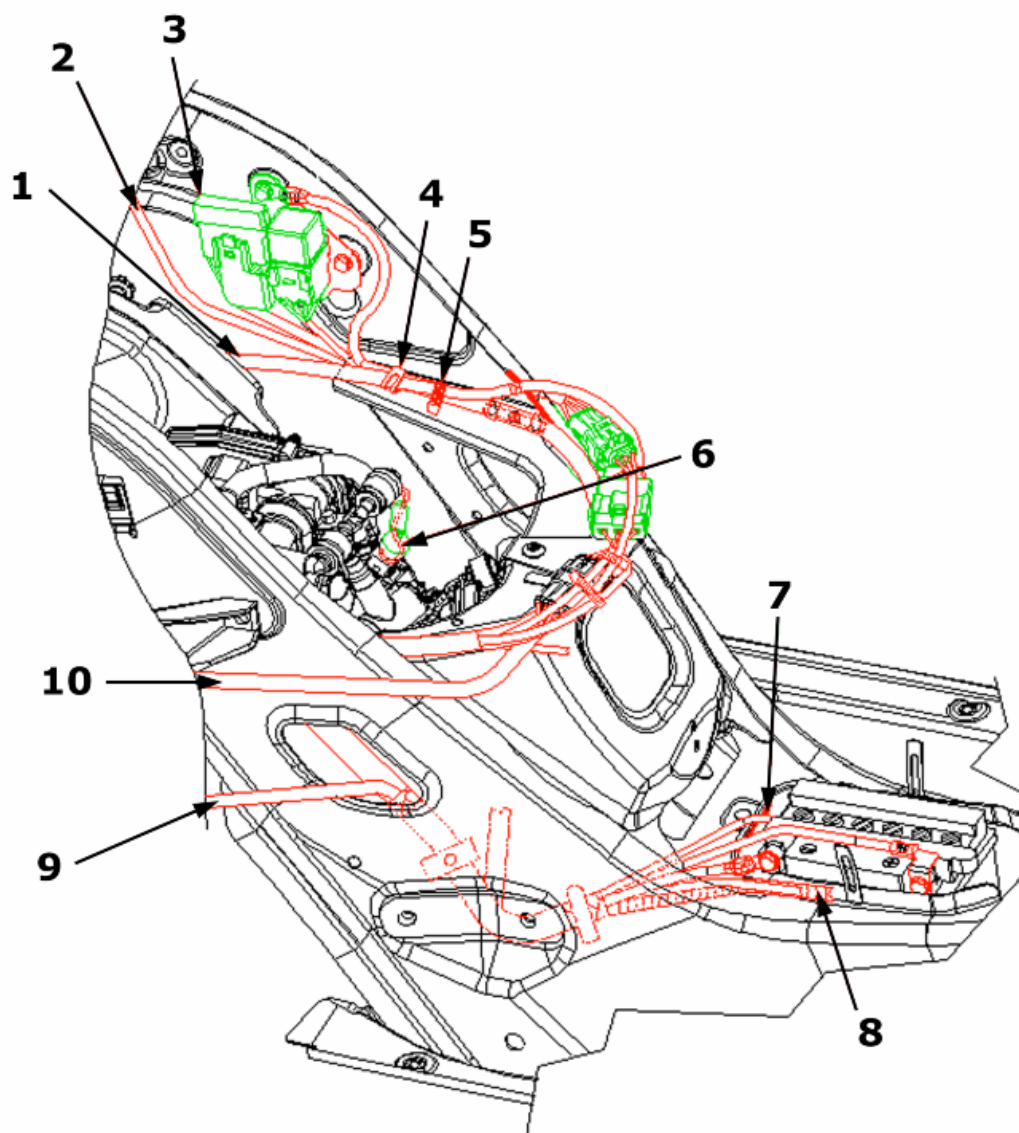

1. To flywheel
2. To saddle opening actuator
3. Fuse box
4. Foldable clamp to hold cables
5. Clamp
6. Injector connector
7. To HV coil
8. To front wire unit
9. To rear turn indicators
10. To fuel gauge and fuel tank

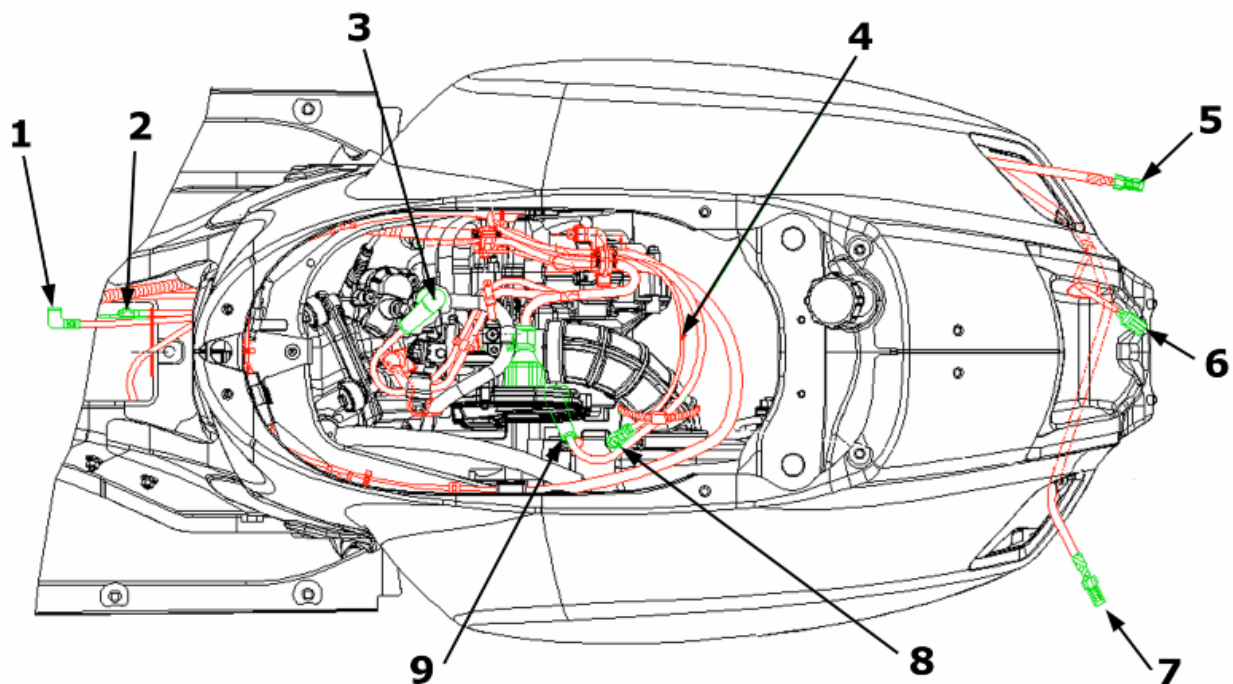

1. Battery positive terminal
2. Battery negative terminal
3. Thermistor
4. Starter motor ground lead
5. Right turn indicator connector
6. Rear headlight assembly connector
7. Left turn indicator connector
8. Starter motor ground lead clamping
9. Starter motor positive terminal

Conceptual diagrams

Ignition

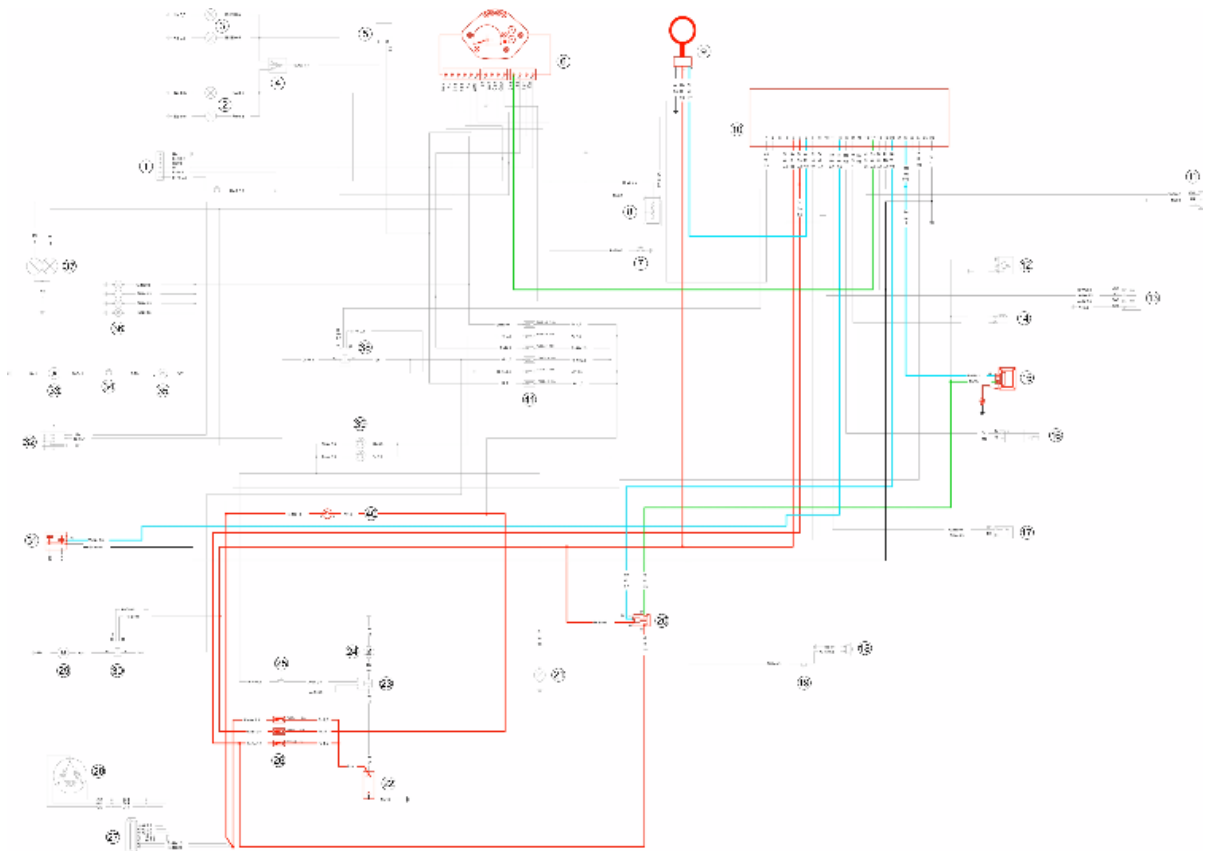

KEY

- 6. Instrument panel
- 9. Immobilizer aerial
- 10. Injection ECU
- 15. HV coil
- 20. Injection load remote control
- 22. Battery
- 26. Main fuses
- 31. Engine stop switch
- 40. Key switch contacts

Battery recharge and starting

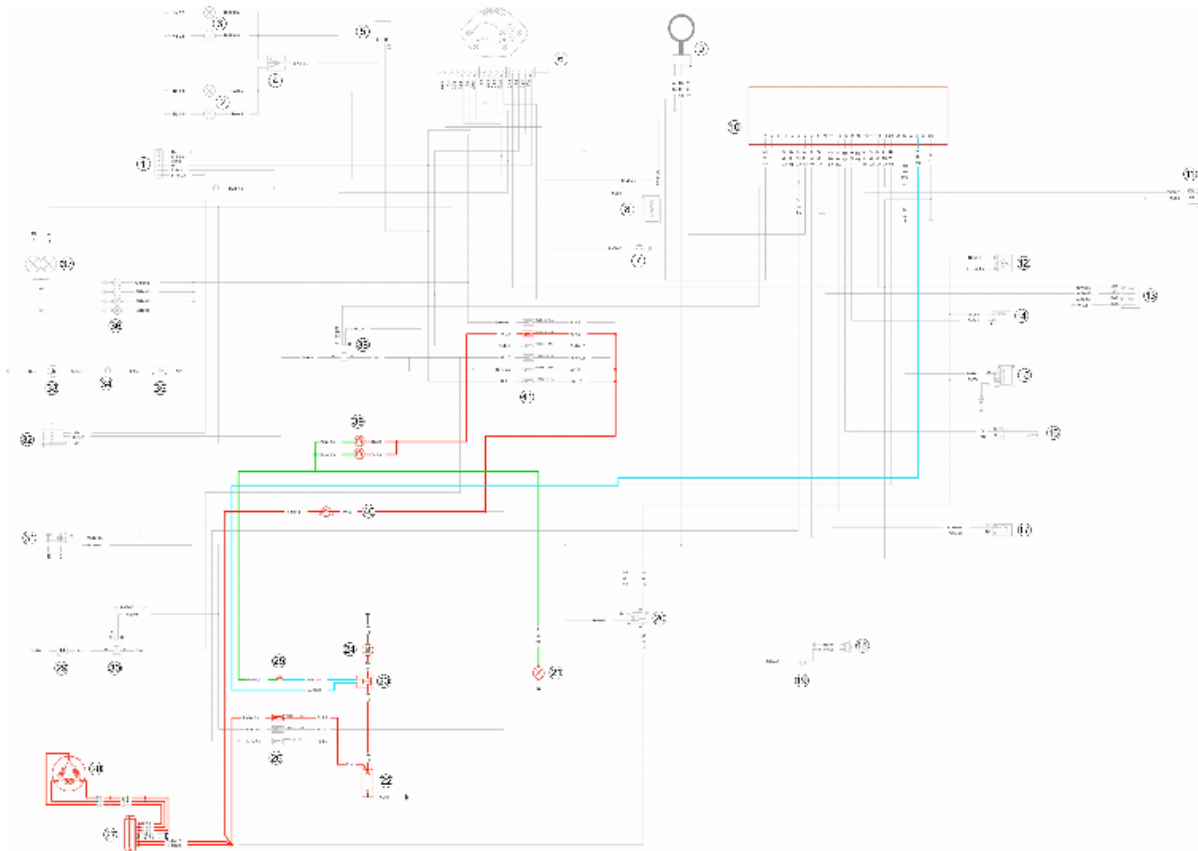

KEY

- 10. Injection ECU
- 21. Stop light bulb
- 22. Battery
- 23. Start-up remote control
- 24. Starter motor
- 25. Starter button
- 26. Main fuses
- 27. Voltage regulator
- 28. Magneto flywheel
- 39. Stop buttons
- 40. Key switch contacts
- 41. Auxiliary fuses

Level indicators and enable signals section

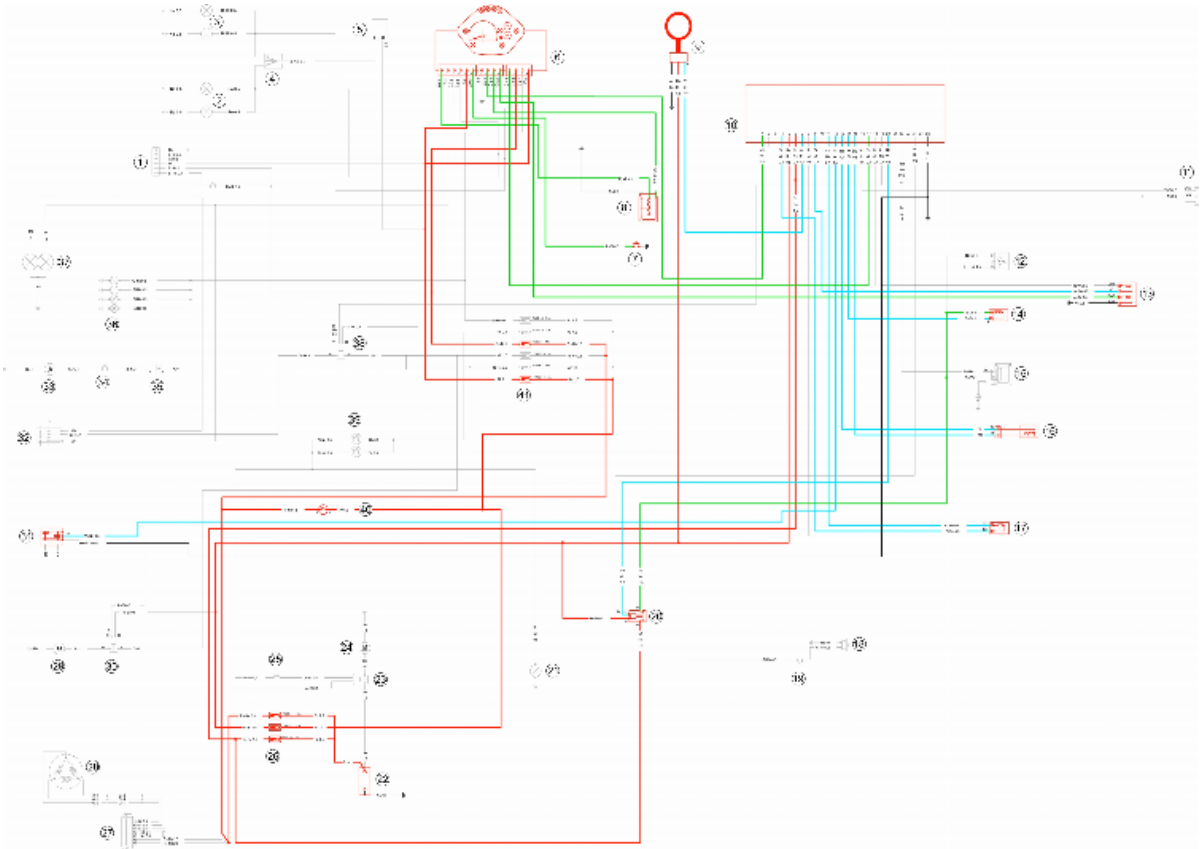

KEY

- 6. Instrument panel
- 7. Oil pressure sensor
- 8. Fuel level transmitter
- 9. Immobilizer aerial
- 10. Injection ECU
- 13. Engine temperature sensor
- 14. Fuel injector
- 16. Engine rpm sensor
- 17. Lambda probe
- 20. Injection load remote control
- 22. Battery
- 26. Main fuses
- 31. Engine stop switch
- 40. Key switch contacts
- 41. Auxiliary fuses

Devices and accessories

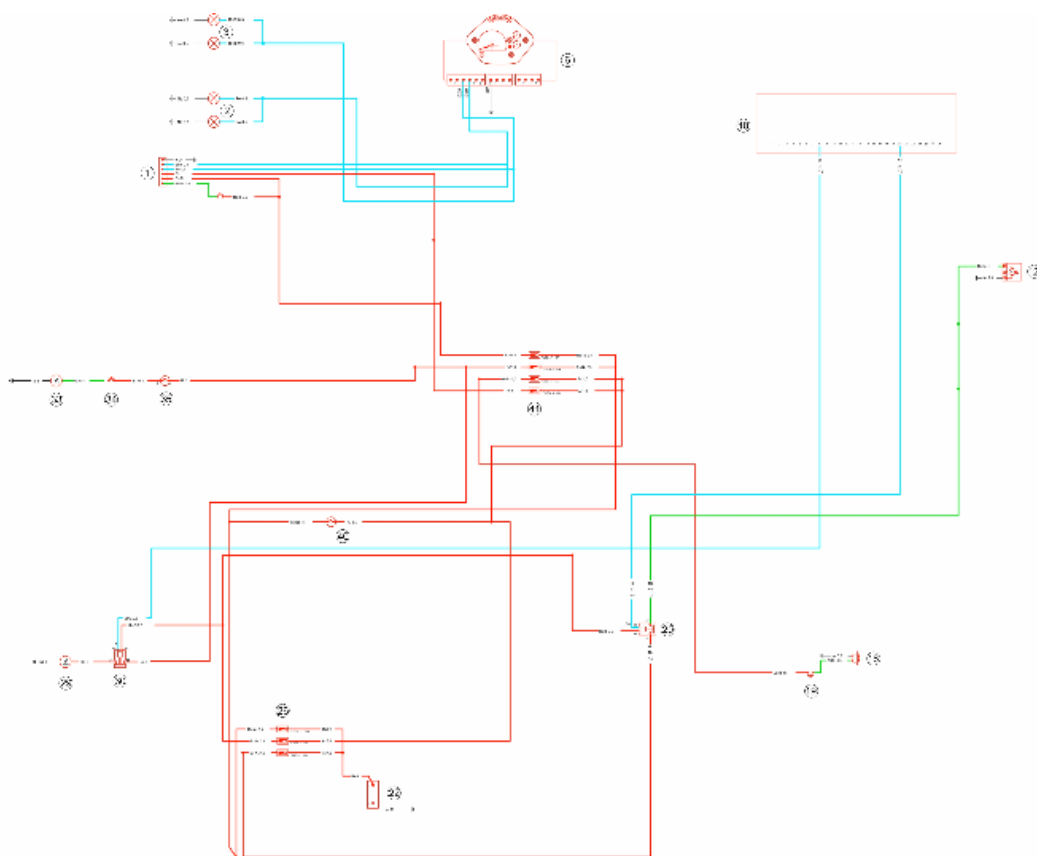

KEY

1. Pre-installation for anti-theft device
2. Left turn indicator bulbs
3. Right turn indicator bulbs
6. Instrument panel
10. Injection ECU
12. Fuel pump
18. Horn
19. Horn button
20. Injection load remote control
22. Battery
26. Main fuses
29. Radiator electric fan
30. Remote control for electric fan
33. Saddle opening actuator
34. Saddle opening button
35. Key switch contacts
40. Key switch contacts

41. Auxiliary fuses

Lights and turn indicators

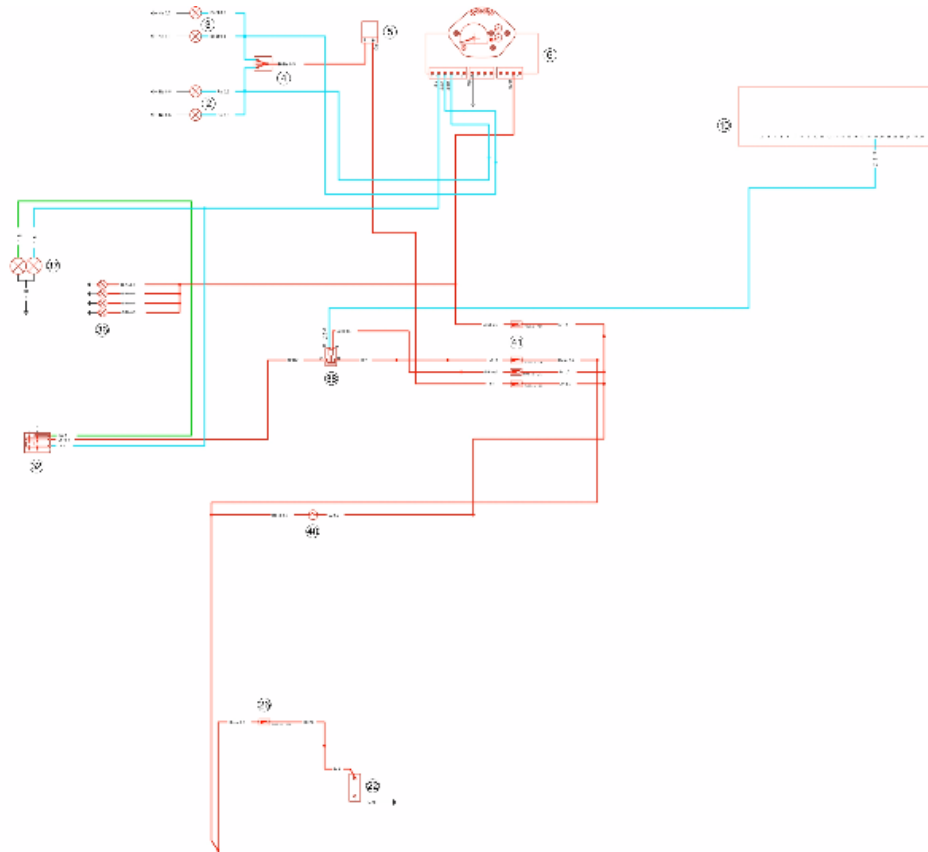

KEY

- 2. Left turn indicator bulbs
- 3. Right turn indicator bulbs
- 4. Turn indicator switch
- 5. Turn indicator control device
- 6. Instrument panel
- 10. Injection ECU
- 22. Battery
- 26. Main fuses
- 32. Light switch
- 36. Tail lights and license plate light bulbs
- 37. Headlight with twin-filament light bulb
- 38. Headlight remote control
- 40. Key switch contacts
- 41. Auxiliary fuses

Checks and inspections

This section is devoted to the checks on the electrical system components.

Immobiliser

The electronic ignition system is controlled by the control unit with the integrated Immobilizer system. The immobilizer is an anti-theft system that allows the vehicle to be operated only when it is started with coded keys recognised by the control unit. The code is integrated in a transponder in the key block. This allows the driver clear operation without having to do anything other than just turning the key. The Immobiliser system consists of the following components:

- Control unit
- Immobilizer aerial
- master and service keys with built-in transponder
- HV coil
- diagnosis LED

The diagnosis LED also works as a theft-deterrent blinker. This function is activated every time the ignition switch is turned to the "OFF" position, or the emergency stop switch is turned to the "OFF" position. It remains activated for 48 hours in order not to affect the battery charge.

When the key switch is turned to "ON", it interrupts the function of the immobiliser lamp and a start enable lamp comes "ON".

The duration of the flash depends on the programming of the electronic control unit

If the LED is off regardless of the position of the ignition-key switch and/or the instrument panel is not initiated, check if:

- there is battery voltage
- that fuse 1 and fuse 8 are in good condition.

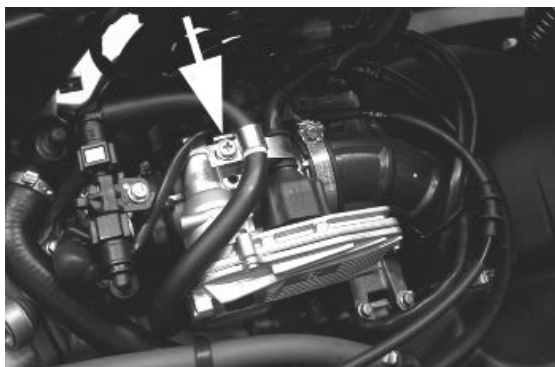

- there is power to the control unit as specified below:

Remove the connector support bracket shown in the photograph and disconnect the connector from the control unit. Check the following conditions:

With the key switch set to OFF:

- there is battery voltage between terminals 6-26 and terminal 6-frame earth (fixed power supply). If there is no voltage check that fuse 4 and its cable are in working order.

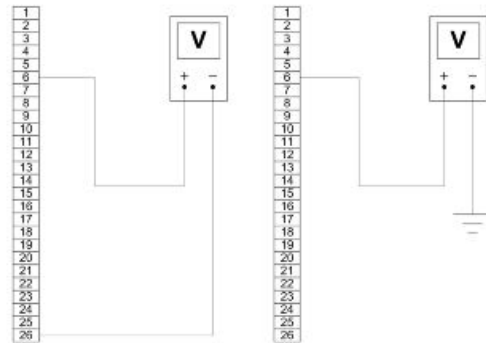

With the key switch set to ON:

- there is battery voltage between terminals 5-26 and terminal 5-frame earth (fixed power supply). If there is no voltage, check the key switch contacts, that fuse 2 and its cable are in working order.

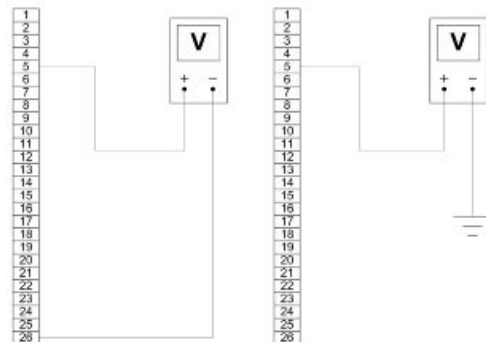

- There is continuity between terminals 12-18 and 12-19 with the emergency cut-out switch in the RUN position. If there is no continuity, check the contacts of the latter.

If no faults are found, replace the control unit.

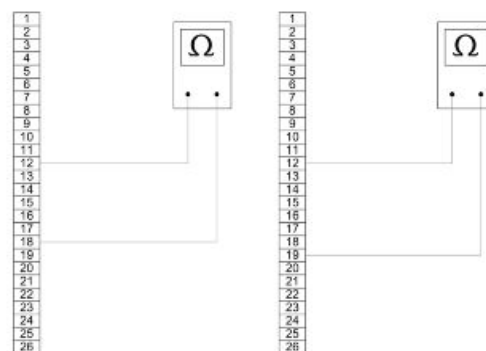

After removing the shield back plate, remove the electrical connection from the aerial as shown in the photograph.



Remove the protective base from the connector.



With the ignition key switch at ON check there is battery voltage between the Red-White and Black cables

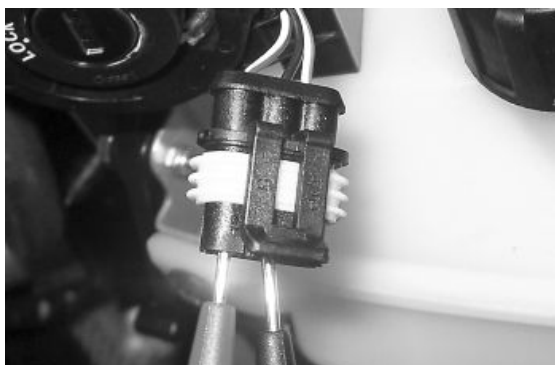

With MIU connector disconnected, check the continuity between the Orange-White cable and pin 7 of the interface wiring .

Specific tooling

020481Y Control unit interface wiring

020331Y Digital multimeter

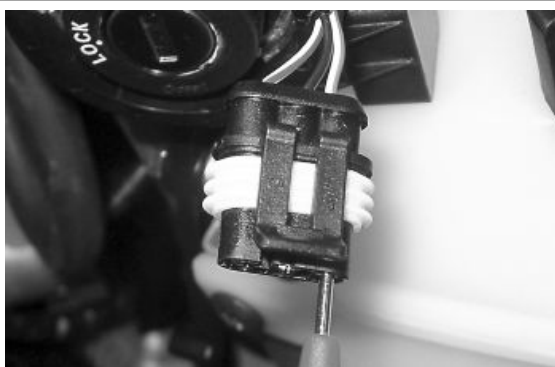

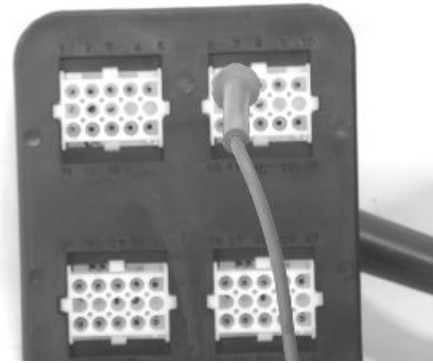

Virgin circuit

When the ignition system is not encrypted, any key will start the engine but limited to 2000 rpm. The keys can only be recognised if the control unit has been programmed properly.

The data storage procedure for a previously un-programmed control unit provides for the recognition of the red key (master key) as the first key to be stored to memory: this becomes particularly important because it is the only key that enables the control unit to be wiped clean and reprogrammed for the memorisation of the service keys.

The master and service keys must be used to code the system as follows:

- Insert the Master key, turn it to «ON» and keep this position for two seconds (lower and upper limits 1 to 3 seconds).
- Insert the blue key and set to «ON» for 2 seconds.
- If you have copies of the key, repeat the operation with each key.
- Insert the MASTER key again and turn it to «ON» for 2 seconds.

The maximum time to change keys is 10 seconds. A maximum of 7 service keys (blue) can be programmed at one time.

It is essential to adhere to the times and the procedure. If you do not, start again from the beginning.

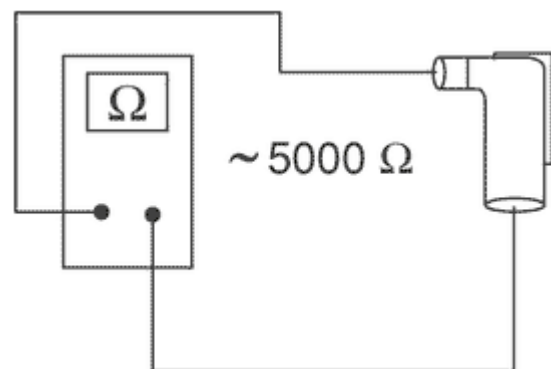

Once the system has been programmed, master key transponder, decoder and control unit are strictly matched.

With this link established, it is now possible to encode new service keys, in the event of losses, replacements, etc.

Each new programming deletes the previous one so, in order to add or eliminate keys, you must repeat the procedure using all the keys you intend to keep using.

If a service key should become un-coded, the efficiency of the high voltage circuit shielding must be thoroughly inspected: In any case it is advisable to use resistive spark plugs.

Characteristic

Shielded cap resistance

~ 5000 Ω .

Diagnostic codes

The immobiliser system is tested each time the ignition-key switch is turned from OFF to ON. During this diagnosis phase a number of control unit statuses can be seen and various light codes displayed. Regardless of the code transmitted, if at the end of the diagnosis the led remains off permanently, the ignition is enabled. If, however, the led remains on permanently, it means the ignition is inhibited:

1. Previously unused control unit - key inserted: a single 2 second flash is displayed, after which the LED remains off permanently. The keys can be stored to memory, the vehicle can be started but with a limitation imposed on the number of revs.

2. Previously unused control unit - transponder absent or cannot be used: The LED is per-

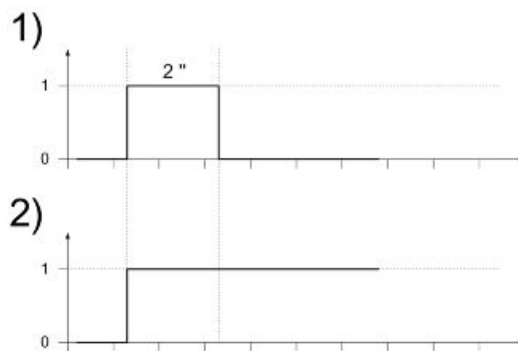

manently ON; in this condition, no operations are possible, including starting of the vehicle.

3. Programmed control unit - the service key in (normal condition of use): a single 0.7-second flash is displayed, after which the LED remains off steadily. The engine can be started.

4. Programmed control unit - Master key in: a 0.7 sec. flash is displayed followed by the LED remaining off for 2 sec. and then by short 0.46 sec. flashes the same number of times as there are keys stored in the memory including the Master key. When the diagnosis has been completed, the LED remains permanently OFF. The engine can be started.

5. Programmed control unit - fault detected: a light code is displayed according to the fault detected, after which the LED remains on steadily. The engine cannot be started. The codes that can be transmitted are:

- Code 1 flash
- 2-flash code
- 3-flash code

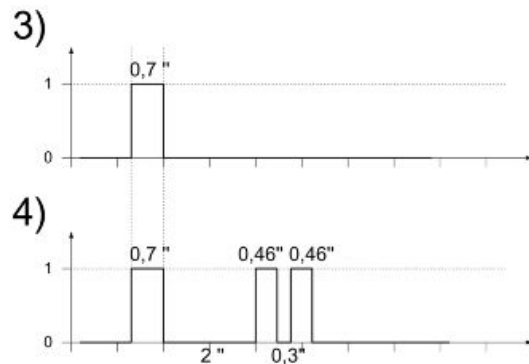

Diagnostic code - 1 flash

The one-flash code indicates a system where the serial line is not present or is not detected. Check the Immobilizer aerial wiring and change it if necessary.

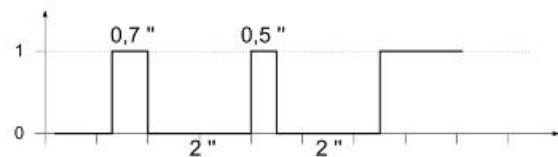

Diagnostic code - 2 flashes

A two-flash code shows a system where the control unit does not show the transponder signal. This might depend on the inefficiency of the immobiliser aerial or the transponder.

Turn the switch to ON using several keys: if the code is repeated even with the Master key, check the aerial wiring and change it if necessary. If this is not the case, replace the defective key and/or reprogram the control unit. Replace the control unit if the problem continues.

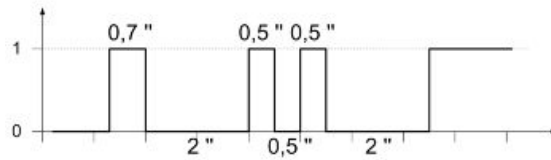

Diagnostic code - 3 flashes

A three-flash code indicates a system where the control unit does not recognise the key. Turn the switch to ON using several keys: if the error code is repeated even with the Master key, replace the control unit. If this is not the case, perform a re-programming.

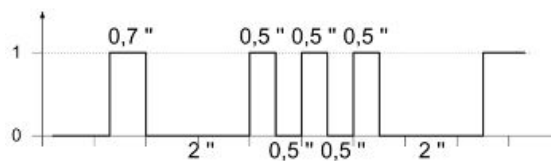

Battery recharge circuit

The recharge system is provided with a three phase alternator with permanent flywheel.

The alternator is directly connected to the voltage regulator.

This, in its turn, is connected directly to the ground and the battery positive terminal passing through the 30A protective fuse.

The three- phase generator provides good recharge power and at low revs, a good compromise is achieved between generated power and idle stability.

Stator check

Stator winding check-up

WARNING

THIS CHECK-UP CAN BE MADE WITH THE STATOR PROPERLY INSTALLED.

- 1) Lift the saddle and remove the helmet compartment.
- 2) Disconnect the connector between stator and regulator with the three yellow cables as shown in the photograph.

- 3) Measure the resistance between each of the yellow terminals and the other two.

Electric characteristic

Resistance:

0.2 - 1 Ω

- 4) Check that there is insulation between the each yellow cable and the ground.
5) If values are incorrect, replace the stator.

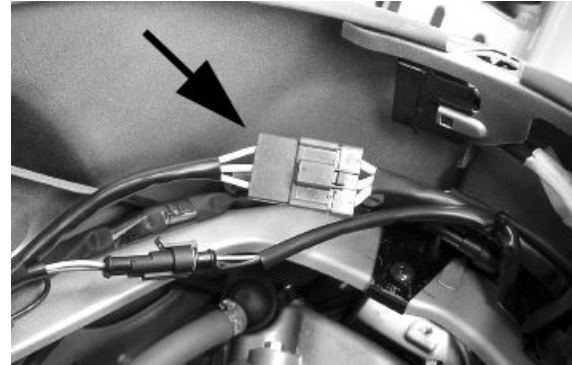

Recharge system voltage check

Look for any leakage

- 1) Access the battery by removing the cover in the footrest.
- 2) Check that the battery does not show signs of losing fluid before checking the output voltage.
- 3) Turn the ignition key to position OFF, connect the terminals of the tester between the negative pole (-) of the battery and the black cable and only then disconnect the black cable from the negative pole (-) of the battery.
- 4) With the ignition key always at OFF, the reading indicated by the ammeter must be ≤ 0.5 mA.

Check the charging current

WARNING

BEFORE CARRYING OUT THE CHECK, MAKE SURE THAT THE BATTERY IS IN GOOD WORKING ORDER.

- 1) Place the vehicle on its centre stand
- 2) With the battery correctly connected to the circuit, place the tester terminals between the battery terminals..
- 3) Start the engine, ensure that the lights are all out, increase the engine speed and at the same time measure the voltage.

Electric characteristic

Voltage ranging between 14.0 and 15.0V at 5000 rpm.

Maximum current output check.

- With engine off and panel set to "ON" turn on the lights and let the battery voltage set to 12V.
 - Connect ammeter pliers to the 2 recharge positive poles in output from the regulator.
 - Keep the lights on and start the engine, bring it to normal speed and read the values on the ammeter.
- With an efficient battery a value must be detected: > 20A

- 2) Check key switch contacts.
- 3) Check the contacts of the stop buttons and the starter button.
- 4) With the key switch set to «ON», the brake pulled and the starter button pressed, check if there is voltage between the Orange-White cable of the start-up remote control switch and the ground connection. If there is not, check the cable harnesses.
- 5) Check the start-up remote control switch.
- 6) Check that the Red cable between the battery and the start-up remote control switch is not interrupted. Also check continuity between the latter and the starter motor.
- 7) Check the starter motor ground connection.
- 8) Check that the Orange-Blue cable between the start-up remote control switch and the control unit (pin 24) is not interrupted.
- 9) Check the contacts of the engine stop switch and that the Green-Black cable connecting this switch to the control unit (pin 12) is not interrupted.
- 10) Check the engine stop switch ground connection.

Horn control

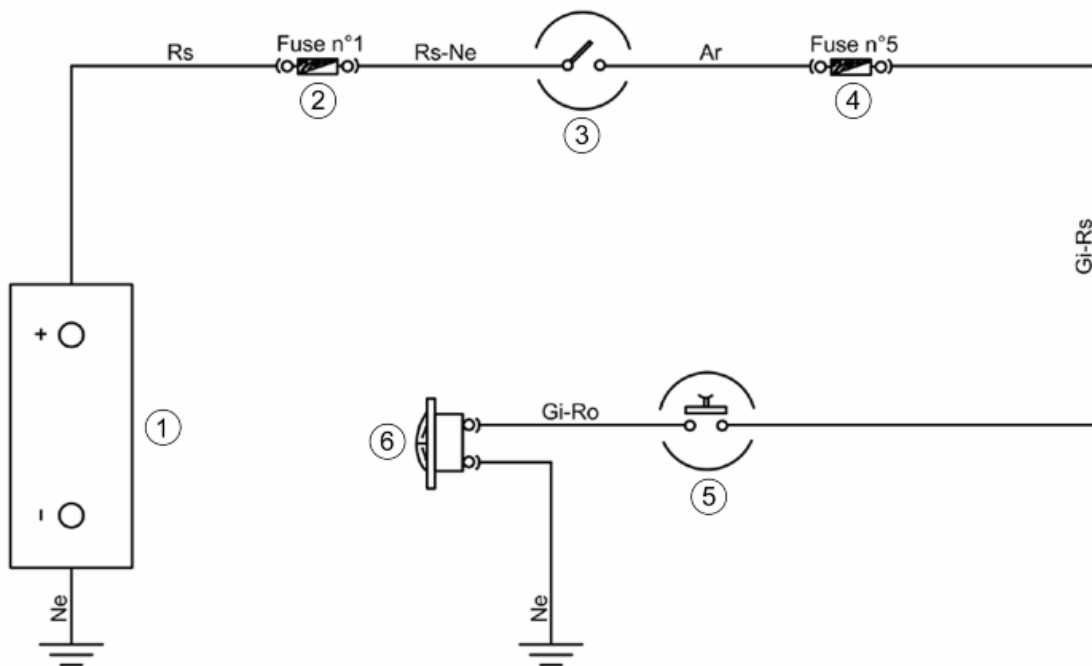

KEY

1. Battery
2. Fuse No. 1
3. Key switch contacts
4. Fuse No. 5

5. Horn button

6. Horn

WARNING

ALL CONTINUITY TESTS MUST BE CARRIED OUT WITH THE CORRESPONDING CONNECTORS DISCONNECTED.

1) Check fuses No. 1 and 5.

2) Check the key switch and horn button contacts.

3) With the key switch set to «ON» and the horn button pressed, check if there is voltage between the Yellow-Pink cable of the horn device and the ground connection. If there is not, check the cable harnesses.

4) Check the horn device ground connection.

Turn signals system check

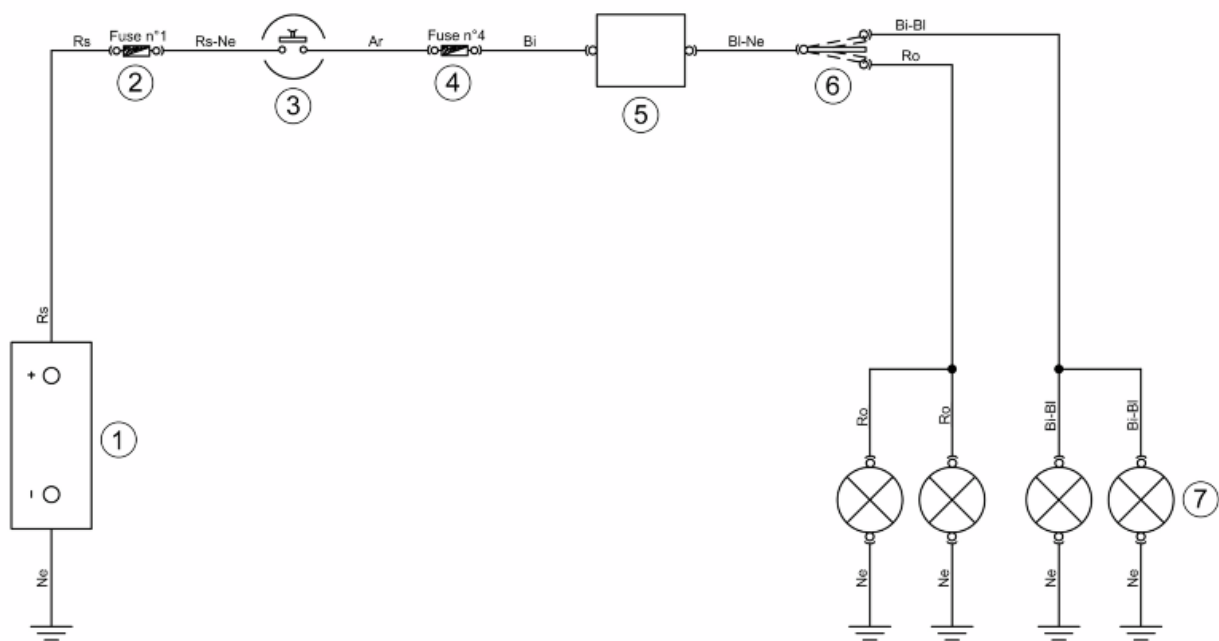

KEY

1. Battery

2. Fuse No. 1

3. Key switch contacts

4. Fuse No. 4

5. Turn indicator control device

6. Turn indicator switch

7. Turn indicator bulbs

WARNING

ALL CONTINUITY TESTS MUST BE CARRIED OUT WITH THE CORRESPONDING CONNECTORS DISCONNECTED.

- 1) Check that bulbs operate properly.
- 2) Check fuses No. 1 and 4.
- 3) Check key switch contacts.
- 4) With the key switch set to «**ON**», check if there is voltage between the Blue-Black cable of the turn indicators switch and the ground connection. If there is not, check the cable harnesses and the connections of the turn indicator control device.
- 5) Check the turn indicator switch contacts.
- 6) With the turn indicator switch pressed to the right, check if there is voltage between the White-Blue cable of the switch and the ground connection. If there is not, check the cable harnesses.
- 7) With the turn indicator switch pressed to the left, check if there is voltage between the Pink cable of the switch and the ground connection. If there is not, check the cable harnesses.
- 8) Check that the cable harnesses of the bulbs and their ground connection are not interrupted.

level indicators**WARNING****ALL CONTINUITY TESTS MUST BE CARRIED OUT WITH THE CORRESPONDING CONNECTORS DISCONNECTED.**

If faults are detected:

- 1) With a multimeter, check resistance values between the White-Green cable and the Black cable of the fuel level transmitter under different conditions.
- 2) If the transmitter operates correctly but the indication on the instrument panel is not exact, check that the cable harnesses between them are not interrupted.

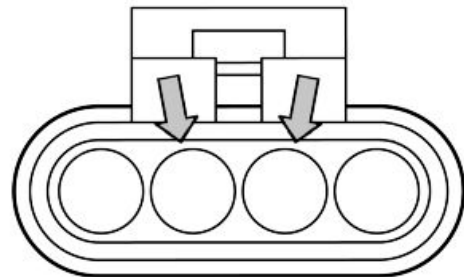
**Electric characteristic****Resistance value when the tank is full**

$\leq 7 \Omega$

Resistance value when the tank is empty

$90 \pm 13/-3 \Omega$

Lights list

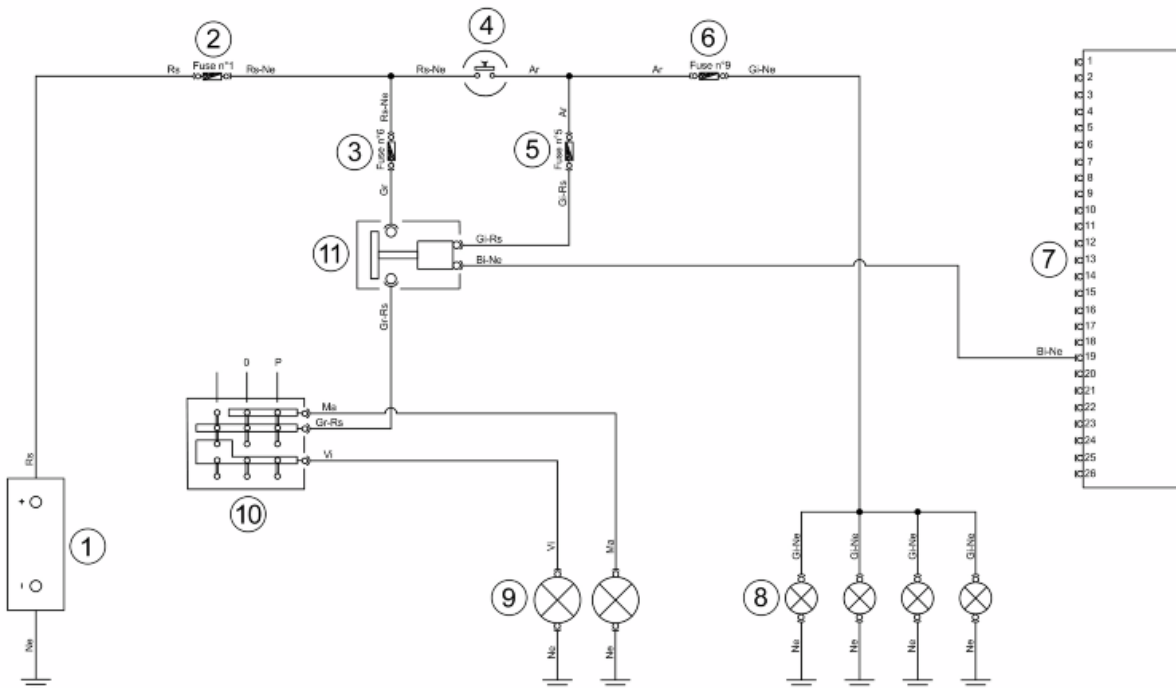

KEY

1. Battery
2. Fuse No. 1
3. Fuse No. 6
4. Key switch contacts
5. Fuse No. 5
6. Fuse No. 9
7. Electronic control unit
8. Tail lights and license plate light bulbs
9. Low-/high-beam twin filament bulb
10. Light switch
11. Headlight remote control

WARNING

ALL CONTINUITY TESTS MUST BE CARRIED OUT WITH THE CORRESPONDING CONNECTORS DISCONNECTED.

TAIL LIGHTS AND LICENSE PLATE LIGHT LINE

- 1) Check that bulbs operate properly.
- 2) Check fuses No. 1 and 9.
- 3) Check key switch contacts.
- 4) Check if there is voltage between the Yellow-Black cable of fuse No. 9 and the ground connection. If there is not, check the cable harnesses.

5) Check that the cable harnesses of the bulbs and their ground connection are not interrupted.

HIGH-BEAM /LOW-BEAM LIGHTS LINE

1) Check that bulbs operate properly.

2) Check fuses No. 1; 5 and 6.

3) Check key switch contacts.

4) Check if there is voltage between the Grey cable of the headlight remote control and the ground connection. If there is not, check the cable harnesses.

5) With the key switch set to «ON» and the engine running, check if there is voltage between the Yellow-Red cable of the headlight remote control and the ground connection. If there is not, check the cable harnesses.

6) Check that the White-Black cable connecting the headlight remote control switch and the control unit (pin 19) is not interrupted.

7) Check the headlight remote control switch.

8) Check that the Grey-Red cable of the light switch and the headlight remote control switch is not interrupted.

9) Check the light switch contacts.

10) Check that the cable harnesses of the bulbs and their ground connection are not interrupted.

Fuses

The electrical system is equipped with:

1. six protection fuses «A» located in the glove compartment to the left
2. two fuses «B» located under the helmet compartment under the saddle hinge latch.
3. one fuse «C» located under the helmet compartment on the left fairing.

The chart shows the position and characteristics of the fuses in the vehicle.

CAUTION



BEFORE REPLACING A BLOWN FUSE, FIND AND SOLVE THE FAILURE THAT CAUSED IT TO BLOW. NEVER TRY TO REPLACE THE FUSE WITH ANY OTHER MATERIAL (E.G., A PIECE OF ELECTRIC WIRE).

CAUTION



MODIFICATIONS OR REPAIRS TO THE ELECTRICAL SYSTEM, PERFORMED INCORRECTLY OR WITHOUT STRICT ATTENTION TO THE TECHNICAL SPECIFICATIONS OF

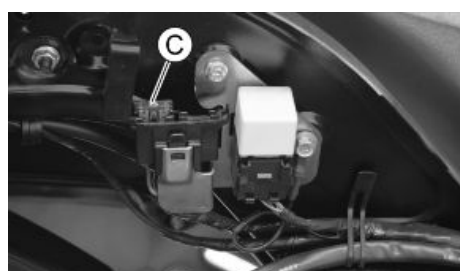
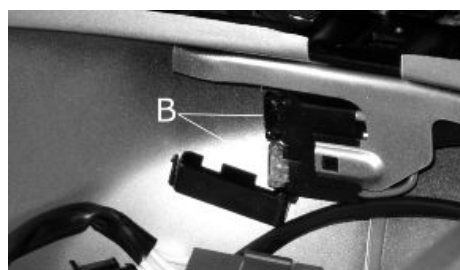
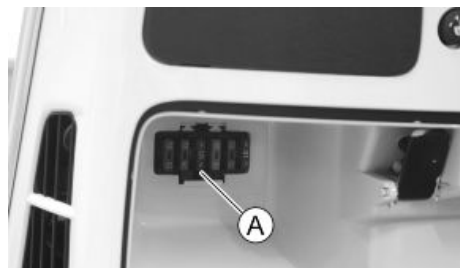

THE SYSTEM, CAN CAUSE ERRORS IN FUNCTIONING AND RISK OF FIRE.

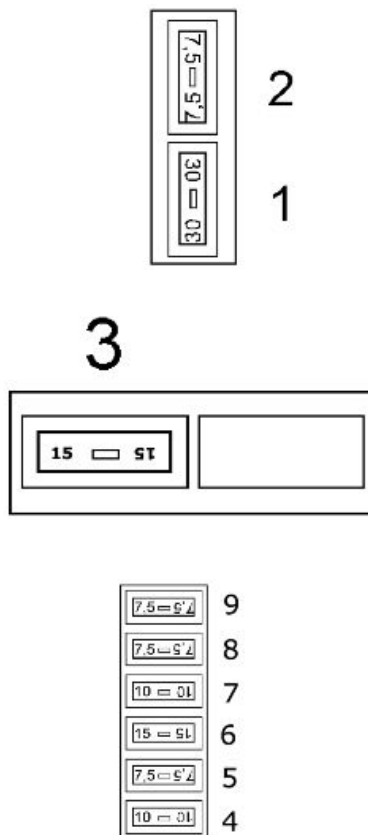

FUSES

	Specification	Desc./Quantity
1	Fuse No. 1	Capacity: 30 A Protected circuits: Battery recharge circuit, fuses No. 6-7. Live: Fuses No. 4 - 5 - 8 - 9
2	Fuse No. 2	Capacity: 7.5 A Protected circuits: Electric fan remote control, injection load remote control, immobilizer aerial, ECU.
3	Fuse No. 3	Capacity: 15A Protected circuits: Injection load (via remote control), ECU.
4	Fuse No. 4	Capacity: 10 A Protected circuits: Turn indicators, pre-installation for anti-theft device, instrument panel.
5	Fuse No. 5	Capacity: 7.5 A Protected circuits: Horn, headlight remote control.
6	Fuse No. 6	Capacity: 15A Protected circuits: Electric fan (via remote control), high-beam and low-beam lights (via remote control). Live: Saddle opening actuator.
7	Fuse No. 7	Capacity: 10 A Protected circuits: Pre-installation for anti-theft device, instrument panel.
8	Fuse No. 8	Capacity: 7.5 A Protected circuits: Start-up circuit, stop light.
9	Fuse No. 9	Capacity: 7.5 A Protected circuits: Tail lights, instrument panel lighting.

Dashboard

- A = Digital clock
- B = Odometer
- C = Speedometer
- D = Injection telltale light
- E = Engine oil pressure warning light
- F = Turn indicators
- G = High-beam warning light
- H = Headlight warning light
- I = Fuel gauge
- L = Low fuel warning light
- M = Coolant temperature gauge
- N = Immobilizer LED



Sealed battery

If the vehicle is provided with a sealed battery, the only maintenance required is the check of its charge and recharging, if necessary.

These operations should be carried out before delivering the vehicle, and on a six-month basis while the vehicle is stored in open circuit.

Besides, upon pre-delivery it is therefore necessary to check the battery charge and recharge it, if required, before storing the vehicle and, afterwards, every six months.

INSTRUCTIONS FOR THE RENEWAL RECHARGE AFTER OPEN-CIRCUIT STORAGE

1) Voltage check up

Before installing the battery on the vehicle, check the open circuit voltage with a regular tester.

- If voltage exceeds 12.60 V, the battery can be installed without any renewal recharge.
- If voltage is below 12.60 V, a renewal recharge is required as explained in 2).

2) Constant voltage battery charge mode

- Constant voltage charge equal to 14.40 ÷ 14.70V
- Initial charge voltage equal to 0.3 ÷ 0.5 for Nominal capacity
- Charge time:

10 to 12 h recommended

Minimum 6 h

Maximum 24 h

3) Constant current battery charge mode

- Charge current equal to 1/10 of the battery rated capacity
- Charge time: Maximum 5 h

Connectors

DIAGNOSIS CONNECTOR

1. Not connected
2. Ground (Black)
3. Electronic control unit (Purple-White)

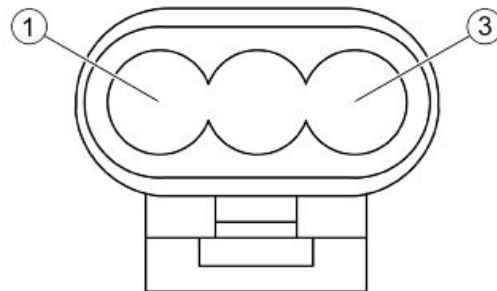

PICK-UP CONNECTOR

1. Positive from control unit (Red)
2. Negative from control unit (Brown)
3. Not connected

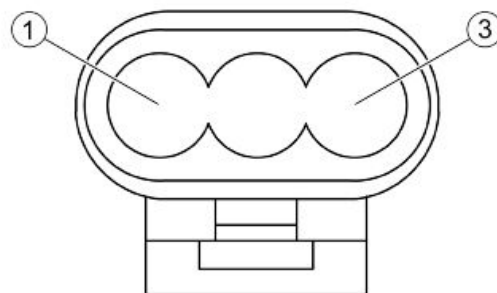

FUEL PUMP CONNECTOR

1. Power via remote control (Black-green)
2. Fuel level indicator (White-green)
3. Ground (Black)
4. Low fuel warning light (Grey-black)

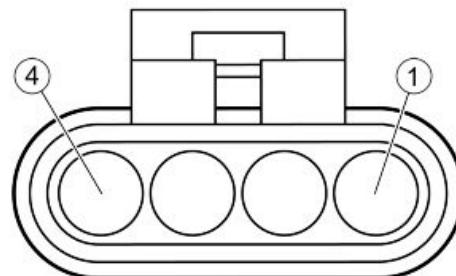

ELECTRONIC CONTROL UNIT CONNECTOR

1. Injection telltale light (Brown-Black)
2. Not connected
3. Not connected
4. Lambda probe negative terminal (White-Green)
5. Live supply (Red-White)
6. Battery powered (Grey-Black)
7. Immobilizer Aerial (Orange-White)
8. Electric fan remote control (Blue-Yellow)
9. Water temperature sensor (Sky blue-Green)
10. Not connected

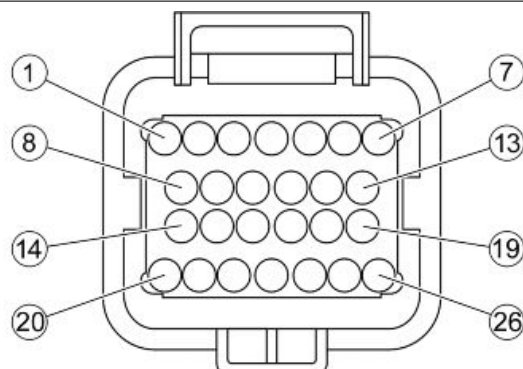

- 11. Lambda probe positive terminal (Sky blue-Black)
- 12. Engine stop switch (Green-Black)
- 13. Engine rpm sensor positive (Red)
- 14. Injector (Red-Yellow)
- 15. Engine rpm sensor negative (Brown)
- 16. Diagnosis (Purple-White)
- 17. Immobilizer warning light (Red-Green)
- 18. Side stand (Grey-Green)
- 19. Low-beam lights automatic turn-on (White-Black)
- 20. Injection load remote control (Black-Purple)
- 21. Not connected
- 22. HV coil (Pink-Black)
- 23. Not connected
- 24. Start-up enabling switch (Orange-Blue)
- 25. Not connected
- 26. Ground (Black)

ENGINE TEMPERATURE SENSOR CONNECTOR

- 1. Ground (Grey-Green)
- 2. Instrument panel (Green-Yellow)
- 3. Electronic control unit (Sky Blue-Green)
- 4. Ground (Black)

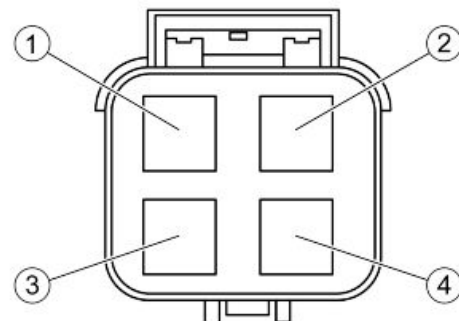

INJECTOR CONNECTOR

- 1. Power via remote control (Black-Green)
- 2. Electronic control unit (Red-Yellow)

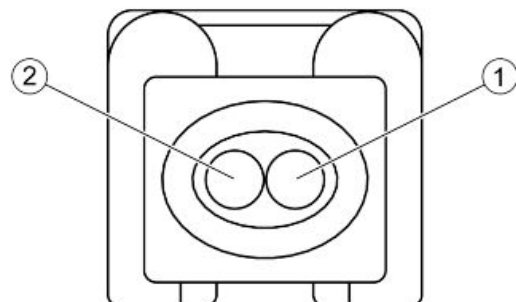

LAMBDA PROBE CONNECTOR

1. Positive from control unit (Sky blue-Black)
2. Negative from control unit (White-Green)

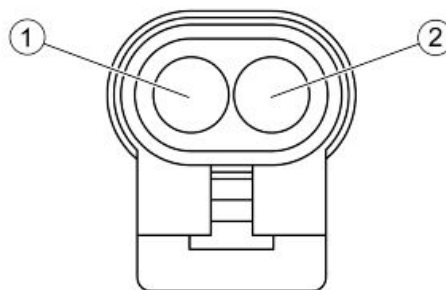
**VOLTAGE REGULATOR CONNECTOR**

1. +Battery (Red-Black)
2. Ground (Black)
3. Battery positive (Red-Black)
4. Ground (Black)

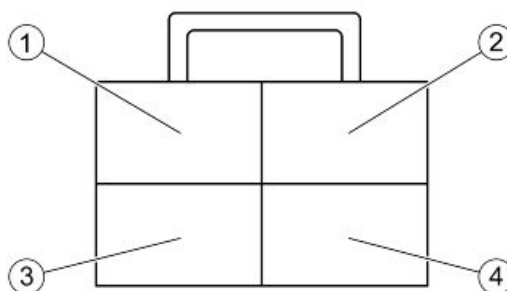
**INSTRUMENT PANEL CONNECTOR «A»**

1. Fuel level indicator (White-Green)
2. High-beam warning light (Purple)
3. Left arrows warning light (Pink)
4. Right arrows warning light (White-Blue)
5. Power permanent supply (White)
6. Oil pressure sensor (Pink-White)

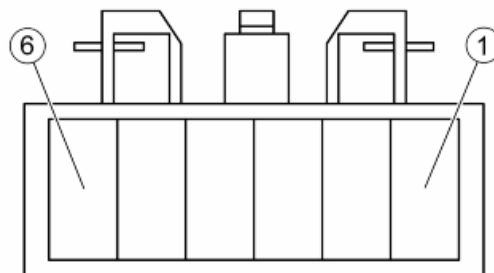
**INSTRUMENT PANEL CONNECTOR «B»**

1. Ground (Black)
2. Injection telltale light (Brown-Black)
3. Low fuel warning light (Grey-Black)
4. Water temperature (Green-Yellow)

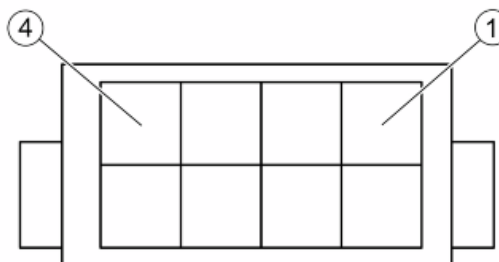

INSTRUMENT PANEL CONNECTOR «C»

1. Immobilizer warning light (Red-Green)
2. Battery powered (Red-Blue)
3. Lighting (Yellow-Black)
4. Power permanent supply (White)

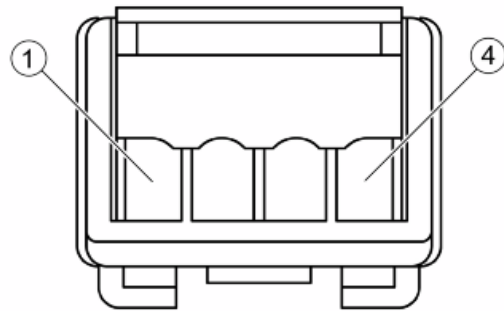

HV COIL CONNECTOR

1. Power via remote control (Black-Green)
2. Electronic control unit (Pink-Black)

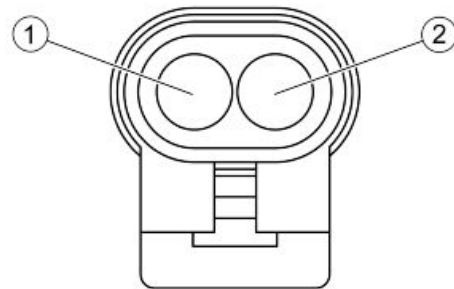

ANTI-THEFT DEVICE PRE-INSTALLATION CONNECTOR

1. Ground (Black)
2. Right arrows (White-Blue)
3. Left arrows (Pink)
4. Battery powered (Red-Blue)
5. Power permanent supply (White)
6. Helmet compartment button pre-installation (Blue-Black)
7. Not connected
8. Not connected

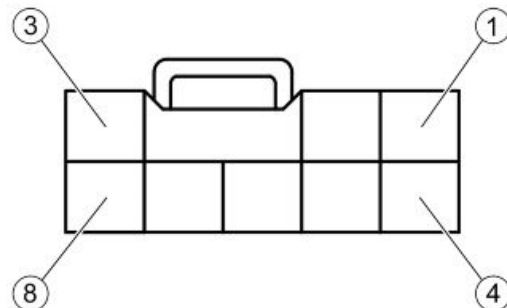

IMMOBILIZER AERIAL CONNECTOR

1. Live supply (Red-White)
2. Ground (Black)
3. Electronic control unit (Orange-White)

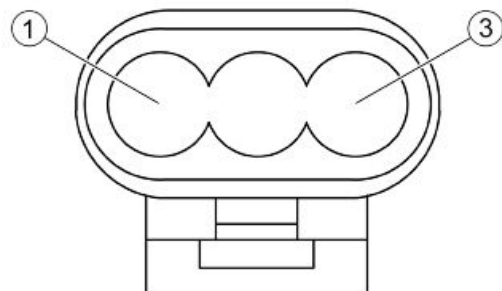

INDEX OF TOPICS

ENGINE FROM VEHICLE

ENG VE

This section describes the operations to carry out when removing the engine from the scooter.

Exhaust assy. Removal

- Remove the right and left fairings and the spoiler terminals.
- Remove the Lambda probe from its support and disconnect it.

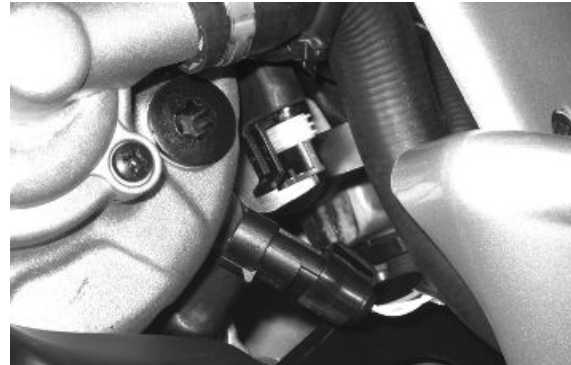

Remove the clamp holding the lambda probe cable to the coolant pipe indicated in the photograph

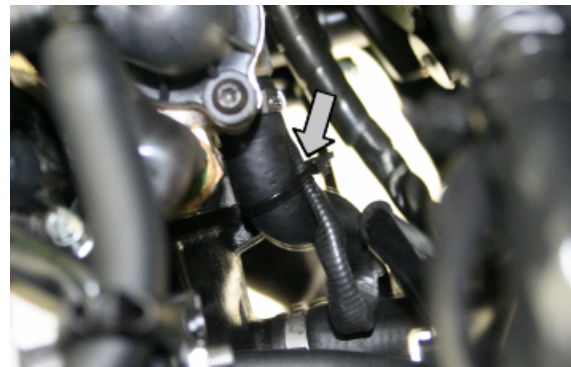

- Undo the two exhaust manifold fixings on the head. To unscrew the nuts that fix the muffler flange to the head properly, use a jointed wrench that allows, according to the travel direction, to get also at the right nut. That is difficult to do with a traditional straight wrench.

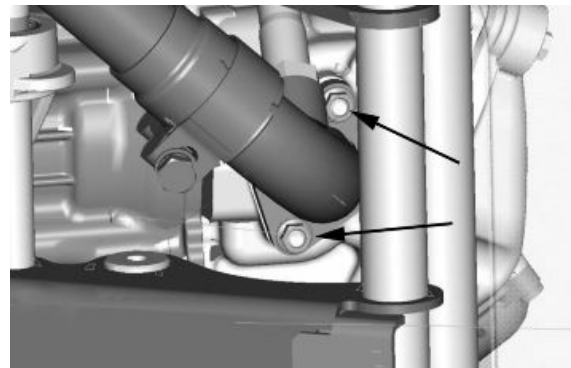

- Undo the three screws that fix the muffler to the support arm.
- Remove the full muffler unit.



Remove the lambda probe from the manifold.



CAUTION: SHOULD IT BE NECESSARY TO REMOVE ONLY THE MUFFLER TIP, ALWAYS REPLACE THE GRAPHITE GASKET BETWEEN STUB AND TIP.

Removal of the engine from the vehicle

CAUTION



SUPPORT THE SCOOTER ADEQUATELY.

- Disconnect the battery.
- Remove the helmet compartment.
- Remove the side fairings and the spoiler terminals.
- Remove the rear brake calliper
- Remove the air cleaner from the housing by unscrewing the three screws indicated in the photograph.

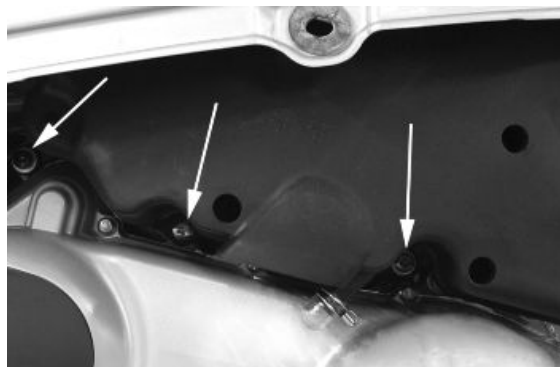

CAUTION



THIS OPERATION MUST BE CARRIED OUT WHEN THE ENGINE IS COLD.

- Remove the clamp from the blow-by pipe and take the pipe out; remove the retainer clamp.
- Remove the clamp indicated in the photograph and disconnect the sleeve connecting it to the throttle body.

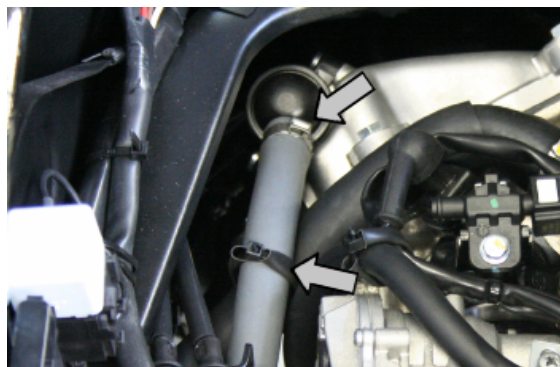



- Get a + 2.5 l container to collect the coolant.
- Remove the coolant inlet pipe to the motor as indicated in the photograph.



- Disconnect the fuel pipe from the injector and remove the screw locking the retainer clamp.
- Disconnect the injector wiring and the throttle body control unit wiring.

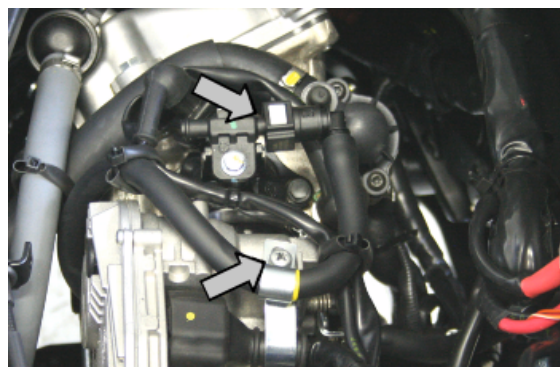

- Disconnect the cable harnesses from the two clamps indicated.

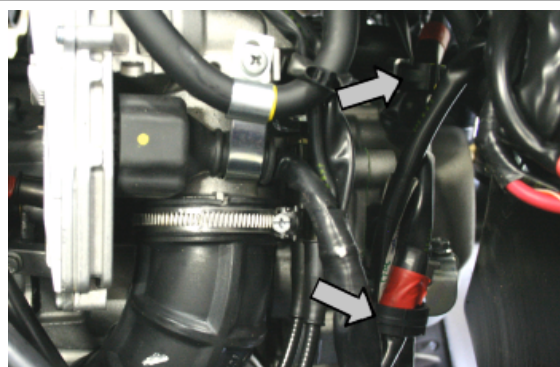

- Remove the coolant outlet pipe from the motor as indicated.

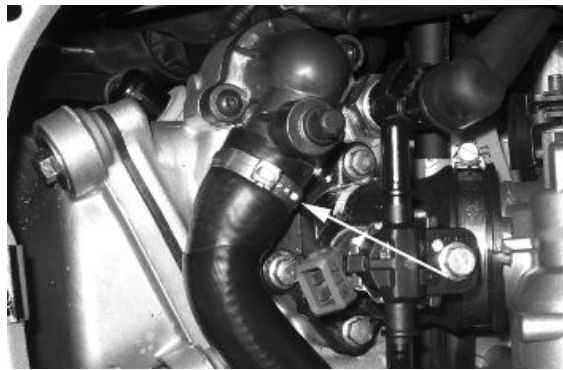

- Remove the spark plug cap.
- Remove the coolant temperature sensor connector indicated in the photo.



- Remove the throttle control cables from the throttle body by undoing the nuts indicated in the photograph.

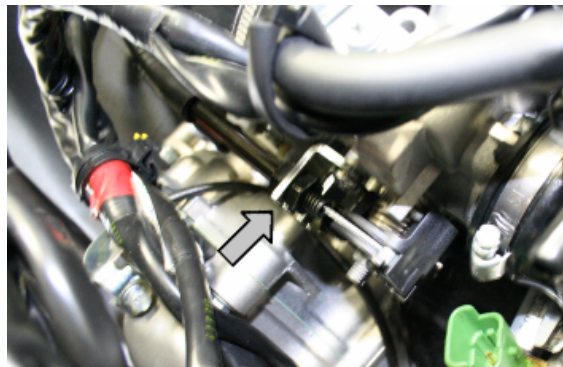

- Loosen the clamp indicated in the photograph and remove the throttle body.

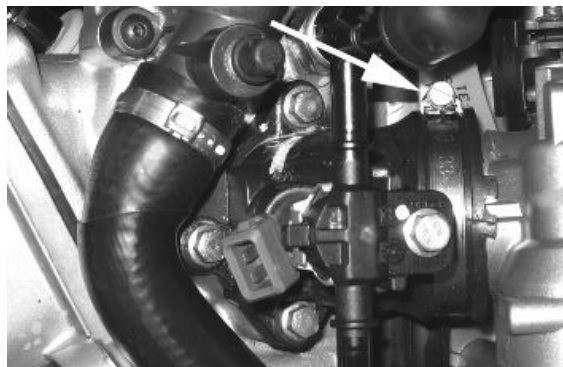

- Remove the clamp retaining the starter motor from the sleeve.

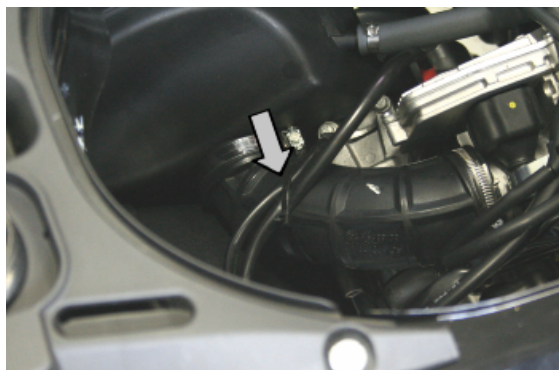

- Remove the positive and negative wiring from the starter motor as shown in the photograph.

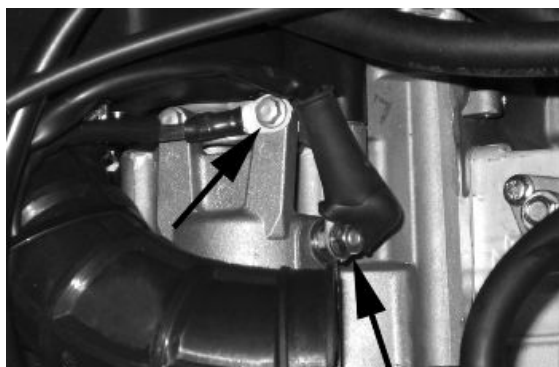

- Disconnect the connectors from the flywheel wiring as shown in the photo.
- Release the cables from the retainer clamps.

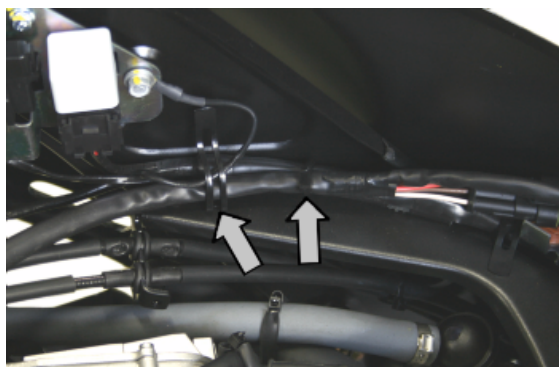

- Remove the four retainers of the rear brake pipes from the crankcase.
- Remove the rear shock absorbers.



- Remove the engine-swinging arm fixing pin by undoing the nut and operating on the head of the pin as shown in the photograph.
- The engine is now free.

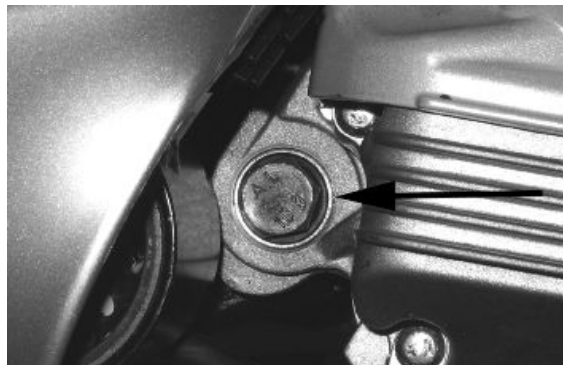
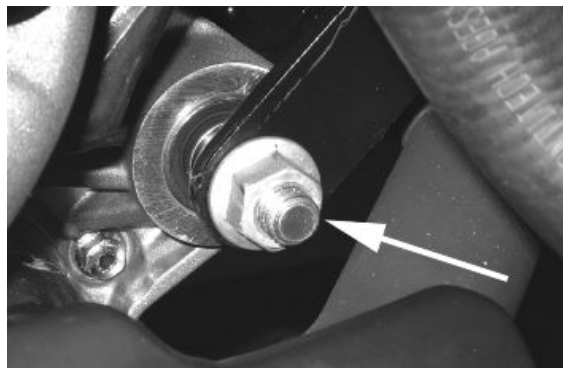

Upon refitting the engine onto the scooter, carry out the removal operations but in reverse order and respect the tightening torques shown in the «Specifications» Chapter.

- Check that there is a small clearance when the valve is in abutment against the set screw.
- Check the engine oil level and if necessary, top it up with the recommended type.
- Fill and bleed the cooling circuit.
- Check accelerator and electrical devices functioning.

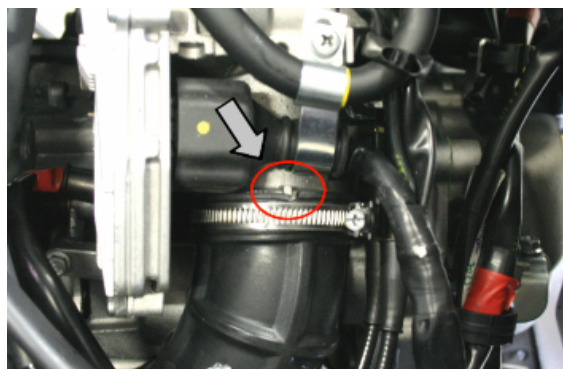

- Pay particular attention to the sleeve, be careful to position the throttle body reference marks as indicated in the photograph.

CAUTION

PAY PARTICULAR ATTENTION TO POSITIONING THE THROTTLE CONTROL TRANSMISSION PROPERLY.

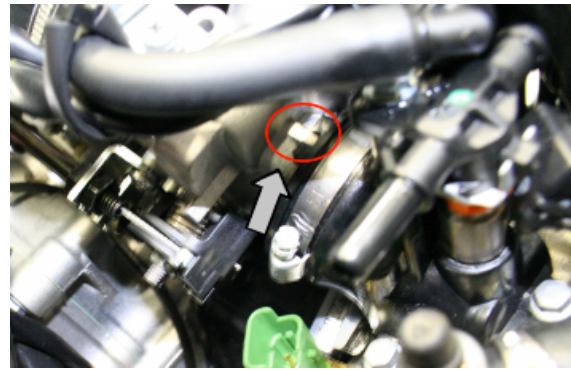

INDEX OF TOPICS

ENGINE

ENG

This section describes the operations to be carried out on the engine and the tools to be used.

Automatic transmission

Transmission cover

- To remove the transmission cover it is necessary to remove the plastic cover first, by inserting a screwdriver in the slotted holes. Using the clutch bell lock wrench shown in the figure, remove the driven pulley shaft locking nut and washer.

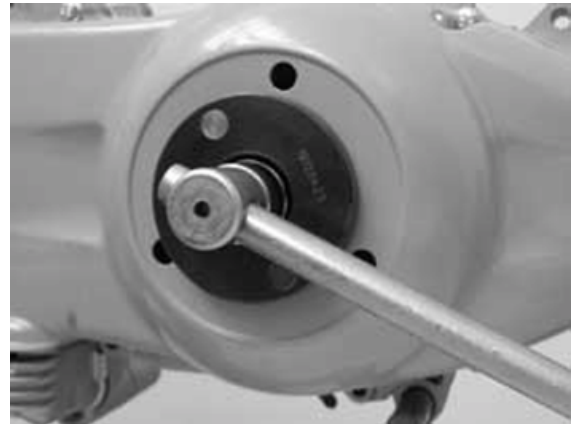

Specific tooling

020423Y driven pulley lock wrench

- Remove the cap/dipstick from the engine oil filling hole.
- Remove the ten screws.
- Remove the transmission cover.

N.B.

WHEN YOU ARE REMOVING THE TRANSMISSION COVER YOU MUST BE CAREFUL NOT TO DROP THE CLUTCH BELL.

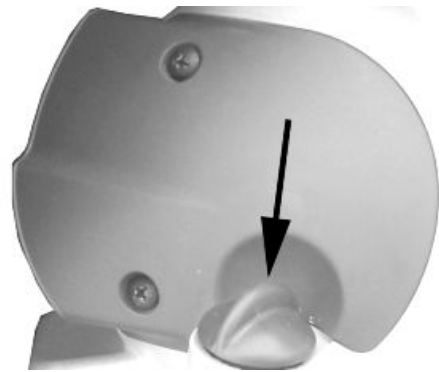

Air duct

Version 250

- Remove the transmission compartment air intake cover shown in the photograph.

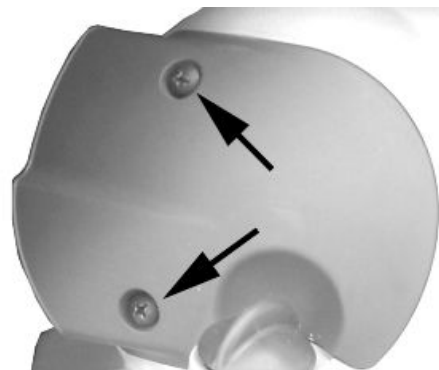

- Remove the five screws on two different levels as well as the small casing.

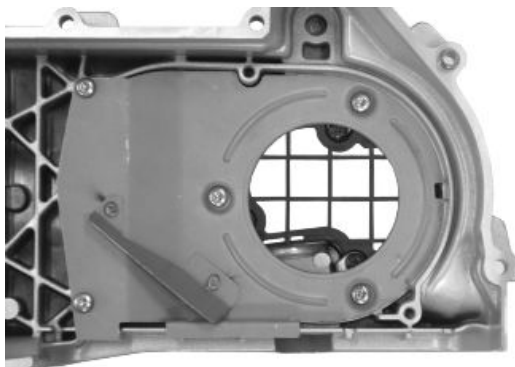

Removing the driven pulley shaft bearing

- Remove the clip from the inside of the cover.
- Remove the bearing from the crankcase by means of:

Specific tooling

020376Y Adaptor handle

020375Y Adaptor 28 x 30 mm

020412Y 15 mm guide

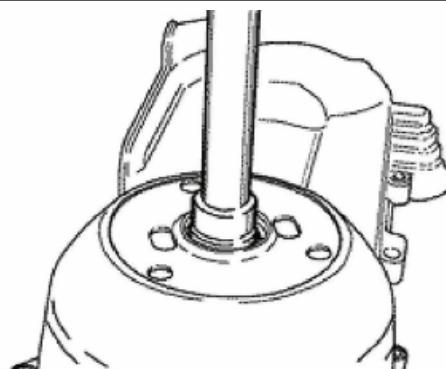

Refitting the driven pulley shaft bearing

- Slightly heat the crankcase from the inside so as not to damage the painted surface.
- Insert the bearing in its seat.
- Refit the seeger ring.

CAUTION

USE AN APPROPRIATE REST SURFACE TO AVOID DAMAGING THE COVER PAINT.

N.B.

ALWAYS REPLACE THE BEARING WITH A NEW ONE UPON REFITTING.

Specific tooling

020376Y Adaptor handle

020357Y 32 x 35 mm adaptor

020412Y 15 mm guide

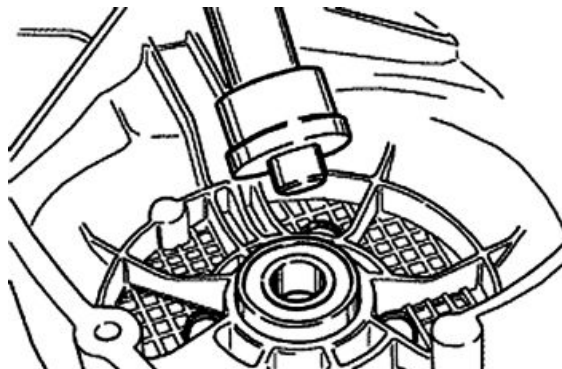

Baffle roller

Plastic roller

- Check that the roller does not show signs of wear and that it turns freely.
- Remove the special clamping screws as indicated in the photograph

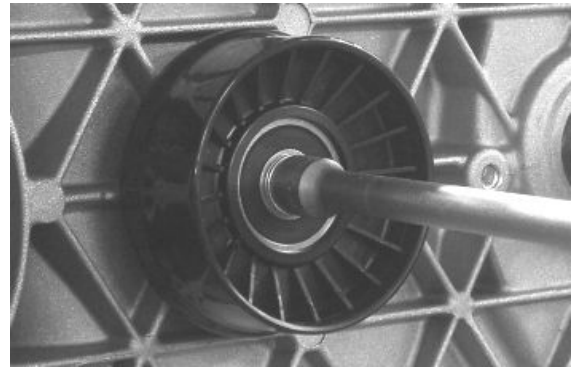

- Check the outside diameter of the roller does not have defects that could jeopardise belt functioning
- For refitting, place the roller with the belt containment edge on the engine crankcase side
- Tighten the wrench to the prescribed torque.



Locking torques (N*m)

Anti-flapping roller 12 - 16

Removing the driven pulley

- Remove the clutch bell housing and the driven pulley assembly.

N.B.

THE UNIT CAN ALSO BE REMOVED WITH THE DRIVING PULLEY MOUNTED.



Inspecting the clutch drum

- Check that the clutch bell is not worn or damaged.
- Measure the clutch bell inside diameter.

Characteristic

Max. value clutch bell

Max. value: \varnothing 134.5 mm

Clutch bell standard value

Standard value: \varnothing 134 - 134.2 mm



Checking the bell working surface eccentricity

- Install the bell on a driven pulley shaft using 2 bearings (inner diameter 15 and 17 mm).
- Lock with the original spacer and nut.
- Place the bell/shaft assembly on the support to check the crankshaft alignment.

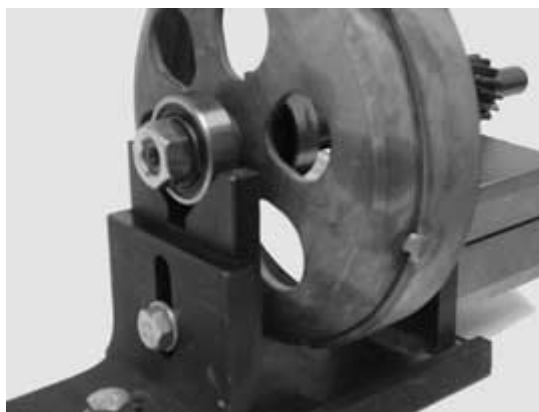

- Using a feeler pin gauge and the magnetic base, measure the bell eccentricity.
- Repeat the measurement in 3 positions (Central, internal, external).
- If faults are found, replace the bell.



Specific tooling

020074Y Support base for checking crankshaft alignment

020335Y Magnetic support for dial gauge

Characteristic

clutch bell inspection: Limit eccentricity.

Admissible limit eccentricity: 0.15 mm

Removing the clutch

Fit the driven pulley spring compressor specific tool with medium length pins screwed in position «C» on the tool internal side.

- Introduce the adapter ring No. 11 with the chamfering facing the inside of the tool.

- Fit the driven pulley unit on the tool with the insertion of the 3 pins in the ventilation holes in the mass holder support.

- Make sure that the clutch is perfectly inserted into the adapter ring before proceeding to loosen/tighten the clutch nut.

- Use the special 46x55 wrench component No. 9 to remove the nut fixing the clutch in place.

- Dismantle the driven pulley components (Clutch and spring with its plastic holder)

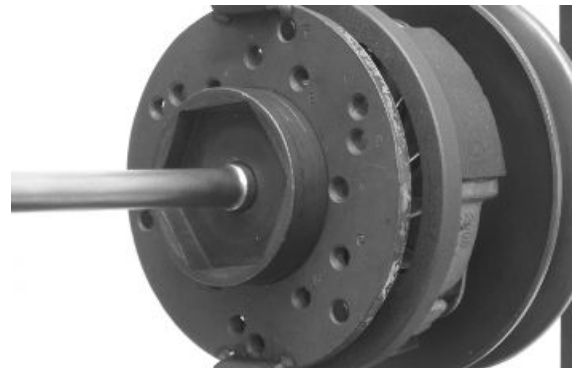

CAUTION

THE TOOL MUST BE FIRMLY FIXED IN THE CLAMP AND THE CENTRAL SCREW MUST BE BROUGHT INTO CONTACT WITH THE TOOL. EXCESSIVE TORQUE CAN CAUSE THE SPECIFIC TOOL TO BUCKLE.

Specific tooling

020444Y011 adapter ring

020444Y009 46x55 Wrench

020444Y Tool for fitting/ removing the driven pulley clutch

Inspecting the clutch

- Check the thickness of the clutch mass friction material.

- The masses must not show traces of lubricants; otherwise, check the driven pulley unit seals.

N.B.

UPON RUNNING-IN, THE MASSES MUST EXHIBIT A CENTRAL CONTACT SURFACE AND MUST NOT BE DIFFERENT FROM ONE ANOTHER. VARIOUS CONDITIONS CAN CAUSE THE CLUTCH TO TEAR.

CAUTION

DO NOT OPEN THE MASSES USING TOOLS TO PREVENT A VARIATION IN THE RETURN SPRING LOAD.



Characteristic

Check minimum thickness

1 mm

Pin retaining collar

- Simultaneously turn and pull the collar manually to remove it.

N.B.**USE TWO SCREWDRIVERS IF YOU HAVE DIFFICULTY.****N.B.****BE CAREFUL NOT TO PUSH THE SCREW DRIVERS IN TOO FAR TO AVOID DAMAGE THAT COULD ENDANGER THE O-RING SEAL.**

- Remove the four torque server pins and pull the pulley halves apart.

**Removing the driven half-pulley bearing**

- Check there are no signs of wear and/or noisiness; - Replace with a new one if there are.
- Remove the retaining ring using two flat blade screwdrivers.
- Support the pulley bushing adequately from the threaded side using a wooden surface.
- Using a hammer and pin, knock the ball bearing out as shown in the figure.

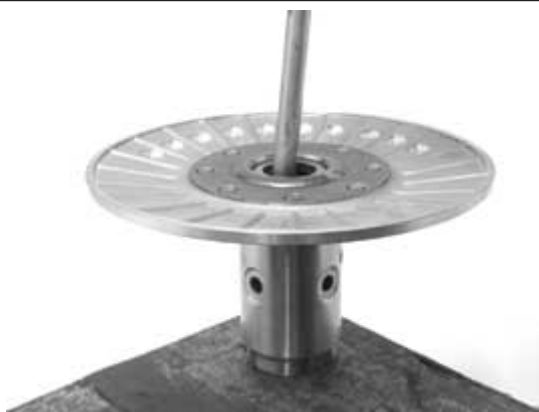

- Support the pulley properly using the bell as shown in the figure.

Specific tooling

001467Y035 Belle for OD 47-mm bearings



- Remove the roller bearing using the modular punch.

Specific tooling

020376Y Adaptor handle

020456Y Ø 24 mm adaptor

020363Y 20 mm guide

Inspecting the driven fixed half-pulley

- Measure the outside diameter of the pulley bushing.
- Check the contact surface with the belt to make sure there are no flaws.
- Check the riveted joints are functional.
- Check the evenness of the belt contact surface.

Characteristic

Half-pulley minimum diameter

Minimum admissible diameter Ø 40.96 mm

Half-pulley standard diameter

Standard diameter: Ø 40.985 mm

Wear limit

0.3 mm



Inspecting the driven sliding half-pulley

- Remove the two internal grommets and the two O-rings.
- Measure the movable half-pulley bushing inside diameter.
- Check the contact surface with the belt to make sure there are no flaws.
- Check the riveted joints are functional.
- Check the evenness of the belt faying surface.



MOVABLE DRIVEN HALF-PULLEY DIMENSIONS

Specification	Desc./Quantity
Wear limit	0.3 mm
standard diameter	Diameter 41.000 - 41.035 mm
maximum allowable diameter	Ø 41.08 mm

Refitting the driven half-pulley bearing

- Support the pulley bushing adequately from the threaded side using a wooden surface.
- Fit a new roller sleeve as in the figure.
- For the fitting of the new ball bearing, follow the example in the figure using a modular punch.

Fit the snap ring

WARNING

N.B.

FIT THE BALL BEARING WITH THE VISIBLE SHIELD

Specific tooling

020376Y Adaptor handle

020375Y Adaptor 28 x 30 mm

020424Y Driven pulley roller casing fitting punch





Refitting the driven pulley

- Insert the new oil guards and O-rings on the movable half-pulley.
- Lightly grease the O-rings «A» shown in the figure.
- Fit the half-pulley over the bushing using the specific tool.
- Check that the pins are not worn and proceed to refitting them in their slots.
- Refit the torque server closure collar.
- Using a curved-spout grease gun, lubricate the driven pulley unit with approximately 6 gr. of grease. Apply the grease through one of the holes in the bushing until it comes out through the hole on the opposite side. This operation is necessary to avoid the presence of grease beyond the O-rings.

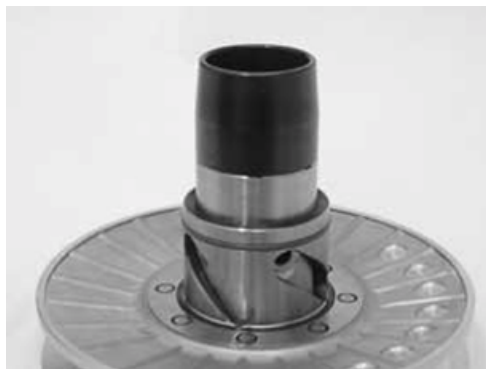
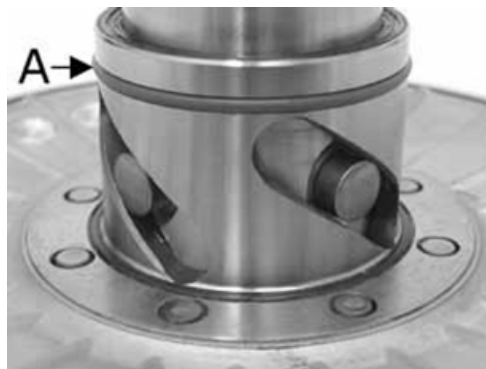

N.B.

THE TORQUE SERVER CAN BE GREASED WHETHER WITH BEARINGS FITTED OR WHEN THEY ARE BEING REPLACED; UNDERTAKING THE OPERATION WHEN THE BEARINGS ARE BEING SERVICED MIGHT BE EASIER.

Specific tooling

020263Y Sheath for driven pulley fitting

Recommended products

AGIP GREASE SM 2 Grease for the tone wheel revolving ring

Soap-based lithium grease containing NLGI 2 Molybdenum disulphide; ISO-L-XBCHB2, DIN KF2K-20

Inspecting the clutch spring

- Measure the length of the spring, while it is relaxed.

**Characteristic
Standard length**

123 mm

acceptable limit after use:

118 mm

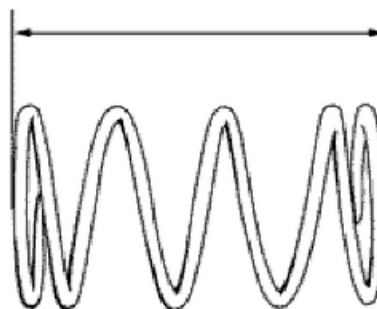

Refitting the clutch

- Support the driven pulley spring compressor appropriate tool with the control screw in vertical axis.
- Arrange the tool with the medium length pins screwed in position "C" on the inside.
- Introduce the adapter ring No. 11 with the chamfering facing upwards.
- Insert the clutch on the adapter ring.
- Lubricate the end of the spring that abuts against the servo-system closing collar.
- Insert the spring with its plastic holder in contact with the clutch.
- Insert the driving belt into the pulley unit according to their direction of rotation.
- Insert the pulley unit with the belt into the tool.
- Slightly preload the spring.
- Make sure that the clutch is perfectly inserted into the adapter ring before proceeding to tighten the clutch nut.
- Place the tool in the clamp with the control screw on the horizontal axis.
- Fully preload the spring.



- Apply the clutch fixing nut and tighten it to the prescribed torque using the special 46x55 wrench.
- Loosen the tool clamp and insert the belt according to its direction of rotation.
- Lock the driven pulley again using the specific tool.
- Preload the clutch return spring with a traction/rotation combined action and place the belt in the smaller diameter rolling position.
- Remove the driven pulley /belt unit from the tool.

N.B.

DURING THE SPRING PRELOADING PHASE, BE CAREFUL NOT TO DAMAGE THE PLASTIC SPRING STOP AND THE BUSHING THREADING.

N.B.

FOR DESIGN REASONS, THE NUT IS SLIGHTLY ASYMMETRIC; THE FLATTEST SURFACE SHOULD BE MOUNTED IN CONTACT WITH THE CLUTCH.

Specific tooling

020444Y Tool for fitting/ removing the driven pulley clutch

020444Y011 adapter ring

020444Y009 46x55 Wrench

Locking torques (N*m)

Clutch unit nut on driven pulley 45 ÷ 50

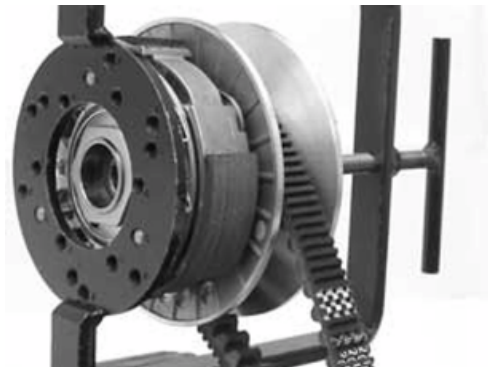
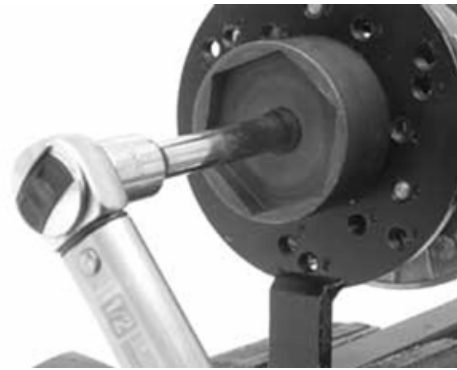

Refitting the driven pulley

- Refit the clutch bell.

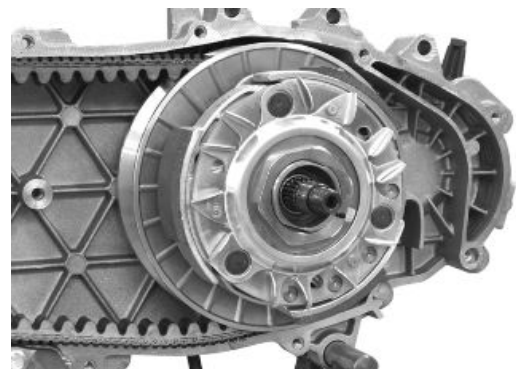

Drive-belt

- Check that the driving belt is not damaged.
- Check the width of the belt.

Characteristic

Driving belt - minimum width

19.5 mm

Driving belt - standard width

21.3 ± 0.2 mm

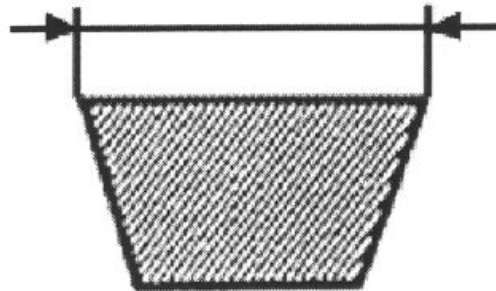

During the wear checks in the scheduled servicing programme, you are advised to check the rim bottom of the tothing does not show signs of incisions or cracking (see figure): The rim bottom of the tooth must not have incisions or cracking; if it does, replace the belt.

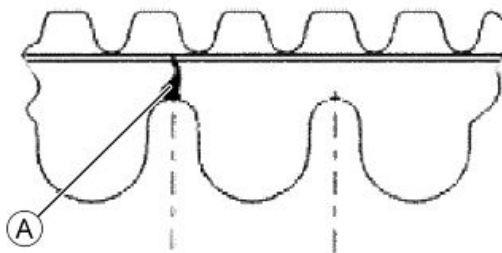

Removing the driving pulley

- Turn the crankshaft until the ropes of the pulley are on a horizontal axis



- Insert the adaptor sleeve of the appropriate tool in the hole shown in the photograph

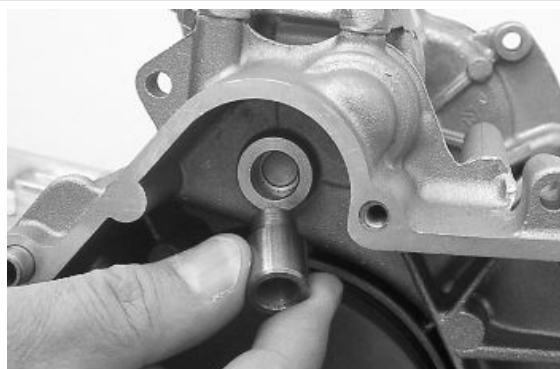

- Insert the tool in the hollows and apply the retention ring
- Bring in the ring's clamping screws while keeping the tool to support the pulley

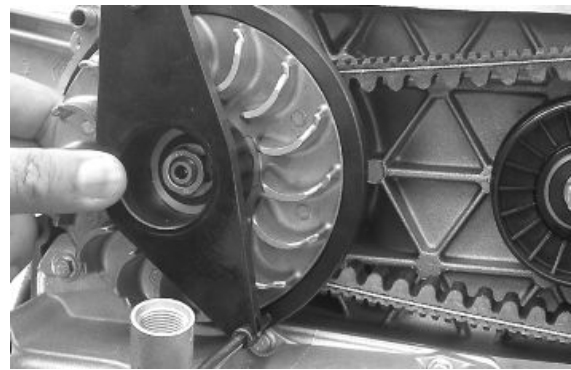

Specific tooling

020626Y Driving pulley lock wrench

- Remove the fixing nut and the washer
- Remove the stationary drive pulley half.

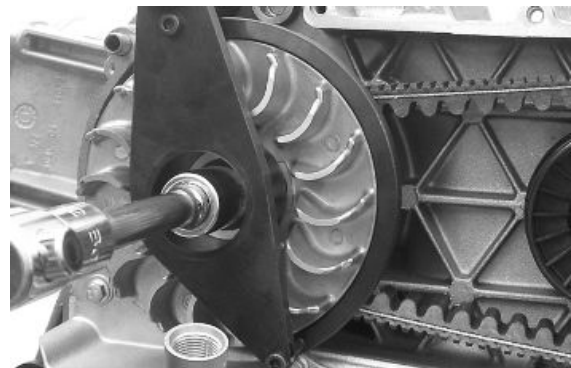

Inspecting the rollers case

- Check that the internal bushing shown in the figure is not abnormally worn and measure its inside diameter.
- Measure outside diameter B of the pulley sliding bushing shown in the figure.
- Check that the rollers are not damaged or worn.
- Check the guide shoes for the variator back-plate are not worn.
- Check the wear of the roller housings and of the belt contact surfaces on both pulley halves.
- Check that stationary driving pulley does not show signs of abnormal wear on the grooved edge and on the surface in contact with the belt.
- Check that the O-ring is not pushed out of shape.



CAUTION

DO NOT LUBRICATE OR CLEAN SINTERED BUSHINGS

Characteristic

Movable driving half-pulley bushing: Standard Diameter

26.000 - 26.021 mm

Movable driving half-pulley bushing: Maximum allowable diameter

Ø 26.12 mm

Sliding bushing: Standard Diameter

Ø 25.959 ÷ 25.98 mm

Sliding bushing: Minimum admissible diameter

Ø 25.95 mm

Roller: Standard Diameter

Diameter 20.5 - 20.7 mm

Roller: Minimum diameter permitted

Ø 20 mm



Refitting the driving pulley

- Preassemble the movable half-pulley with the roller contrast plate by putting the rollers in their housings with the larger support surface touching the pulley according to the direction of rotation.
- Check that the roller contact plate does not have flaws and is not damaged on the grooved edge.
- Mount the complete bushing unit on the driving shaft.
- Fit the driven pulley/Clutch/belt unit on the engine.

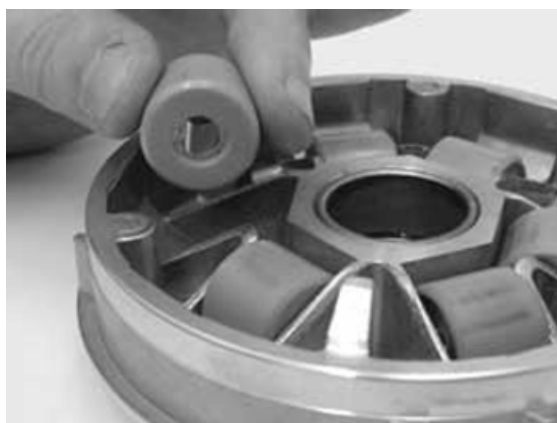



- Fit the steel shim in contact with the bushing and the stationary drive pulley.
- Install the appropriate tool as described in the removal phase.
- Tighten the nut with washer to the prescribed torque.

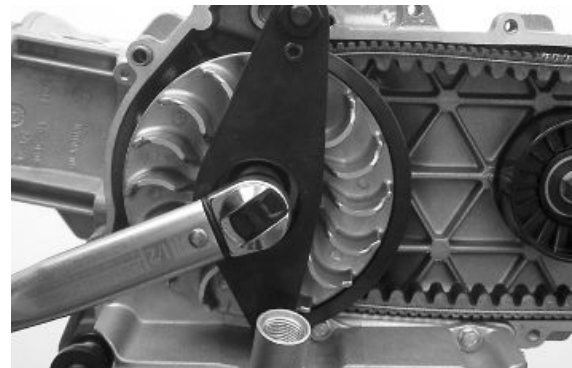

Specific tooling

020626Y Driving pulley lock wrench

Locking torques (N*m)

Drive pulley nut 75 ÷ 83

Refitting the transmission cover

- Check the presence of the 2 centring dowels and the correct installation of the sealing gasket for the oil sump on the transmission cover.
- Replace the cover tightening the 10 screws at the specified torque.
- Refit the oil loading cap/bar.
- refit the steel washer and the driven pulley nut.
- Tighten the nut to the prescribed torque using the lock wrench and the torque wrench tools.
- Replace the plastic cover.

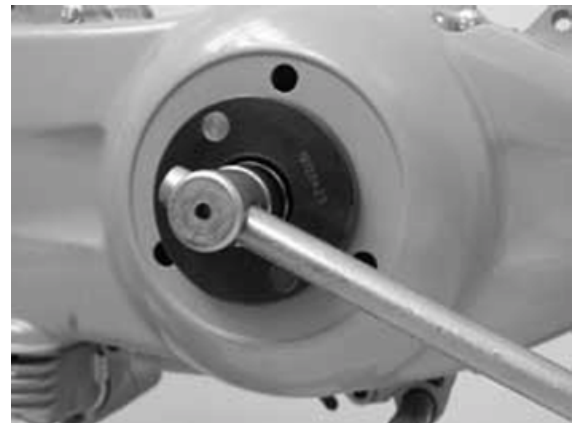

Specific tooling

020423Y driven pulley lock wrench

Locking torques (N*m)

Transmission cover screws 11 ÷ 13 Driven pulley shaft nut 54 ÷ 60

End gear

Removing the hub cover

- Empty the rear hub through the oil drainage plug.
- Remove the 7 flanged screws indicated in the figure.
- Remove the hub cover and its gasket.

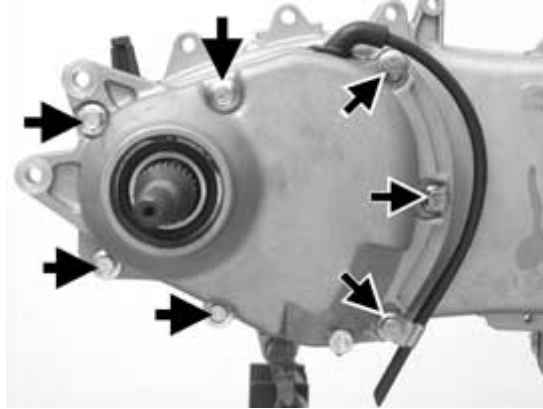

Removing the wheel axle

- Remove the wheel axis complete with gear.
- Remove the intermediate gear.

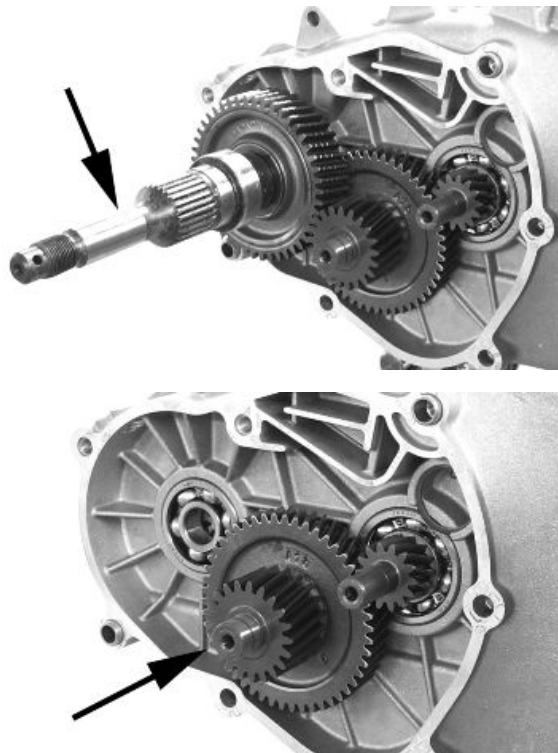

Removing the hub bearings

- Check the state of the bearings being examined (wear, clearance and noisiness). If faults are detected, do the following.
- Use the specific bearing extractor to remove the three 15 mm bearings (2 in the crankcase and 1 in the hub cover).

Specific tooling

001467Y013 Pliers to extract \varnothing 15-mm bearings



Removing the wheel axle bearings

- Take out the clip on the outside of the gearbox cover.
- Support the hub cover and expel the bearing. By means of the appropriate tools, remove the oil guard as in the figure.

Specific tooling

020376Y Adaptor handle

020477Y Adaptor 37 mm

020483Y 30 mm guide

020359Y 42x47-mm adaptor

020489Y Hub cover support stud bolt set



Removing the driven pulley shaft bearing

- As you need to remove the driven pulley shaft, its bearing and oil guard, remove the transmission cover as described above.
- Extract the driven pulley shaft from its bearing.
- Remove the oil guard using a screwdriver, working from inside the bearing and being careful not to damage the housing, make it come out of the belt transmission side.
- Remove the seeger ring shown in the figure. Remove the driven pulley shaft bearing using the modular punch.

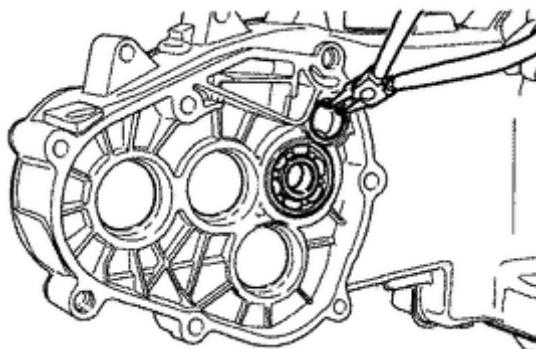

Specific tooling

020376Y Adaptor handle

020375Y Adaptor 28 x 30 mm

020363Y 20 mm guide

Inspecting the hub shaft

- Check the three shafts for wear or distortion of the toothed surfaces, the bearing housings, and the oil seal housings.
- In case of anomalies, replace the damaged components.



Inspecting the hub cover

- Check that the fitting surface is not dented or distorted.
- Check the bearing bearings.
- In case of anomalies, replace the damaged components.

Refitting the wheel axle bearing

- Support the hub cover on a wooden surface.
- Heat the crankcase cover with the specific heat gun.
- Fit the wheel shaft bearing with a modular punch as shown in the figure.
- Fit the seeger ring.
- Fit the oil guard with seal lip towards the inside of the hub and place it flush with the internal surface by means of the appropriate tool used from the 52 mm side.

The 52 mm side of the adaptor must be turned towards the bearing.

Specific tooling

020376Y Adaptor handle

020360Y Adaptor 52 x 55 mm

020483Y 30 mm guide

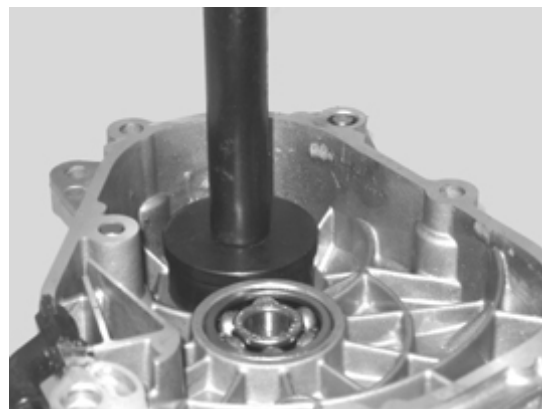

Refitting the hub cover bearings

For the fitting of the hub box bearings the engine crankcase and the cover must be heated with the special heat gun.

- The three 15 mm bearings must be fitted using the appropriate tools.
- The 42-mm side of the adaptor must be turned towards the bearing.

Specific tooling

020150Y Air heater support

020151Y Air heater

020376Y Adaptor handle

020359Y 42x47-mm adaptor

020412Y 15 mm guide

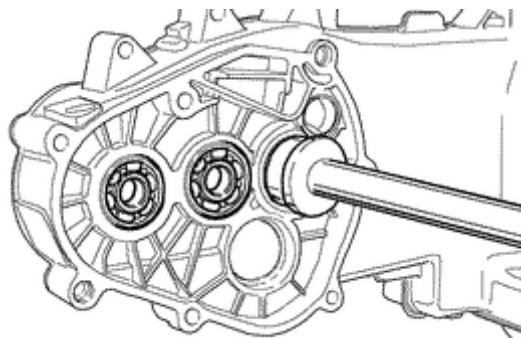

N.B.

TO FIT THE BEARING ON THE COVER, SUPPORT THE COVER WITH THE STUD BOLT SET.

- Refit the driven pulley shaft bearing with a modular punch as shown in the figure.

N.B.

IF THE BEARING HAS AN ASYMMETRICAL BALL RETAINER, PLACE IT SO THAT THE BALLS ARE VISIBLE FROM THE HUB INNER SIDE.

Specific tooling

020376Y Adaptor handle

020359Y 42x47-mm adaptor

020363Y 20 mm guide

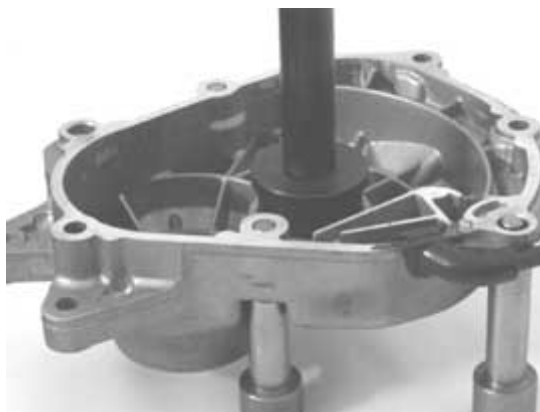

N.B.

WHEN FITTING THE BEARINGS ON THE ENGINE CRANKCASE, SUPPORT THE CRANKCASE PREFERABLY ON A SURFACE TO ALLOW THE BEARINGS TO BE DRIVEN VERTICALLY.

- Refit the seeger ring with the opening facing the bearing and fit a new oil guard flush with the crankcase from the pulley side.

Refitting the hub bearings

- Install the three shafts in the engine crankcase as shown in the figure.



Refitting the gearbox cover

- Fit a new gasket together with the centring dowels.
- Seal the gasket of the breather pipe using black silicone sealant.
- Fit the gearbox cover, making sure the breather pipe is in the correct position.
- Position the shorter screw that can also be recognised from the different colour as shown in the figure.
- Fix the breather tube support by means of the lower screw.
- Fit the remaining screws and tighten the seven screws to the prescribed torque.

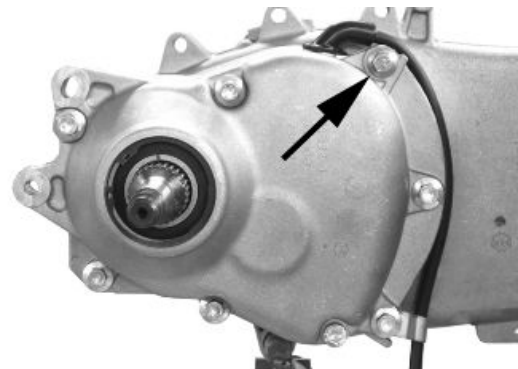
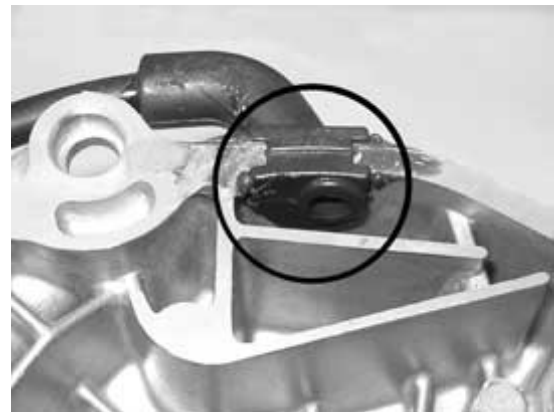

Flywheel cover

Removing the hub cover

- Remove the clip fixing the hose to the cylinder.
- Remove the 10 fixings
- Remove the flywheel cover.

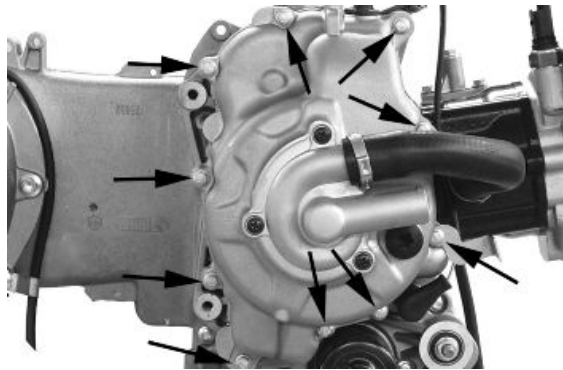

Removing the stator

- Remove the two pickup screws and the screw holding the wiring support and the three stator clamping screws shown in the figure.
- Remove the stator and its wiring.



Refitting the stator

- Refit the stator and flywheel carrying out the removal procedure in reverse, tightening the retainers to the specified torque.

Locking torques (N*m)

Stator assembly screws (°) 3 ÷ 4



Refitting the flywheel cover

- Position the spline clip on the crankshaft and orient the end as shown in the figure.



- Orient the water pump shaft with reference to the transmission gear seat as shown in the photo.

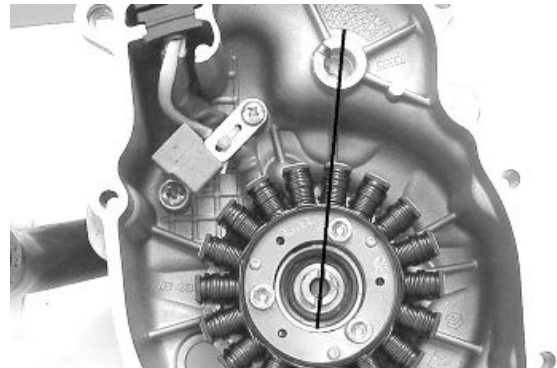

- Refit the cover over the engine and tighten the screws to the prescribed torque.
- Carry out the steps in the reverse order from the dismantling procedure.

CAUTION

TAKE CARE TO CORRECTLY POSITION THE FLYWHEEL CONNECTOR. MAKE SURE THE CENTRING DOWELS ARE PRESENT.

Locking torques (N*m)

Flywheel cover screws 11 - 13

Flywheel and starting

Removing the starter motor

- Remove the two screws indicated in the figure.
- Take the starter motor out of its seat

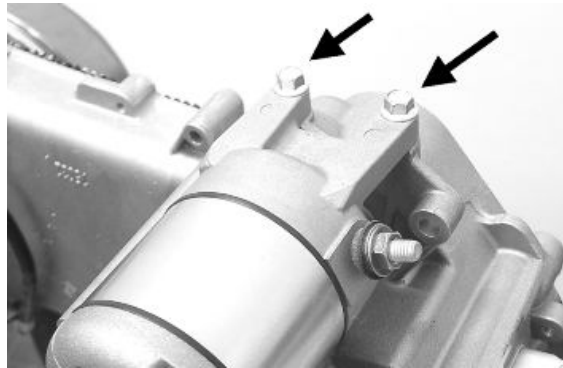

Removing the flywheel magneto

- Remove the water pump shaft and crankshaft spline clip



- Line up the two holes in the flywheel as shown in the photo



- Screw in the guide bushing that is part of the special flywheel stop tool on the flywheel as shown in the photo.



-
- Insert the special flywheel stop tool on the flywheel as shown in the photo

Specific tooling

020627Y Flywheel lock wrench



-
- Remove the plate indicated in the photo.

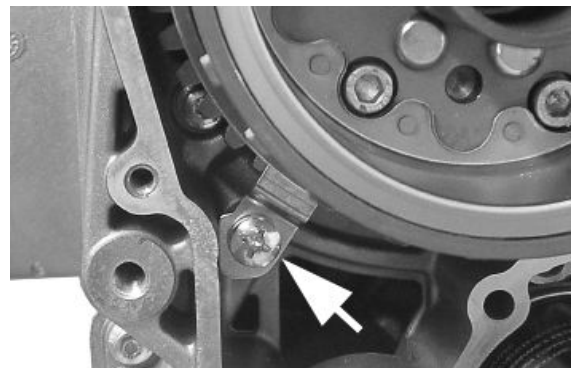

-
- Remove the flywheel nut with its washer
 - Do up the flywheel nut by three or four threads so that the flywheel does not fall accidentally on extraction
 - Screw the extractor onto the flywheel and extract it as shown in the photograph

Specific tooling

020467Y Flywheel extractor

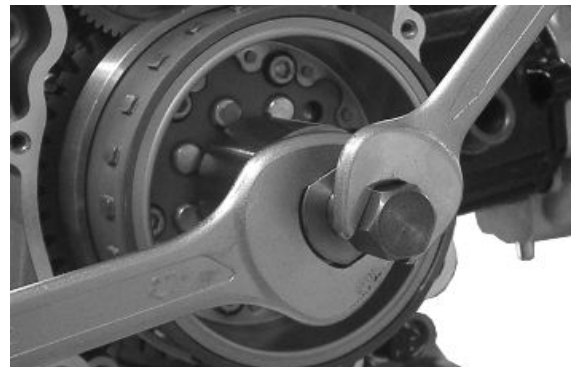

Inspecting the flywheel components

- Check the integrity of the internal plastic parts of the flywheel and the Pick-Up control plate.

Refitting the free wheel

- Make sure the freewheel faying surfaces are in good condition.
- Thoroughly clean the free wheel to remove LOCTITE residue.
- Degrease the threading of the holes in the free wheel and the clamping screws.
- Apply the recommended product to the end of the screws.

Recommended products

Loctite 243 Medium strength threadlock

Loctite 243 medium-strength threadlock

- Fit the freewheel on the magneto flywheel making sure that the ground side is in contact with the flywheel itself, i.e. with wheel seeger ring visible.
- Lock the six clamping screws in criss-cross fashion to the prescribed torque.

Locking torques (N*m)

Screw fixing freewheel to flywheel 13 ÷ 15



- Oil the free wheel "rollers".

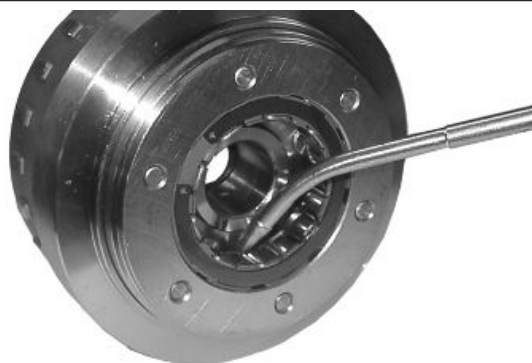

Refitting the flywheel magneto

- Remove the freewheel retaining plate indicated in the photograph
- Remove the transmission gear and the freewheel



- Insert the free wheel on the flywheel as shown in the photo
- Then refit the flywheel with free wheel and transmission gear



- Using the special flywheel stop tool, tighten up the flywheel fixing nut to the prescribed torque
- Refit the retention plate



Specific tooling

020627Y Flywheel lock wrench

Locking torques (N*m)

Flywheel nut 94 ÷ 102

Refitting the starter motor

- Fit a new O-ring on the starter motor and lubricate it.
- Fit the starter on the crankcase, locking the two screws to the prescribed torque.

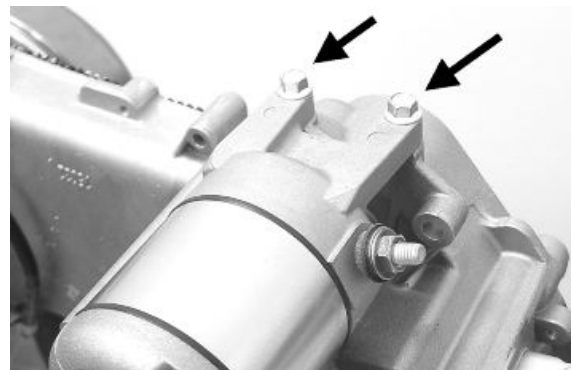

Locking torques (N*m)

Starter motor screws 11 ÷ 13

Cylinder assy. and timing system

Removing the intake manifold

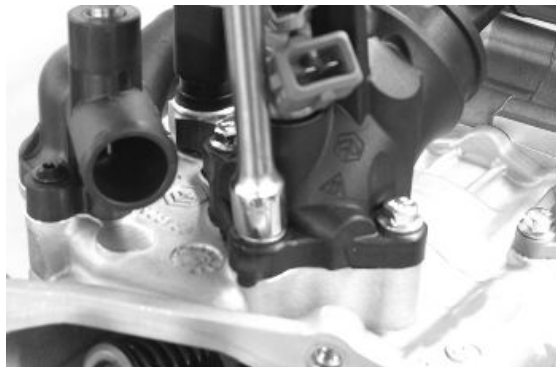

Loosen the three screws and remove the air intake manifold.

- When refitting, secure to the specified torque.

Removing the rocker-arms cover

- Remove the 5 screws indicated in the figure



Removing the timing system drive

- Remove the parts listed below first: transmission cover, drive pulley with belt, oil sump with spring and by-pass piston, oil pump pulley cover, O-ring on the crankshaft and the sprocket wheel separation washer.
- Remove the tappet cover.
- Remove the central screw fastener and the automatic valve-lifter retaining cover, as shown in the figure.
- Remove the return spring of the automatic valve lifter unit and the automatic valve lifter unit and its end of stroke washer.

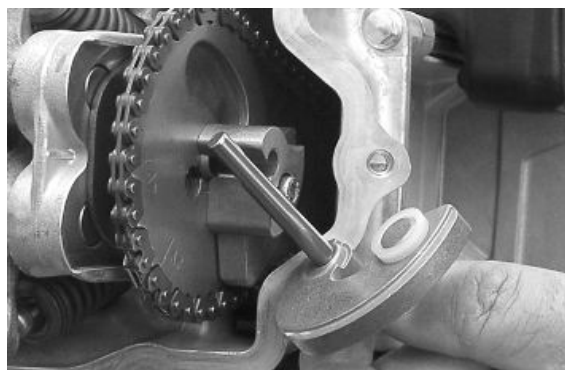

- Loosen the central screw on the tensioner first.
- Remove the two fixings shown in the figure.
- Remove the tensioner with its gasket.



- Remove the internal hex screw and the counterweight shown in the figure.

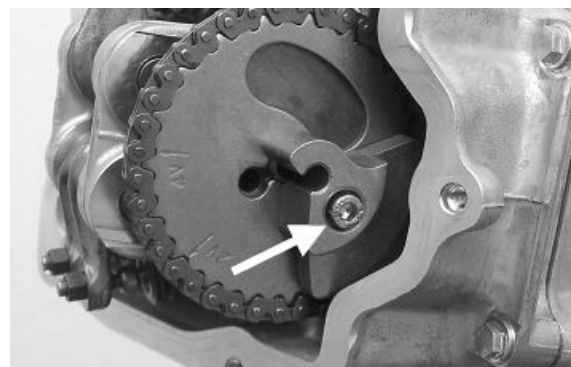

- Remove the camshaft control pulley with its washer.



- Remove the command sprocket wheel and the timing chain.
 - Remove the screws indicated in the figure, the spacer bar and the tensioner slider.
- The chain tensioning pad must be removed from the transmission side. As regards the lower chain guide pad, it may only be removed after the head has been removed.

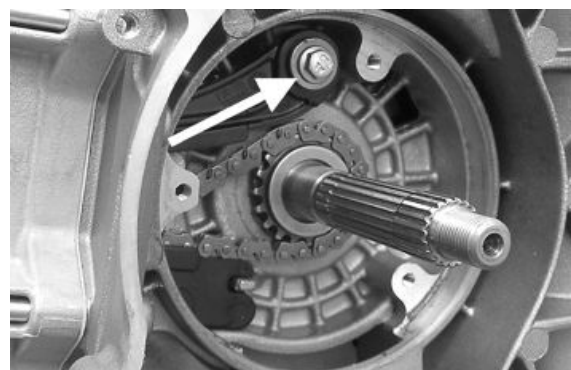

N.B.

IT IS ADVISABLE TO MARK THE CHAIN IN ORDER TO ENSURE THAT THE INITIAL DIRECTION OF ROTATION IS MAINTAINED.

Removing the cam shaft

- Remove the two screws and the cam shaft re-tainer shown in the diagram.
- Remove the cam shaft.
- Remove the pins and the rocker arms from the flywheel side holes.

N.B.

IN CASE OF NEED, THE HEAD MAY BE REMOVED WITH THE CAMSHAFT, PINS, ROCKING LEVERS AND FIXING BRACKET. THE HEAD CAN ALSO BE REMOVED WITHOUT REMOVING THE CHAIN AND THE DRIVING SHAFT CHAIN TIGHTENER.

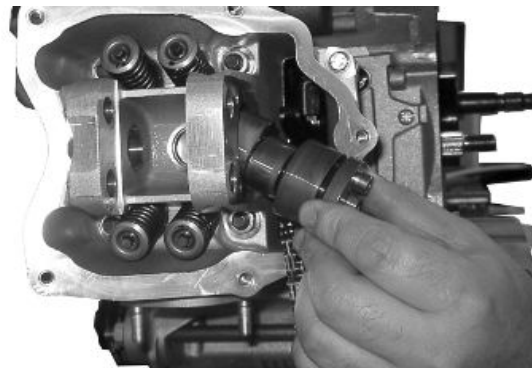
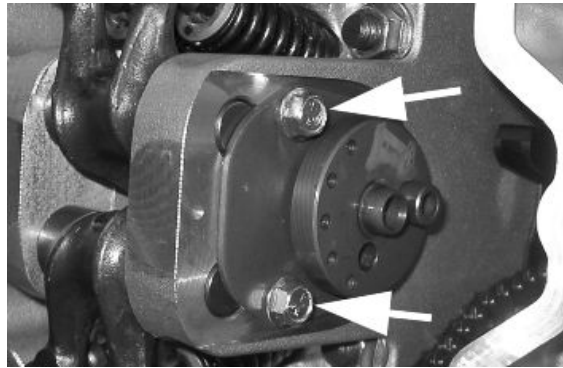

Removing the cylinder head

- Remove the spark plug.
- Remove the 2 side fixings shown in the figure.
- Loosen the 4 head-cylinder fastening nuts in two or three stages and in criss-cross fashion.
- Remove the head, the two centring dowels and the gasket.

N.B.

IN CASE OF NEED, THE HEAD MAY BE REMOVED WITH THE CAMSHAFT, PINS, ROCKING LEVERS AND FIXING BRACKET. THE HEAD CAN ALSO BE REMOVED WITHOUT REMOVING THE CHAIN AND THE DRIVING SHAFT CHAIN TIGHTENER.

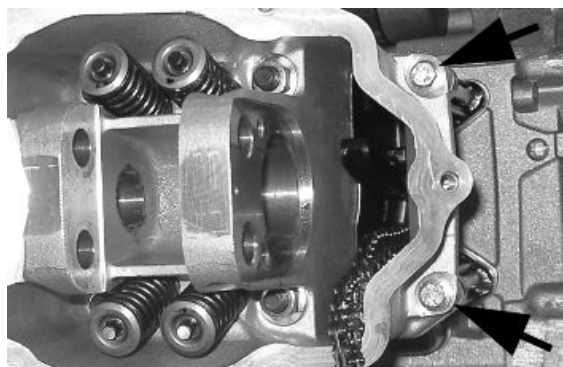

Removing the valves

- Using the appropriate tool fitted with an adaptor, remove the cotters, caps, springs and valves.
- Remove the oil guards with the appropriate tool.
- Remove the lower spring supports.

CAUTION

REPLACE THE VALVES IN SUCH A WAY AS TO RECOGNISE THEIR ORIGINAL POSITION ON THE HEAD.

Specific tooling

020382Y011 adapter for valve removal tool

020382Y Valve cotters equipped with part 012 removal tool

020431Y Valve oil seal extractor



Removing the cylinder - piston assy.

Removing cylinder and piston

- Remove the chain guide pad.
- Remove the 4 O-rings on the stud bolts.
- Pull out the cylinder.
- Remove the cylinder base gasket.
- Remove the two stop rings, the wrist pin and the piston.
- Remove the piston seals.

CAUTION

TO AVOID DAMAGING THE PISTON, SUPPORT IT WHILE REMOVING THE CYLINDER.

N.B.

BE CAREFUL NOT TO DAMAGE THE SEALING RINGS DURING REMOVAL.

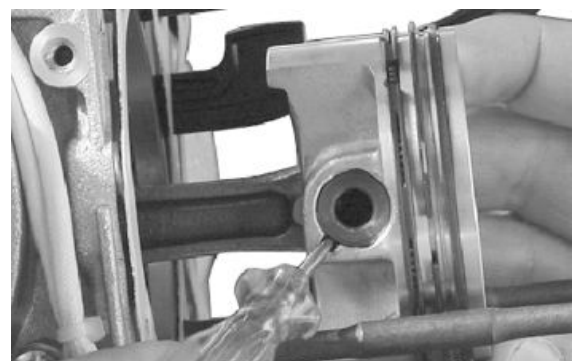
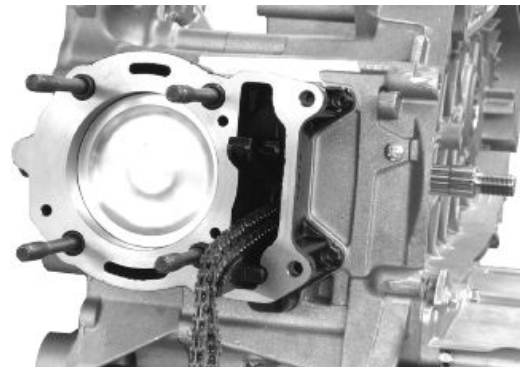

Inspecting the small end

N.B.

TO MEASURE WEAR LIMITS AND COUPLING CLEARANCES, SEE THE SPECIFICATIONS CHAPTER.

See also

[Crankcase - crankshaft - connecting rod](#)

Inspecting the wrist pin

N.B.

TO MEASURE WEAR LIMITS AND COUPLING CLEARANCES, SEE THE SPECIFICATIONS CHAPTER.

See also

[Cylinder - piston assy.](#)

Inspecting the piston

N.B.

TO MEASURE WEAR LIMITS AND COUPLING CLEARANCES, SEE THE SPECIFICATIONS CHAPTER.

See also

[Cylinder - piston assy.](#)

Inspecting the cylinder

N.B.

TO MEASURE WEAR LIMITS AND COUPLING CLEARANCES, SEE THE SPECIFICATIONS CHAPTER.

See also

[Cylinder - piston assy.](#)

Inspecting the piston rings

N.B.

TO MEASURE WEAR LIMITS AND COUPLING CLEARANCES, SEE THE SPECIFICATIONS CHAPTER.

See also

[Piston rings](#)

Removing the piston

- Install piston and wrist pin onto the connecting rod, aligning the piston arrow the arrow facing towards the exhaust.
- Fit the wrist pin snap ring onto the appropriate tool
- With opening in the position indicated on the tool
S = left
D= right
- Place the wrist pin snap ring into position using a punch
- Fit the wrist pin snap ring using the plug as shown in the figure



N.B.

THE TOOL FOR INSTALLING THE STOP RINGS MUST BE USED MANUALLY.

CAUTION

USING A HAMMER MIGHT DAMAGE THE STOPS' HOUSING.

Specific tooling

020454Y Pin lock fitting tool

Choosing the gasket

- Provisionally fit the piston into the cylinder, without any base gasket.
- Assemble a dial gauge on the specific tool.

Specific tooling

020428Y Piston position check support

- Using an abutment plane, reset the comparator with a preload of a few millimetres.
- Finally fix the comparator.
- Check the perfect sliding of the feeler pin.
- Install the tool on the cylinder without changing the comparator position.
- Lock the tool using the original head fixing nuts.
- Rotate the crankshaft up to the TDC (the inversion point of the dial gauge rotation)
- Measure the deviation from the reset value.



- By means of the table, see the Specifications chapter identify the cylinder base gasket thickness to be used for refitting. Correctly identify the cylinder base gasket thickness to keep the correct compression ratio.
- Remove the special tool and the cylinder.

N.B.

IF DEVIATIONS (OR RECESSES OR PROJECTIONS) CLOSE TO THE CHANGE OF CATEGORY ARE MEASURED, REPEAT THE MEASUREMENT AT THE OPPOSED SIDE. TO DO SO, REPEAT THE TOOL INSTALLATION BY INVERTING ITS POSITION.

See also

[Slot packing system](#)

Refitting the piston rings

- Place the scraper ring spring on the piston.
- Install the scraper ring keeping the opening opposed to the spring junction and with the writing "top" facing the piston top. The chamfered side of the oil scraper ring should always be facing the piston crown.
- Fit the second lining with the identification letter or the writing "top" facing the piston crown. In any case, the step must be facing opposite the piston top.
- Install the first compression lining in the direction imposed by the housing.
- It is advisable to use a fitter to facilitate the installation of the linings.

**N.B.**

THE TWO PISTON RINGS ARE MADE WITH A TAPERED CYLINDRICAL CONTACT CROSS-SECTION. THIS IS TO ACHIEVE A BETTER BEDDING.

- Misalign the lining openings at 120° as shown in the figure.
 - Lubricate the components with engine oil.
 - The engine uses the first compression lining with an L section.
-

Refitting the cylinder

- Insert the cylinder base gasket with the thickness determined above.
- Using the fork support and the piston ring retaining band, refit the cylinder as shown in the figure.

N.B.

BEFORE FITTING THE CYLINDER, CAREFULLY BLOW OUT THE LUBRICATION DUCT AND OIL THE CYLINDER BARREL.

Specific tooling

020426Y Piston fitting fork

020393Y Piston fitting band



Inspecting the cylinder head

N.B.

TO MEASURE WEAR LIMITS AND COUPLING CLEARANCES, SEE THE SPECIFICATIONS CHAPTER.

See also

[Cylinder Head](#)

Inspecting the timing system components

- Check that the guide shoe and the tensioner shoe are not worn out.
- Ensure that the camshaft control pulley chain assembly and the sprocket wheel are not worn.
- If you encounter wear, replace the parts or, if the chain, sprocket wheel and pulley are worn replace the whole assembly.
- Remove the centre screw with the washer and the tensioner spring. Check that the one-way mechanism is not worn.
- Check the condition of the tensioner spring.
- If examples of wear are found, replace the whole assembly.

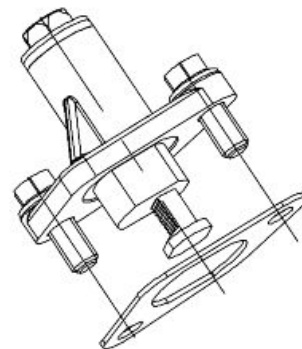
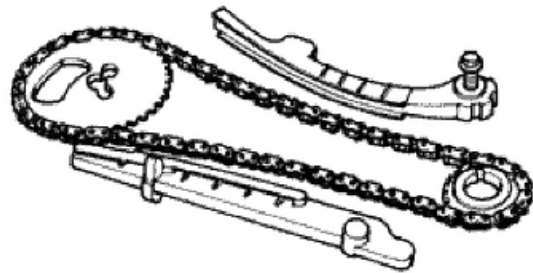

Inspecting the valve sealings

N.B.

TO MEASURE WEAR LIMITS AND COUPLING CLEARANCES, SEE THE SPECIFICATIONS CHAPTER.

See also

[Cylinder Head](#)

Inspecting the valves

N.B.

TO MEASURE WEAR LIMITS AND COUPLING CLEARANCES, SEE THE SPECIFICATIONS CHAPTER.

See also

[Cylinder Head](#)

Inspecting the springs and half-cones

- Check that the upper and lower supporting spring washers, the cotters and the oil seal show exhibit no signs of abnormal wear. Replace a component when worn.

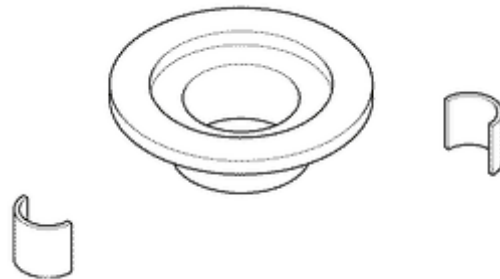

- Measure the unloaded spring length.

N.B.

TO MEASURE WEAR LIMITS AND COUPLING CLEARANCES, SEE THE SPECIFICATIONS CHAPTER.

See also

[Cylinder Head](#)

Refitting the valves

- Lubricate the valve guides with engine oil.
- Place the valve spring supports on the head.
- Using the special punch, fit the four valve seals.
- Fit the valves, the springs and the caps. Using the appropriate tool with adapter, compress the springs and insert the cotters in their seats.

N.B.

DO NOT CHANGE THE VALVE FITTING POSITION. FIT THE VALVE SPRINGS WITH THE REFERENCE COLOUR ON COTTER SIDE (TURNS WITH GREATER PITCH).



Specific tooling

020306Y Punch for assembling valve seal rings

020382Y Valve cotters equipped with part 012 removal tool

020382Y011 adapter for valve removal tool



Inspecting the cam shaft

N.B.

TO MEASURE WEAR LIMITS AND COUPLING CLEARANCES, SEE THE SPECIFICATIONS CHAPTER.

See also

[Cylinder Head](#)

Refitting the head and timing system components

- Refit the lower timing chain sprocket wheel on the crankshaft, with the chamfer facing the insertion side.
- Loop the timing chain around the sprocket on the crankshaft.
- Fit the chain tensioner slider from the cylinder head side.
- Fit the spacer and the screw fastener.
- Tighten the screws to the prescribed torque.
- Fit the pins and rocker arms.
- Lubricate the two rocking levers through the holes at the top.
- Lubricate the 2 bearings and insert the cam shaft in the cylinder head with the cams corresponding to the rockers.
- Insert the retention plate and tighten the two screws shown in the figure to the prescribed torque.
- Refit the spacer on the cam shaft.

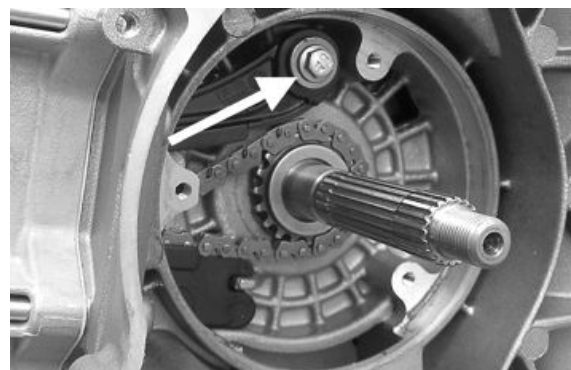

- Rotate the engine so that the piston is at top dead centre, using the reference marks on the flywheel and the crankcase.
- Holding this position insert the chain on the camshaft control pulley.
- Insert the pulley on the cam shaft while keeping the reference **4V** in correspondence with the reference mark on the head.
- Fit the counterweight and tighten the fixing screw to the prescribed torque.
- Fit the end-stop ring on the automatic valve-lifter cam and fit the automatic valve-lifter cam to the cam shaft.
- Fit the automatic valve-lifter return spring.
- During this operation the spring must be loaded by approximately 180°.
- Fit the automatic valve-lifter retaining dish, using the counterweight screw fastener as a reference.
- Tighten the clamping screw to the prescribed torque.
- Set the tensioner cursor in the rest position.
- Fit the chain tensioner on the cylinder, using a new gasket, and tight the two screws to the prescribed torque.
- Insert the chain tensioning screw, together with the spring and washer, tightening it to the prescribed torque.
- Adjust the valve clearance.
- Fit the spark plug.

Electrode distance 0.8 mm

N.B.

GREASE THE END STOP RING TO PREVENT IT COMING OUT AND FALLING INTO THE ENGINE.

Locking torques (N*m)

Timing chain tensioner support screw 11 ÷ 13
Spark plug 12 ÷ 14 **Starter ground screw 7 ÷ 8.5**
Timing chain tensioner slider screw 10 ÷ 14
Starter ground support screw 11 ÷ 15 **Timing chain tensioner central screw 5 - 6** **Camshaft retention plate screw 4 ÷ 6**

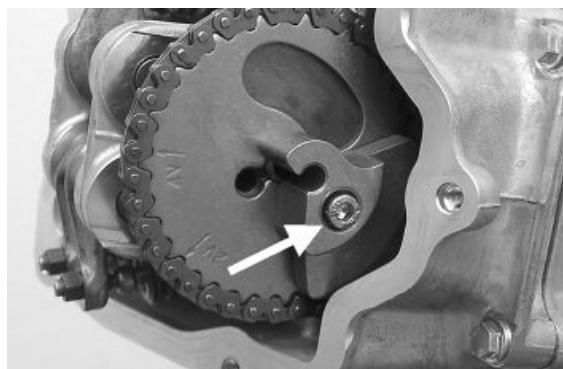

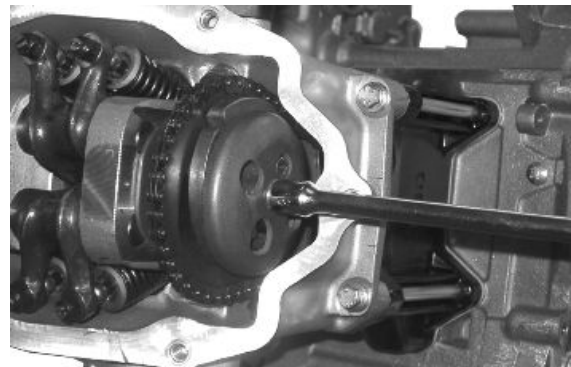
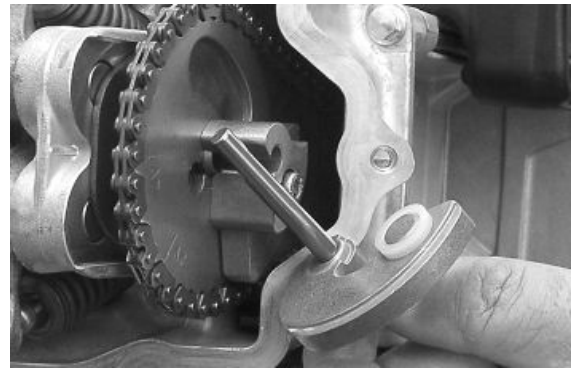

- Fit the timing chain guide pad.
- Insert the centring dowel between the cylinder head to the cylinder, fit the cylinder head gasket and the cylinder head.
- Lubricate the stud bolt threading.
- Tighten up the nuts to an initial pre-torque of 7 ± 1 N·m
- Tighten up the nuts to a second pre-torque of 10 ± 1 N·m
- Rotate by an angle of 270°
- To carry out the operations described above, follow the tightening sequence in the figure.

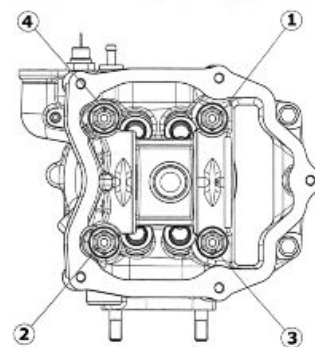

- Fit the two screws on the outside of the timing chain side and tighten them to the specified torque.

N.B.

BEFORE INSTALLING THE HEAD, MAKE SURE THAT THE LUBRICATION CHANNEL IS CLEAN USING A COMPRESSED AIR JET.

Locking torques (N*m)

Timing chain tensioner support screw 11 ÷ 13



Refitting the rocker-arms cover

- Refit the cylinder head cover, tightening the 5 clamping screws to the prescribed torque.
- Make sure the gasket is positioned properly.

Locking torques (N*m)

Tappet cover screws 6 - 7 Nm

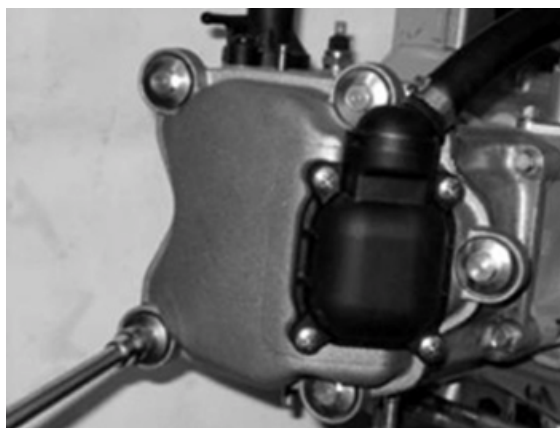

Refitting the intake manifold

Fit the intake manifold and do up the three screws.

Locking torques (N*m)

Inlet manifold screws 11 ÷ 13

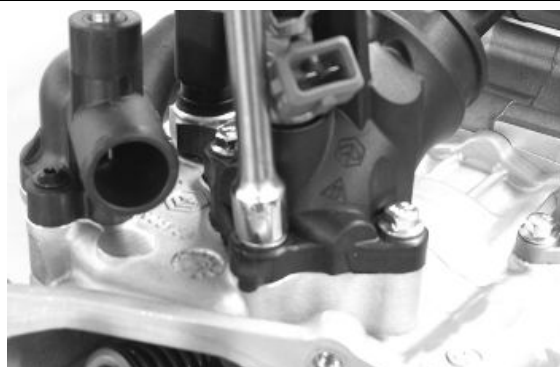

Crankcase - crankshaft

Splitting the crankcase halves

- Before opening the crankcase, it is advisable to check the axial clearance of the crankshaft. To do this, use a plate and a support with appropriate tool dial gauge.
- Upper clearances are an indication of wear on the surfaces of the crankshaft casing support.
- Remove the 10 crankshaft coupling screws.
- Separate the crankcase while keeping the crankshaft in one of the two halves of the crankcase.
- Remove the crankshaft.
- Remove the half crankcase coupling gasket.
- Remove the two screws and the internal cover shown in the diagram.
- Remove the oil guard on the flywheel side.
- Remove the oil filter fitting shown in the diagram.
- Check the axial clearance on the connecting rod.
- Check the radial clearance on the connecting rod.
- Check the surfaces that limit the axial free-play are not scored and measure the width of the crankshaft between these surfaces, as shown in the diagram.
- If the axial clearance between crankshaft and crankcase is exceeding and the crankshaft does not have any defect, the problem must be due to either excessive wear or wrong machining on the crankcase.
- Check the diameters of both the bearings of the crankshaft in accordance with the axes and surfaces shown in the figure. The half-shafts are classified in two categories Cat. 1 and Cat. 2 as shown the chart below.

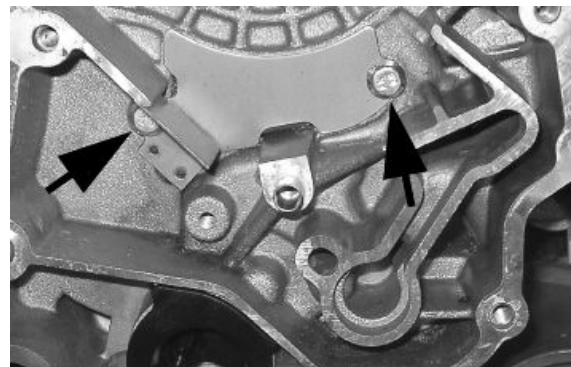
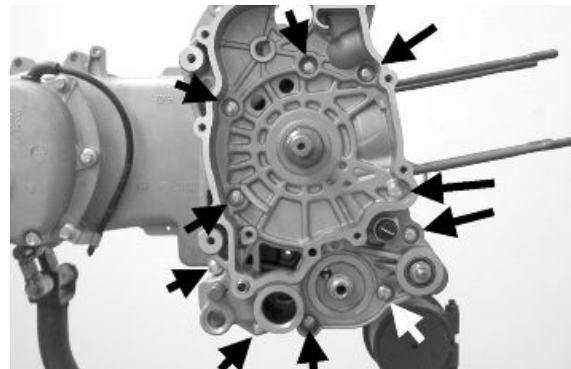
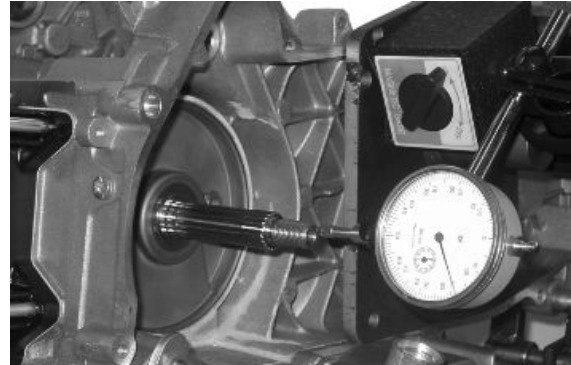

CAUTION

THE CRANKSHAFT CAN BE REUSED WHEN THE WIDTH IS WITHIN THE STANDARD VALUES AND THE SURFACES SHOW NO SIGNS OF SCORING.

CAUTION

WHILE OPENING THE CRANKCASES AND REMOVING THE DRIVING SHAFT, CHECK THAT THE THREADED SHAFT ENDS DO NOT INTERFERE WITH THE MAIN BUSHINGS. FAILURE TO OBSERVE THIS PRECAUTION CAN DAMAGE THE MAIN BUSHINGS.

CAUTION

KEEP THE CRANKSHAFT IN ONE OF THE TWO HALVES OF THE CRANKCASE WHEN SEPARATING IT. IF YOU FAIL TO DO THIS, THE CRANKSHAFT MIGHT ACCIDENTALLY FALL.

N.B.

WHEN MEASURING THE WIDTH OF THE CRANKSHAFT, MAKE SURE THAT THE MEASUREMENTS ARE NOT MODIFIED BY THE RADIUS OF FITTINGS WITH THE CRANKSHAFT BEARINGS.

N.B.

TO MEASURE WEAR LIMITS AND COUPLING CLEARANCES, SEE THE SPECIFICATIONS CHAPTER.

See also

[Crankcase - crankshaft - connecting rod](#)

Inspecting the crankshaft alignment**N.B.**

TO MEASURE WEAR LIMITS AND COUPLING CLEARANCES, SEE THE SPECIFICATIONS CHAPTER.

See also

[Crankcase - crankshaft - connecting rod](#)

Inspecting the crankcase halves

- Before proceeding to check the crankcase halves, thoroughly clean all surfaces and oil ducts.
- On the transmission-side crankcase half, take particular care when handling the oil pump compartment and the oil ducts, the by-pass duct, the main bushings and the cooling jet on the transmission side (see diagram).
- Take particular care, also, that there are no signs of wear in the oil by-pass valve housing (see Chapter Lubrication), as this could prevent a good seal in the valve, which regulates the oil pressure.
- On the flywheel side crankcase half, take particular care cleaning the oil ducts for the main bushings, the oil duct for the jet that lubricates the cylinder head and the oil drainage duct at the flywheel side oil seal.

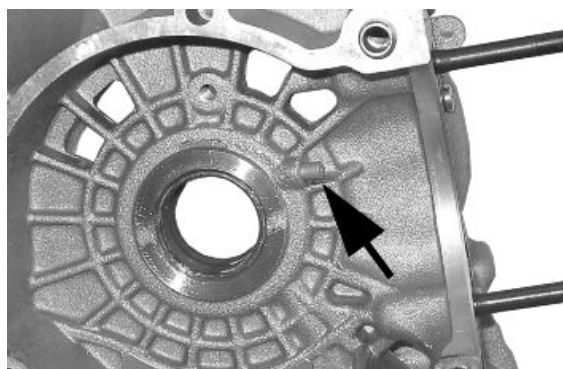

- Inspect the coupling surfaces on the crankcase halves for scratches or deformation, taking particular care with the cylinder/crankcase surfaces and the crankcase halves surfaces.

- Defects in the crankcase coupling gasket between the crankcase halves or the mating surfaces shown in the diagram, could cause a drop in the oil pressure lubricating the main bearings and connection rod.



- Check the main bearing seats that limit axial clearance in the crankshaft show no signs of wear. The dimension between these seats is measured by way of the procedure described previously for measuring the crankshaft axial clearance and dimensions.

N.B.

THE JET IS FED THROUGH THE MAIN BUSHINGS. PROPER OPERATION OF THIS COMPONENT IMPROVES THE PISTON TOP COOLING. CLOGGING HAS EFFECTS THAT ARE DIFFICULT TO DETECT (PISTON TEMPERATURE INCREASE). FAILURE OR LEAK CAN CONSIDERABLY DECREASE THE MAIN BUSHING AND CONNECTING ROD LUBRICATION PRESSURE.

N.B.

THE HEAD LUBRICATION CHANNEL IS PROVIDED WITH A SHUTTER JET; THIS GIVES A "LOW PRESSURE" HEAD LUBRICATION; THIS CHOICE WAS MADE TO REDUCE THE OIL TEMPERATURE IN THE SUMP. THE JET CLOGGING IMPAIRS THE HEAD LUBRICATION AND THE TIMING MECHANISMS. A JET FAILURE CAUSES A DECREASE OF THE MAIN BUSHING AND CONNECTING ROD LUBRICATION PRESSURE.

Inspecting the crankshaft plain bearings

- To obtain a good bushing lubrication it is necessary to have both an optimal lubricating pressure and a good oil flow rate; the bushings must be correctly positioned so as not to obstruct the oil supply channels.

- The main bushings are comprised of two half-bearings, one with holes and channels for lubrication whereas the other is solid.

Characteristic

Lubrication pressure

3.5 ÷ 4 bar

- The solid half-bearing is intended to stand the thrusts caused by combustion, and for this reason it is arranged opposite the cylinder.
- To prevent obstructions in the oil feeding channels, the matching surface of the two half-bearings must be perfectly perpendicular to the cylinder axis, as shown in the figure.
- The oil feeding channel section is also affected by the bushings driving depth compared with the crankshaft axial clearance of the limiting surface.

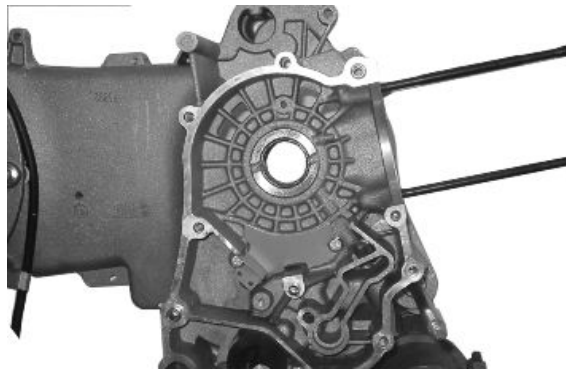

N.B.

TO MEASURE WEAR LIMITS AND COUPLING CLEARANCES, SEE THE SPECIFICATIONS CHAPTER.

See also

[Crankcase - crankshaft - connecting rod](#)

Refitting the crankcase halves

- Fit the internal bulkhead by locking the two screws to the prescribed torque.
- Fit the oil filter fitting and tighten it to the specified torque.
- Position the oil pre-filter element as shown in the photograph.
- Place a new gasket on one of the crankcase halves, preferably on the transmission side, together with the locating dowels.
- Lubricate the main bushings and insert the crankshaft in the transmission side crankcase half.
- Reassemble the two crankcase halves.
- Fit the 10 screws and tighten them to the prescribed torque.
- Fit a new O-ring on the pre-filter and lubricate it.
- Insert the filter on the engine with the relative cap. Tighten to the prescribed torque.

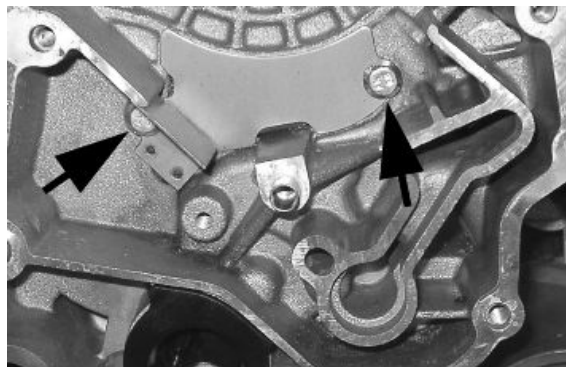

Locking torques (N*m)

Internal engine crankcase bulkhead (transmission-side half shaft) screws 4 ÷ 6
Engine-crankcase coupling screws 11 ÷ 13
Oil filter on crankcase fitting 27 ÷ 33
Engine oil drainage plug/mesh filter 24 ÷ 30

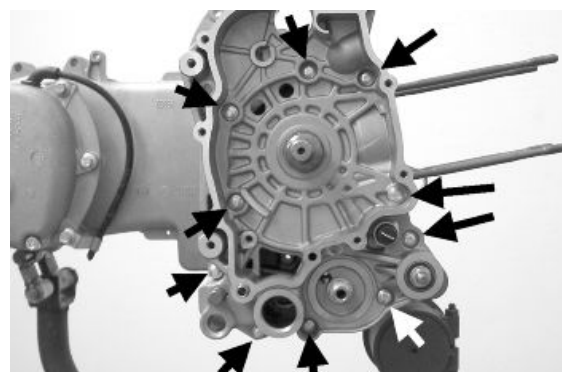

Studs

Check that the stud bolts have not worked loose from their seat in the crankcase.

Check the depth of stud bolt driving with a gauge, as indicated in the photograph. If it varies significantly from the driving depth indicated, it means that the stud bolt has yielded.

In this case, replace it.

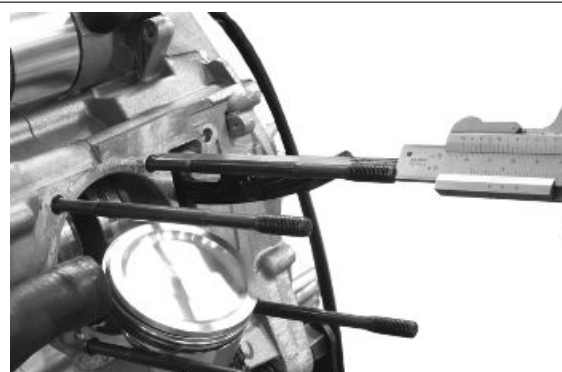

By working on two fitted cylinder head fixing nuts, nut and lock nut, as shown in the photograph, remove the stud bolt from its seat.

Clean the threaded seat on the carter thoroughly. Refit a new stud bolt and apply the special product on the threading crankcase side.

Tighten up to the depth of the driving indicated.

Recommended products

Loctite 'Quick Set' Strong 270 threadlock

Strong 270 threadlock

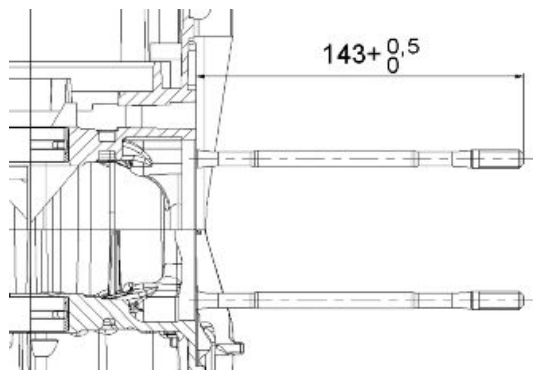

Lubrication

Conceptual diagrams

LUBRICATION CIRCUIT

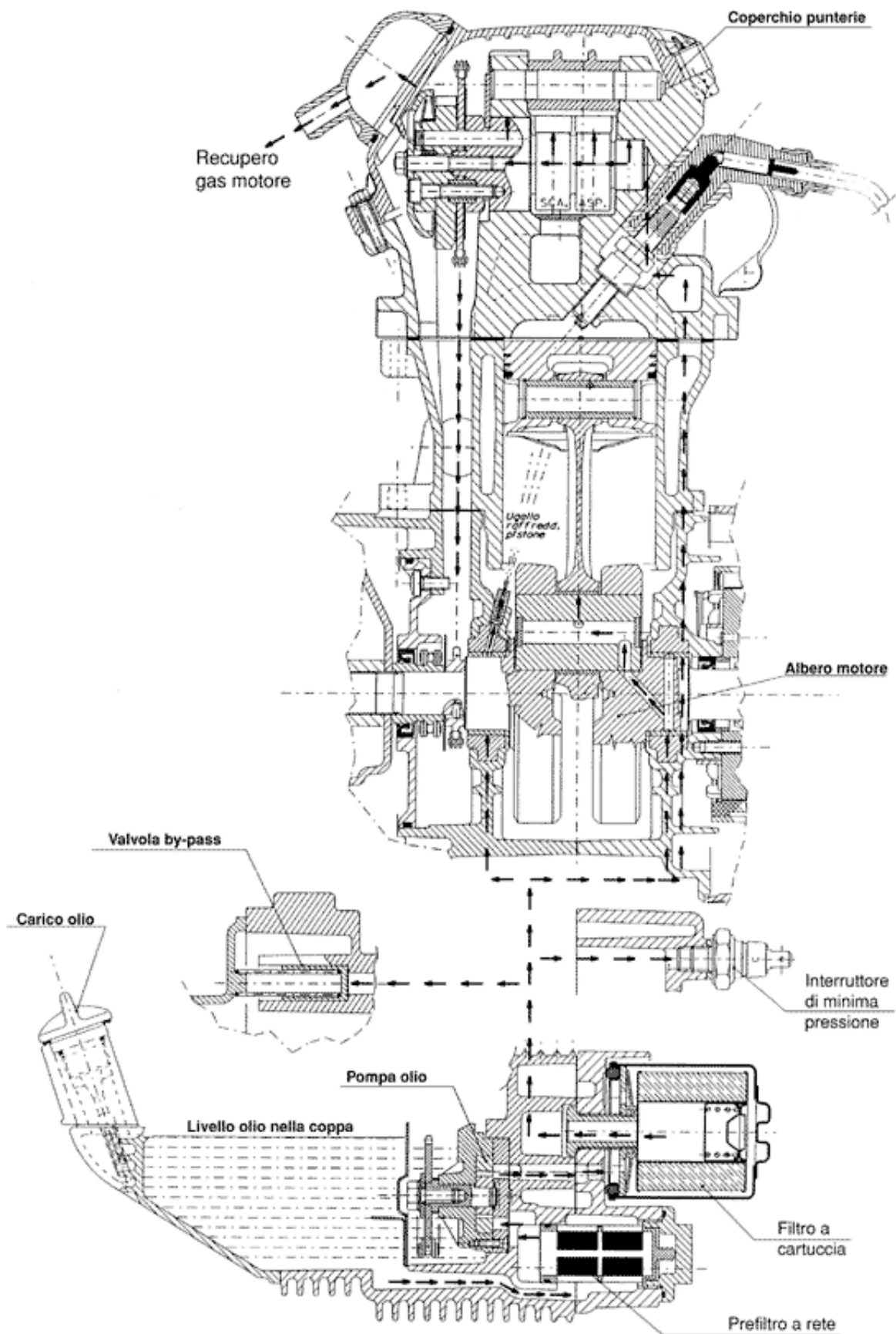

Oil pressure check

- Remove the electrical minimum oil pressure switch connection and remove the switch.
- Check the oil pressure reading is between 0.5 and 1.2 atm with the engine idling at 1650 rpm and the oil at the required temperature (wait for at least one electric ventilation).
- Check the oil pressure is between 3.2 and 4.2 atm with the engine running at a speed 6000 rpm and the oil at the required temperature.
- Remove the appropriate tools once the measurement is complete, refit the oil pressure switch and washer, tightening it to the specified torque and fit the fan cover.
- If the oil pressure is not within the specified limits, in the following order, check: the oil filter, the oil by-pass valve, the oil pump and the crankshaft seals.

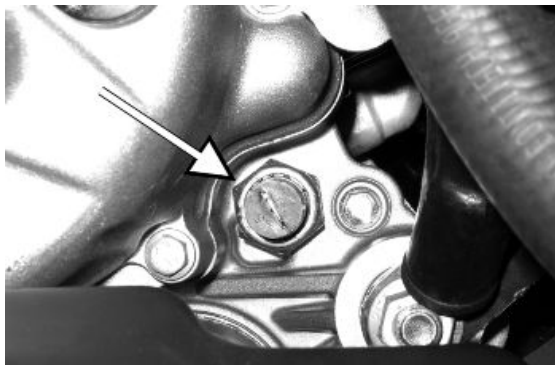
**N.B.**

THE CHECK MUST BE CARRIED OUT WITH OIL AT THE CORRECT LEVEL AND WITH AN OIL FILTER IN GOOD CONDITION.

Characteristic**Oil pressure**

Minimum pressure admitted at 6000 rpm: 3.2 atm.

Locking torques (N*m)

Minimum oil pressure sensor 12 ÷ 14

Crankshaft oil seals

Removal

- First remove the transmission cover and the complete driving pulley

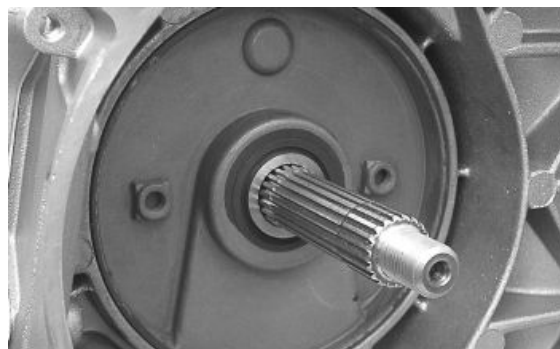

- Install the base of the appropriate tool on the oil guard using the screws provided.

Specific tooling

020622Y Transmission-side oil guard punch

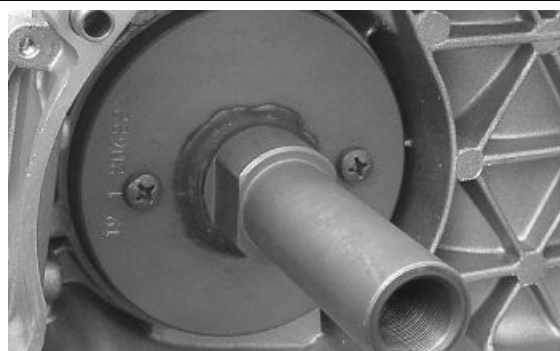

- Screw the threaded bar onto the base of the tool and extract the oil guard.

Specific tooling

020622Y Transmission-side oil guard punch

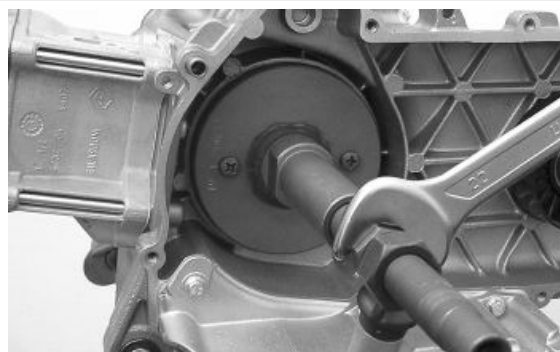

Refitting

- Use a new oil guard for the refitting
- Prepare the new oil guard, lubricating the sealing lip.
- Preassemble the oil seal with the specific tool, positioning the screws.
- Insert the sheath over the crankshaft.
- Insert the tool with the oil seal on the crankshaft until it comes into contact with the crankcase.
- Insert the adaptor bushing of the tool in the hole on the crankcase.

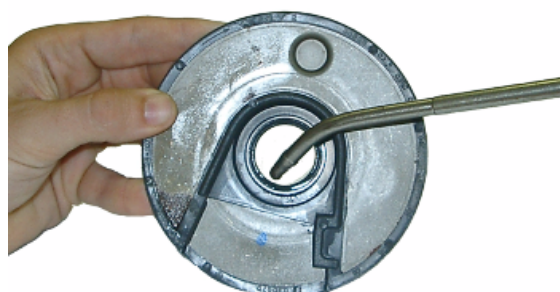

- Orientate the oil guard by inserting the bracket which is part of the appropriate tool
- Tighten the threaded bar onto the crankshaft as far as it will go.
- Use the nut to move the base of the tool until you can see end of the oil guard driving stroke
- Remove all of the tool components following the inverse procedure

CAUTION

DO NOT LUBRICATE THE SURFACE FOR KEYING ONTO THE ENGINE CRANKCASE.

CAUTION

ORIENT THE OIL GUARD BY POSITIONING THE CHAIN HOUSING CHANNEL FACING DOWNWARDS. WHEN THE POSITION IS REACHED, DO NOT RETRACT THE OIL GUARD. FAILURE TO COMPLY WITH THIS RULE CAN CAUSE A WRONG POSITIONING OF THE OIL GUARD SHEATH.

CAUTION

FAILURE TO COMPLY WITH THIS ASSEMBLY PROCEDURE CAN SERIOUSLY DAMAGE THE ENGINE DUE TO THE WRONG TENSIONING OF THE OIL PUMP CONTROL CHAIN.

Specific tooling

020622Y Transmission-side oil guard punch

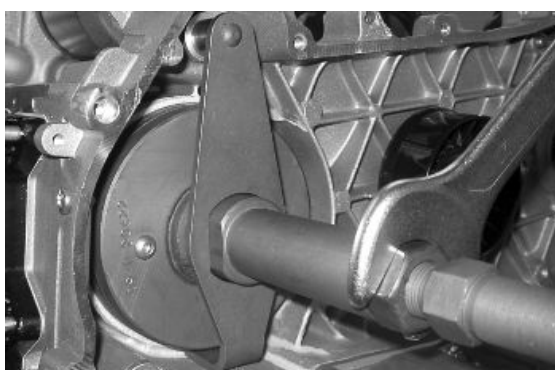
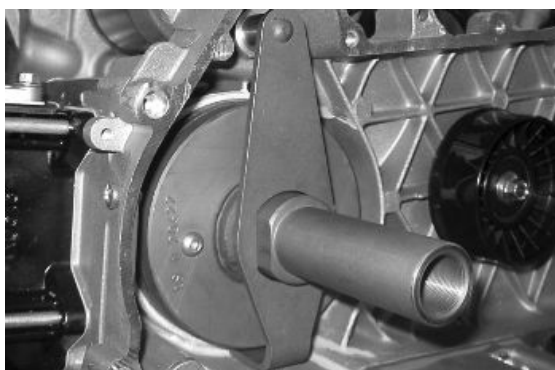
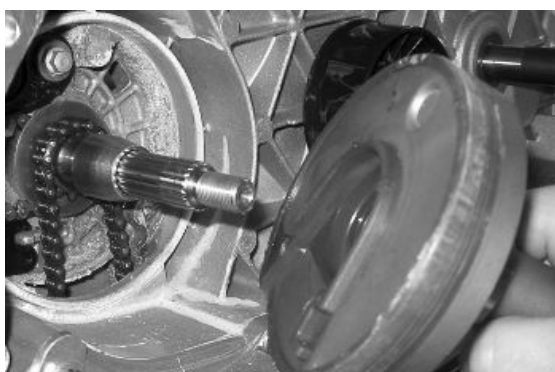
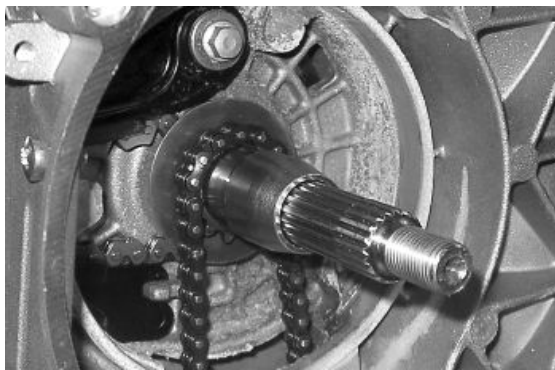

Oil pump

Removal

- Undo the two clamping screws in the figure and remove the cover over the pump control crown.

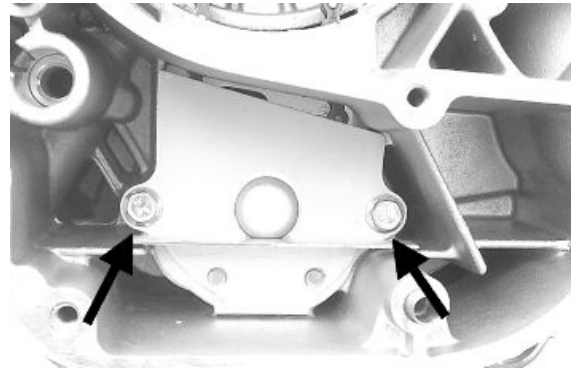

- Block the rotation of the oil pump control pulley with a screwdriver inserted through one of its two holes.
- Remove the central screw with Belleville washer, as shown in the diagram.
- Remove the chain with the crown.
- Remove the control sprocket with relative O-ring.
- Remove the oil pump by undoing the two screws in the figure.
- Remove the oil pump seal.

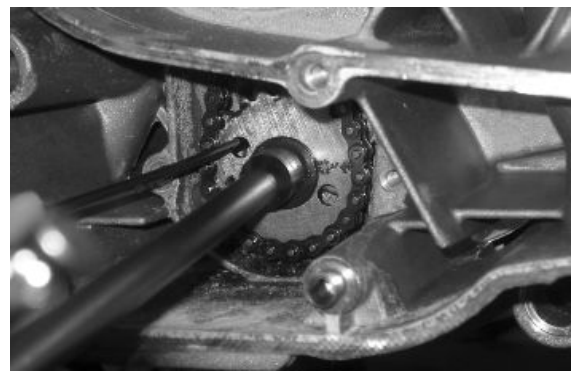

N.B.

IT IS ADVISABLE TO MARK THE CHAIN IN ORDER TO ENSURE THAT THE INITIAL DIRECTION OF ROTATION IS MAINTAINED.

Inspection

- Remove the two screws and the oil pump cover.
- Remove the clip retaining the innermost rotor.
- Remove and wash the rotors thoroughly with petrol and compressed air.
- Reassemble the rotors in the pump body, keeping the two reference marks visible. Replace the snap ring.

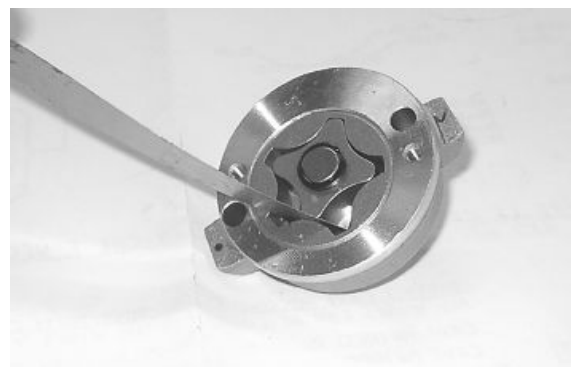

- Check the clearance between the rotors in the position shown in the diagram using a thickness gauge.

Measure the distance between the outer rotor and the pump body (see figure).

- Check the axial clearance of the rotors using a trued bar as shown in the figure.



Characteristic

Axial rotor clearance

Limit values admitted: 0.09 mm

Distance between the outer rotor and the pump body

Admissible limit clearance: 0.20 mm

Distance between the rotors

Admissible limit clearance: 0.12 mm

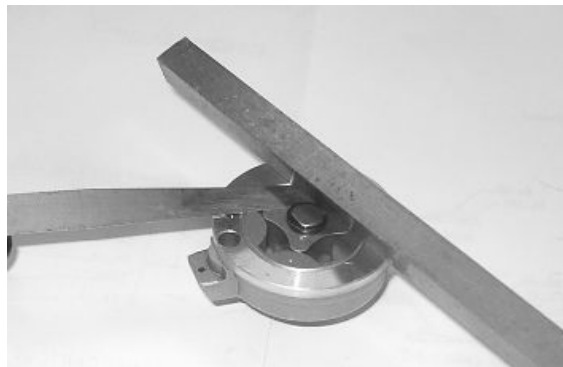

Refitting

- Check there are no signs of wear on the oil pump shaft or body.
- Check there are no signs of scoring or wear on the oil pump cover.
- If you detect non-conforming measurements or scoring, replace the faulty parts or the unit.
- Fit the pump cover in the position that permits the crankcase fixing screws to be aligned.
- Make sure the gasket is positioned properly and refit the pump on the engine crankcase. The pump can only be fitted in one position. - Tighten the screws to the prescribed torque.

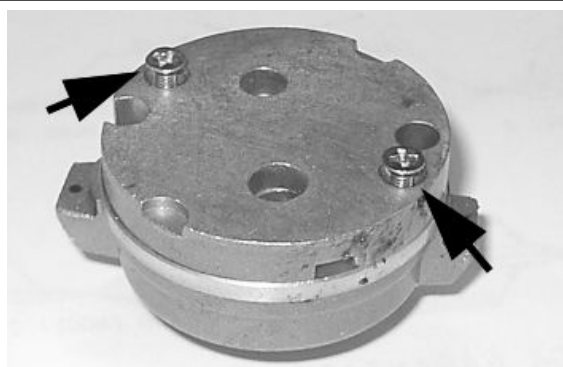

- Fit the sprocket wheel with a new O-ring.
 - Fit the chain.
 - Fit the central screw and the belleville washer.
- Tighten to the prescribed torque.
- Fit the oil pump cover by tightening the two screws to the prescribed torque.

N.B.

FIT THE BELLEVILLE WASHER SO THAT ITS OUTER RIM TOUCHES THE PULLEY. MAKE SURE THAT THE PUMP TURNS FREELY.

Locking torques (N*m)

Screws fixing oil pump to crankcase 5 - 6 Oil pump control crown screw 10 ÷ 14 Oil pump cover screws 0.7 ÷ 0.9

Removing the oil sump

- Remove the oil filler plug, the transmission cover, the complete driving pulley assembly with belt and the sprocket wheel, as described in the "Transmission" chapter.
- Drain the oil as described previously.
- Remove the seven screws, shown in the diagram, and the two rear brake fluid pipe fixing brackets.
- Remove the screw, the by-pass piston, the gasket and centring dowels shown in the figure.

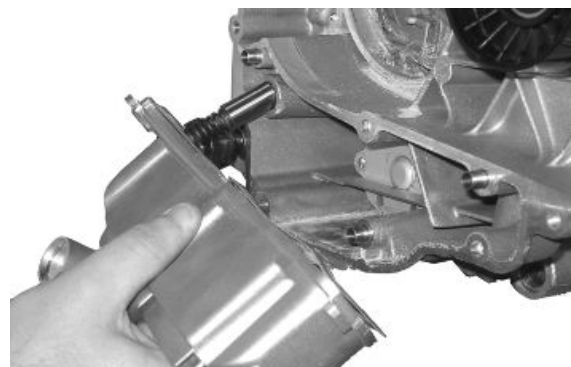
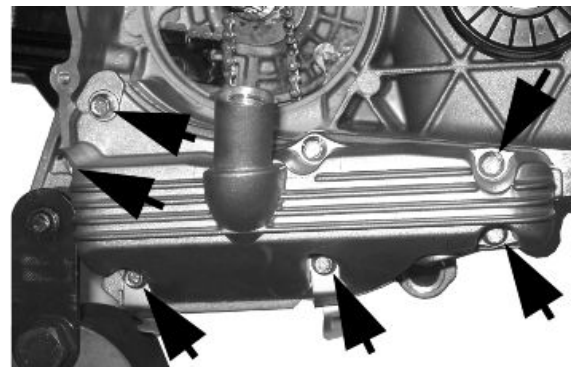

Inspecting the by-pass valve

- Check the unloaded spring length.
- Check that the small piston is not scored.
- Ensure that it slides freely on the crankcase and that it guarantees a good seal.
- If not, eliminate any impurities or replace defective parts.

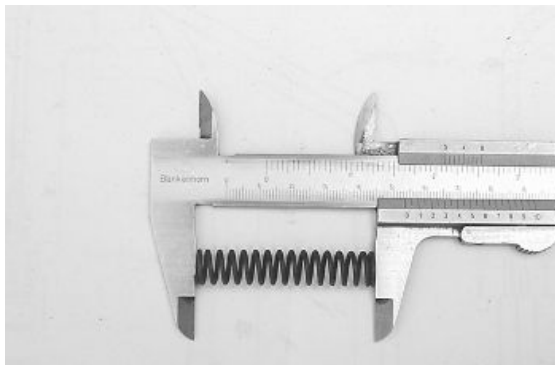

Characteristic

By-pass check up: Standard length

54.2 mm

Refitting the oil sump

- Refit the by-pass valve plunger in its housing.
- Insert the pressure-regulating spring.
- Fit a new sump seal.
- Refit the two centring dowels.
- Refit the sump, taking care to locate the spring in the appropriate recess machined into the inside of the sump.
- Refit the rear brake cable brackets and the screws in the reverse order from which they were removed.
- Tighten the screws to the prescribed torque.
- Refit the drive pulley assembly, the drive belt, the sprocket wheel and the transmission cover, as described in the "Transmissions" chapter.
- **When testing the lubrication system, refer to chapter "Crankcase and Crankshaft", regarding lubrication of the crankshaft and connecting rod**

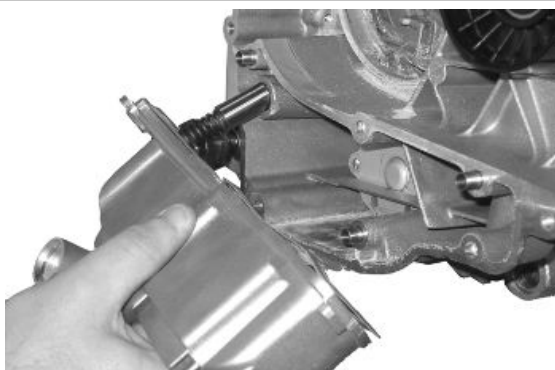

Locking torques (N*m)

Oil sump screws 10 ÷ 14

INDEX OF TOPICS

INJECTION

INJEC

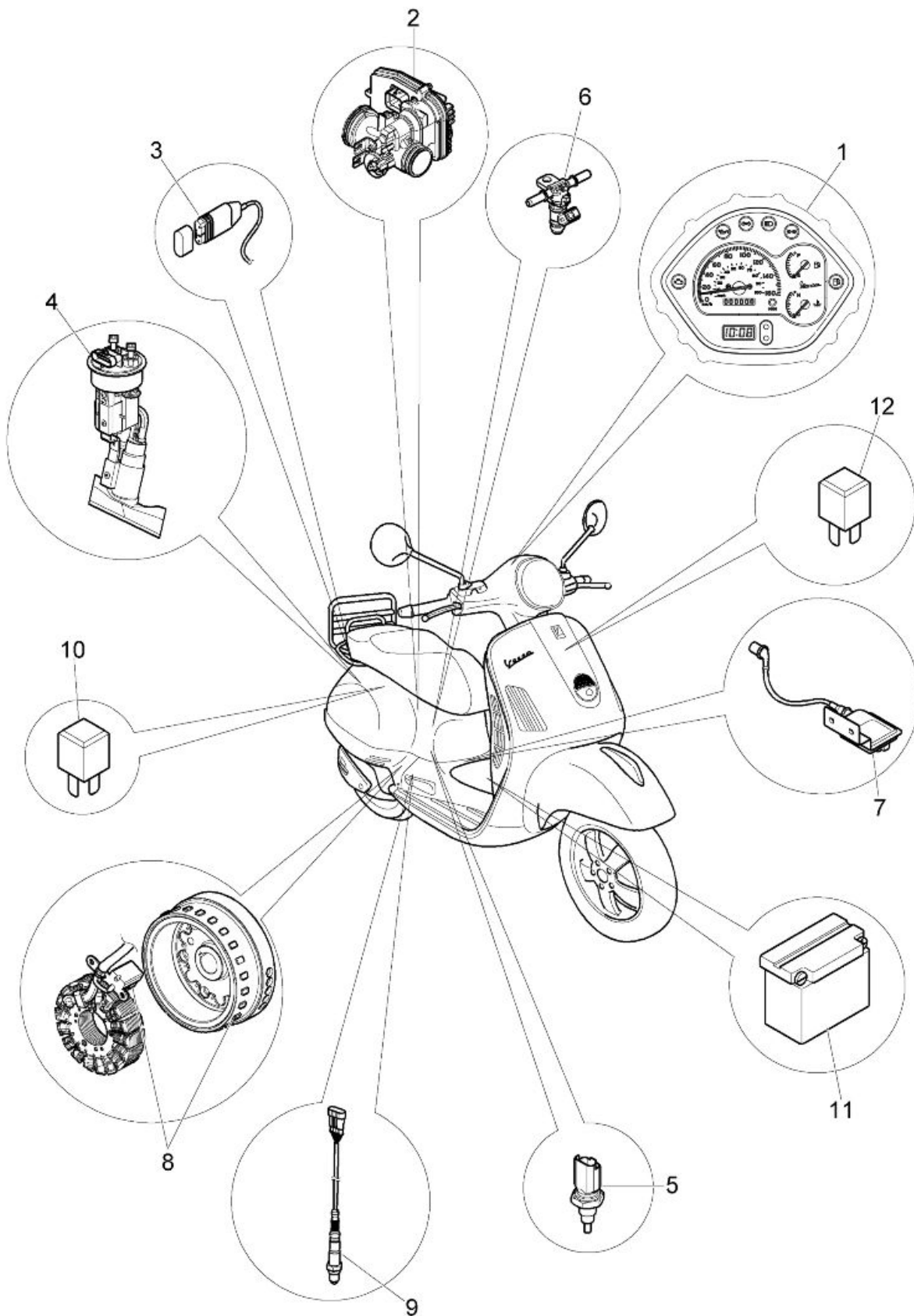

COMPONENT TRANSPOSITION

	Specification	Desc./Quantity
1	Instrument panel	
2	Throttle body and electronic injection control unit (MIU)	
3	Diagnostics socket connector	
4	Fuel pump	
5	Water temperature sensor	
6	Fuel injector	
7	HV coil	
8	Engine rpm sensor	
9	Lambda sensor	
10	Injection load remote control	
11	Battery	12V - 12 Ah
12	Electric fan remote control	

MIU injection system

This vehicle is fitted with an integrated injection and ignition system.

Injection is indirect in the manifold through an electro-injector.

The injection and ignition are timed on the four-stroke cycle by means of a tone wheel keyed on to the crankshaft (24-2 teeth) and pick-up sensor.

Combustion and ignition are managed on the basis of engine revs and throttle valve opening. Further corrections are made according to the following parameters:

- Coolant temperature.
- Intake air temperature
- Lambda probe strength

The system implements an idle feeding correction with cold engine through a Stepper motor on a by-pass circuit of the throttle valve. The control unit manages the Stepper motor and the injector opening time, thereby ensuring the idle steadiness and the proper combustion.

In all conditions of use, mixture preparation is managed by modifying the injector opening time.

The fuel supply pressure is kept constant based on the ambient pressure.

The **fuel supply circuit** consists of:

- Fuel pump
- Fuel filter
- Injector
- Pressure regulator

The pump, the filter and the regulator are placed inside the fuel tank on a single support.

The injector is connected by a pipe with fast-release fittings. The pressure regulator is located at the beginning of the circuit.

The fuel pump is controlled by the MIU control unit ; this ensures the scooter safety

The **ignition circuit** consists of:

- HV coil
- HV cable
- Shielded cap
- MIU control unit

- Spark plug

The MIU control unit manages ignition with the best advance ensuring four-stroke timing (ignition only in the compression phase) at the same time.

The MIU injection-ignition system controls engine functions by means of a pre-set program.

Should any input signals fail, an acceptable working order of the engine is ensured to allow the user to reach a service station.

Of course, this cannot happen when the rpm-timing signal is missing, or when the failure involves the control circuits:

- Fuel pump
- HV coil
- Injector

The control unit is provided with a self-diagnosis system connected to an indicator light in the instrument panel.



Failures are detected and restored by the diagnostic tester.

In any case, when the fault is no longer present, the data storage is automatically cleared after 16 cycles of use (cold start, running at regular engine temperature, stop).

The diagnostic tester is also required to adjust the idle mixture.



Specific tooling

020460Y Scooter diagnosis and tester

The MIU injection-ignition system carries out checks on the rpm indicator and the electric fan for radiator cooling.

The MIU control unit has a decoder for the anti-theft immobilizer system.

The MIU control unit is connected to a diagnostic LED on the instrument panel, that also carries out the deterrent flashing functions.

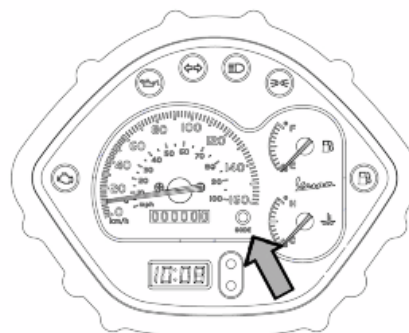

The MIU control unit power supply is furthermore controlled by the emergency switch; that is to provide further safety for the scooter.

Precautions

1. Before fixing any part of the injection system, check to see if there are any registered faults. Do not disconnect the battery before checking for faults.
2. The fuel feed system is pressurised at 250 kPa (2.5 BAR). Before disconnecting the quick coupler of a pipe in the fuel supply system, check that there are no naked flames, and do not smoke. Act with caution to prevent spraying in the eyes.
3. When fixing electric components, operate with the battery connected only when actually required.
4. When functional checks are performed, check that the battery voltage is over 12V.
5. Before trying to start up, check to make sure there is at least two litres of fuel in the tank. Failure to respect this norm will damage the fuel pump.
6. If the scooter is expected to remain unused for a long time, refill the tank up to a little over half the level. This will ensure the pump will be covered by fuel.
7. When washing the vehicle, be careful with the electric components and wiring.
8. When an ignition fault is detected, start the checks from the battery and the injection system connections.
9. Before disconnecting the MIU control unit connector, perform the following steps in the order shown:
 - Set the switch to «OFF»
 - Disconnect the batteryFailure to respect this norm may damage the control unit.
10. Do not invert the polarity when fitting the battery.
11. To avoid damage, only disconnect and reconnect the MIU system connectors if required. Before reconnecting, check that the connectors are dry.
12. When carrying out electric inspections, do not force the tester probes into the connectors. Do not take measurements not specifically foreseen by the manual.
13. At the end of every check performed with the diagnostic tester, protect the system connector with its cap. Failure to do this may damage the MIU control unit.
14. Before reconnecting the quick couplers of the power supply system, check that the terminals are perfectly clean.

Troubleshooting hints

1 A MIU failure is more likely to be due to the connections than to the components.

Before troubleshooting the MIU system, carry out the following checks:

A: Electrical power supply

- a. Battery voltage
- b. Blown fuse

c. Remote controls

d. Connectors

B: Chassis earthing

C: Fuel supply

a. Broken fuel pump

b. Dirty fuel filter

D: Ignition system

a. Faulty spark plug

b. Broken coil

c. Broken shielded cap

E: Intake circuit

a. Dirty air filter

b. Dirty by-pass circuit

c. Faulty Stepper motor

F: Other

a. Incorrect distribution timing

b. Wrong idle mixture

c. Incorrect reset of the throttle valve position sensor

2 MIU system faults may be caused by loose connectors. Make sure that all connections have been correctly made.

Check the connections as follows:

A check that the terminals are not bent.

B check that the connectors have been properly connected.

C check whether the malfunction can be fixed by shaking the connector slightly.

3 Check the entire system before replacing the MIU. If the fault is fixed by replacing the MIU control unit, install the original control unit again and check if the fault occurs again.

4 When troubleshooting use a multimeter with an internal resistance over 10 Ohm /V. Instruments that are not suitable might damage the MIU control unit. Instruments must be used with definitions over 0.1V and 0.5 W , the precision must be greater than 2%.

Terminals setup

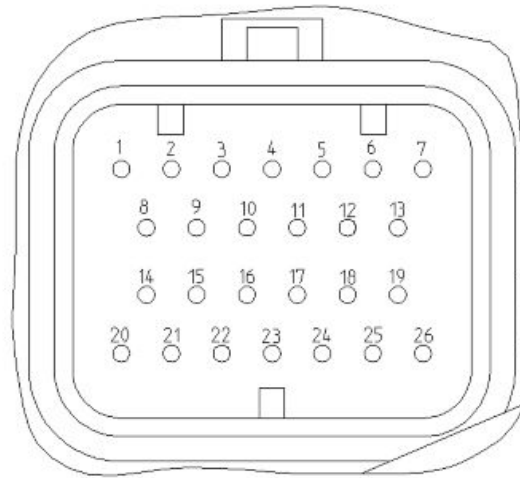

1. Injection warning light
2. incomplete
3. incomplete
4. (-) lambda probe
5. (+) live battery
6. (+) battery
7. Immobilizer aerial
8. Electric fan remote control
9. Water temperature sensor
- 10.incomplete
- 11.(+) lambda probe
- 12.Engine stop switch
- 13.(+) engine rpm sensor
- 14.(-) fuel injector
- 15.(-) engine rpm sensor
- 16.Diagnostics socket output
- 17.Immobilizer LED
- 18.Pin short-circuited with pin 26
- 19.(-) low-beam light automatic turn-on
- 20.(-) injection load remote control
- 21.incomplete
- 22.(-) HV coil
- 23.incomplete
- 24.Start-up enabling
- 25.incomplete

26. Ground lead

EMS circuit diagram

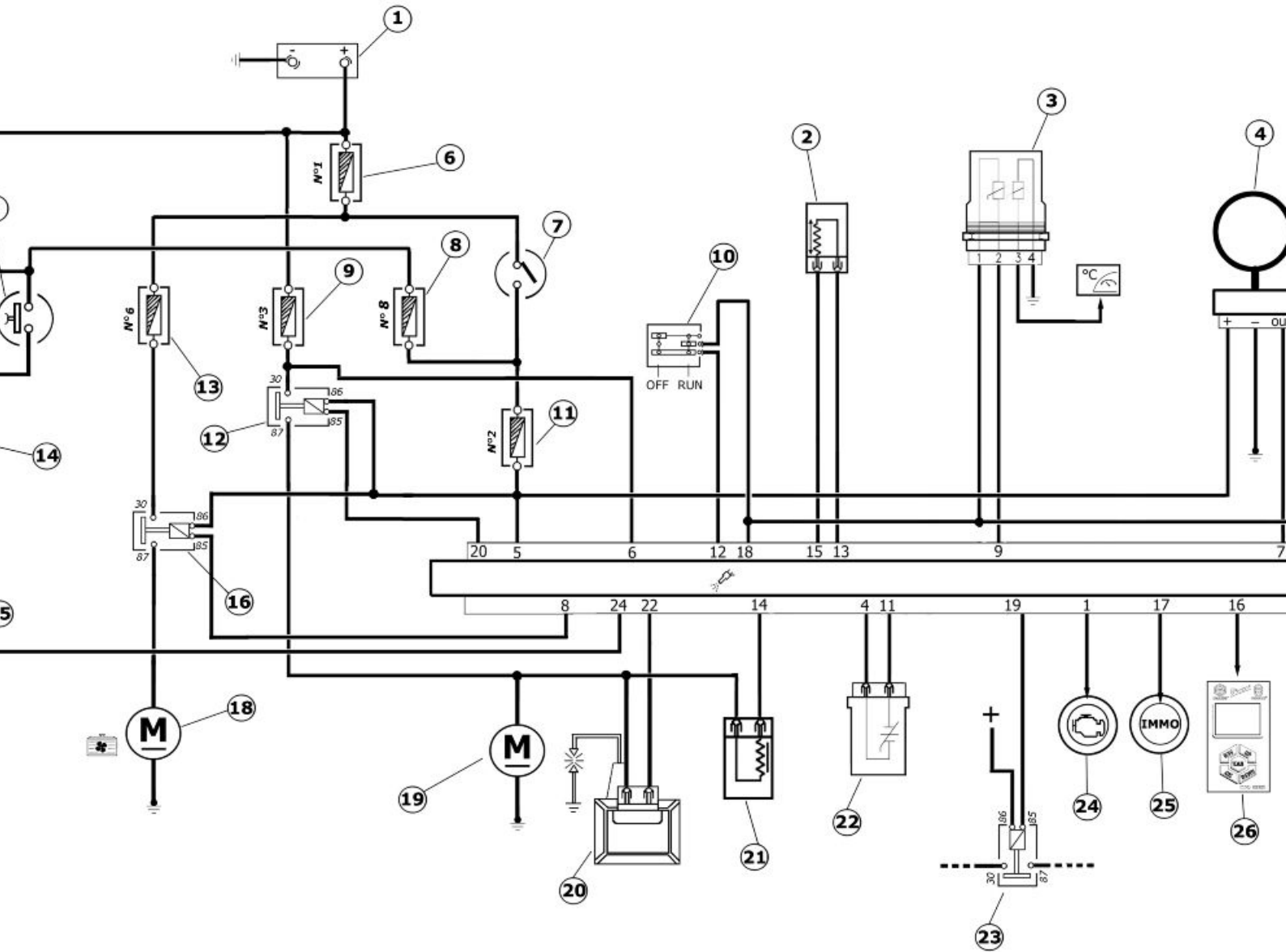

- 1. Battery 12V - 12 Ah
- 2. Rpm sensor
- 3. coolant temperature sensor
- 4. Immobilizer aerial
- 5. Stop switches
- 6. Fuse No. 1; 30A
- 7. Key switch contacts
- 8. Fuse No. 8; 7.5A

- 9. Fuse No. 3; 15A
- 10.Engine stop switch
- 11.Fuse No. 2; 7.5A
- 12.Injection load remote controls
- 13.Fuse No. 6; 15A
- 14.Starter button
- 15.Start-up remote control switch
- 16.Electric fan remote control
- 17.Starter motor
- 18.Electric fan motor
- 19.Fuel pump
- 20.HV coil
- 21.Injector
- 22.Lambda sensor
- 23.Headlight remote control
- 24."WARNING" light
- 25."IMMOBILIZER" led
- 26.Diagnostics socket output

Troubleshooting procedure

Engine does not start

ENGINE DOES NOT START IF ONLY PULLED

Possible Cause	Operation
Immobiliser enabling signal	System not encoded System not efficient, repair according to the indications of the self-diagnosis
Presence of faults detected by the self diagnosis	Pump relay HV coil Injector revolution timing sensor
Fuel supply	Fuel in the tank Fuel pump activation Fuel pressure (low) Injector capacity (low)
Power to the spark plug	Shielded spark-plug cap HV coil (secondary insulation)
Parameter reliability	Coolant temperature Distribution timing - injection ignition Intake air temperature
End of compression pressure	End of compression pressure

Starting difficulties

ENGINE START-UP PROBLEMS

Possible Cause	Operation
Presence of faults detected by the self diagnosis	Pump relay HV coil Injector revolution timing sensor Air temperature Coolant temperature
Start up engine speed	Starter motor and remote control Battery Ground connections
End of compression pressure Power to the spark plug	End of compression pressure Spark plug Shielded cap HV coil Rpm-timing sensor Ignition advance
Fuel supply	Fuel pressure (low) Injector capacity (low) Injector seal (poor)
Correctness of the parameters	Coolant temperature Stepper throttle valve position intake air temperature (steps and actual opening) Cleaning of the auxiliary air pipe and throttle valve; air filter efficiency

Engine stops at idle

ENGINE DOES NOT HOLD IDLING/ IDLING IS UNSTABLE/ IDLING TOO LOW

Possible Cause	Operation
Presence of faults detected by the self diagnosis	Pump relay HV coil Injector revolution timing sensor Air temperature Coolant temperature
Ignition efficiency	Spark plug Ignition timing
Correctness of the parameters	Throttle valve position sensor Stepper Coolant temperature sensor Intake air temperature sensor
Intake system cleaning	Air filter Diffuser and throttle valve Additional air pipe and Stepper
Intake system sealing (infiltrations)	Intake manifold - head Throttle body - manifold Intake sleeve Filter box
Fuel feed (low pressure)	Fuel pump Pressure regulator Fuel filter Injector capacity

Engine does not rev down

ENGINE DOES NOT RETURN TO IDLING SPEED/IDLING SPEED TOO HIGH

Possible Cause	Operation
Presence of faults detected by the self diagnosis	Pump relay

Possible Cause	Operation
	HV coil Injector revolution timing sensor Air temperature Coolant temperature
Ignition efficiency	Ignition timing
Correctness of the parameters	Throttle valve position sensor Stepper Coolant temperature sensor Intake air temperature sensor
Intake system sealing (infiltrations)	Intake manifold - head Throttle body - manifold Intake sleeve Filter box
Fuel feed (low pressure)	Fuel pump Pressure regulator Fuel filter Injector capacity

Exhaust backfires in deceleration

EXHAUST BACKFIRES WHEN DECELERATING

Possible Cause	Operation
Presence of faults detected by the self diagnosis	Pump relay HV coil Injector revolution timing sensor Air temperature Coolant temperature Lambda sensor
Correctness of the parameters	Throttle valve position sensor Stepper Coolant temperature sensor Intake air temperature sensor
Intake system sealing (infiltrations)	Intake manifold - head Throttle body - manifold Intake sleeve Filter box
Fuel feed (low pressure)	Fuel pump Pressure regulator Fuel filter Injector capacity
Exhaust system sealing (infiltrations)	Manifold - head Manifold - muffler Muffler welding

Engine revs irregularly

ENGINE IRREGULAR PERFORMANCE WITH VALVE SLIGHTLY OPEN

Possible Cause	Operation
Intake system cleaning	Air filter Diffuser and throttle valve Additional air pipe and Stepper
Intake system seal	Intake sleeve Filter box
Ignition system	Spark plug wear check
Parameter reliability	Throttle valve position signal Coolant temperature indicator Intake air temperature indicator Ignition advance
TPS reset successful	TPS reset successful
Presence of faults detected by the self diagnosis	Pump relay HV coil

Possible Cause**Operation**

Injector
 revolution timing sensor
 Air temperature
 Coolant temperature
 Lambda sensor

Poor performance at full throttle**POOR ENGINE PERFORMANCE AT FULL POWER/ ENGINE IRREGULAR PROGRESS ON PICKUP****Possible Cause****Operation**

Presence of faults detected by the self diagnosis

Pump relay
 HV coil
 Injector
 revolution timing sensor
 Air temperature
 Coolant temperature
 Lambda sensor

Spark plug power supply

Spark plug
 Shielded cap
 HV cable
 HV coil

Intake system

Air filter
 Filter box (sealing)
 Intake sleeve (sealing)

Parameter reliability

Throttle valve position signal
 Coolant temperature indicator
 Intake air temperature indicator
 Ignition advance

Fuel supply

Fuel level in the tank
 Fuel pressure
 Fuel filter
 Injector capacity

Engine knocking**PRESENCE OF KNOCKING (COMBUSTION SHOCKS)****Possible Cause****Operation**

Presence of faults detected by the self diagnosis

Pump relay
 HV coil
 Injector
 revolution timing sensor
 Air temperature
 Coolant temperature
 Lambda sensor

Ignition efficiency

Spark plug

Parameter reliability

Throttle valve position signal
 Coolant temperature indicator
 Intake air temperature indicator
 Ignition advance

Intake system seal

Intake sleeve
 Filter box

TPS reset successful

TPS reset successful

Fuel supply

Fuel pressure
 Fuel filter
 Injector capacity
 Fuel quality

Selection of the cylinder base gasket thickness

Selection of the cylinder base gasket thickness

Fuel supply system

The fuel supply circuit includes the electric pump, the filter, the pressure regulator, the electro-injector and the fuel delivery pipes.

The electrical pump is located in the tank from which the fuel is pumped and sent to the injector through the filter.

The pressure is controlled by the pressure regulator situated in the pump assembly in the tank.

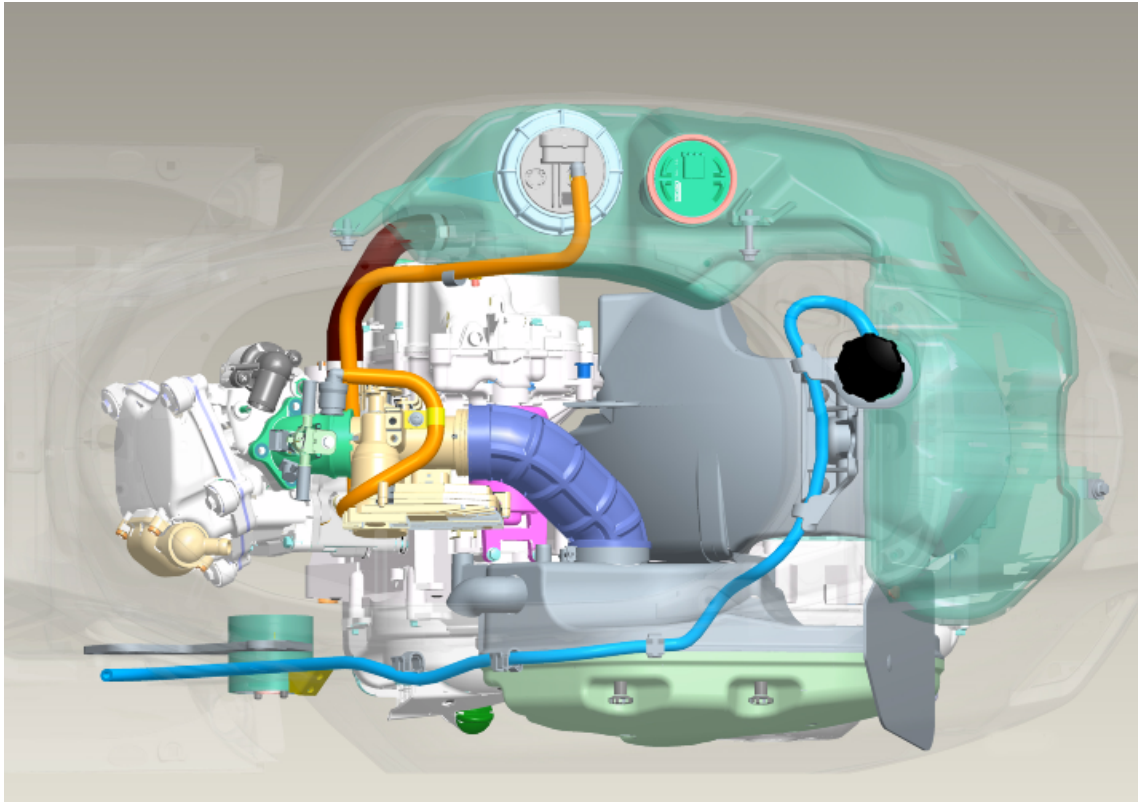

Removing the butterfly valve

Remove the fuel piping clamping screw indicated in the figure.



Remove the fast-release fittings from the injector support.

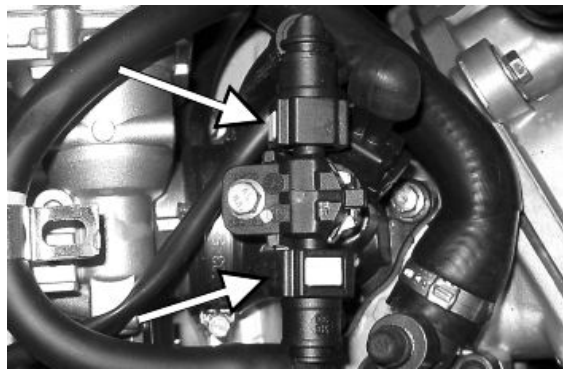

Remove the injector connector.



Remove the three screws fixing the manifold to the cylinder head and the clip fixing the throttle body to the manifold.

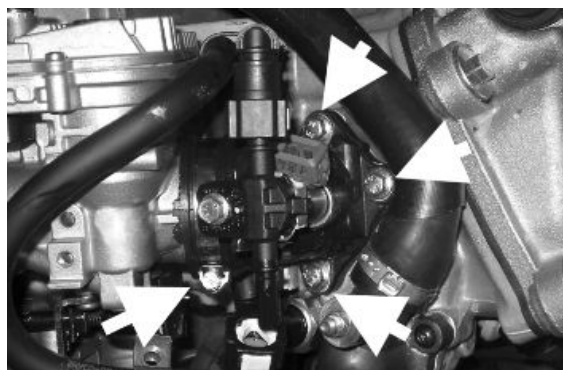

Remove the MIU ECU connector.

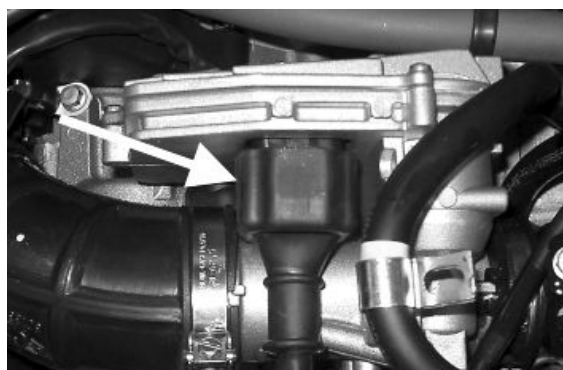

Remove the clip fixing the throttle body to the air cleaner bellows.



Remove the gas command fitting as indicated in the photograph

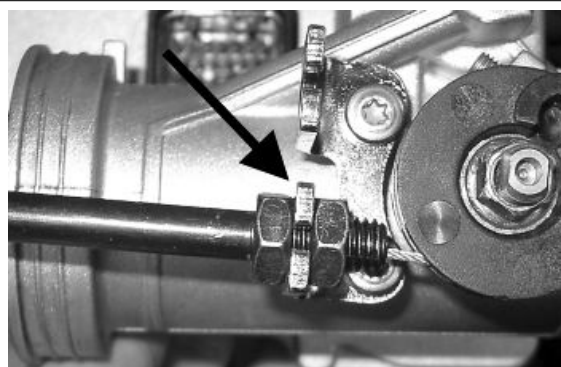

Refitting the butterfly valve

To refit, perform the operations in the reverse order from the removal operations being careful to position the clip fixing the throttle body to the air filter bellows at 45° as shown in the photograph.



Pump supply circuit

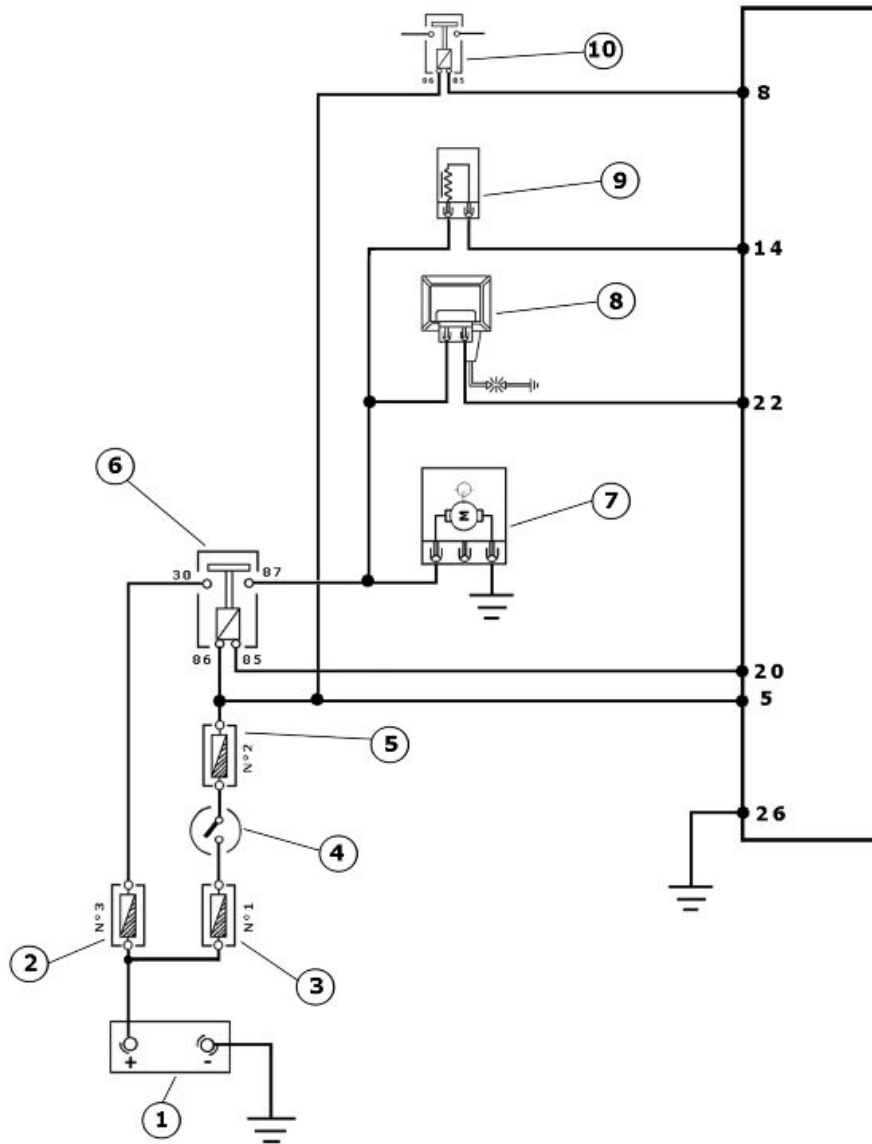

1. Battery 12V
2. Fuse No. 3; 15A
3. Fuse No. 1; 30A
4. Key switch contacts
5. Fuse No. 2; 7.5A
6. Injection load remote control
7. Fuel pump
8. HV coil

9. Fuel injector

10. Electric fan remote control

When switched to "ON", the fuel pump starts to rotate for two seconds and then stops. When the engine starts up, in the presence of rpm timing signal the pump is continuously supplied.

ELECTRICAL DATA

- Pump winding resistance ~ 1.5 Ohm
- Input current during normal functioning $1.4 \div 1.8$ A
- Input current to the closed hydraulic circuit ~ 2 A (to be checked with specific tool for fuel pressure control, choking the circuit on the return pipe)

Check that the injection load 15A fuse No. 3 works properly.

Check that the 7.5A fuse No. 2 for live control unit power works properly.

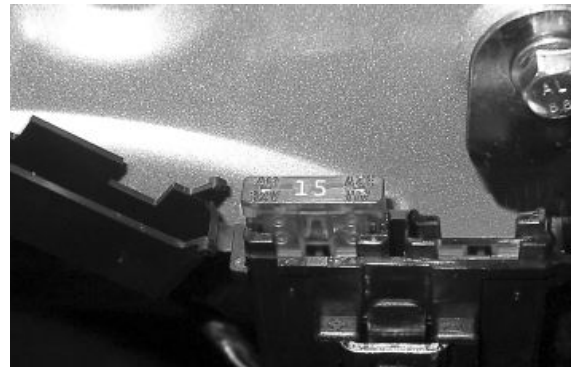

Check the efficiency of the injection load remote control: Check the resistance of the energising coil between pins 86 and 85: 40 to 80 Ohm

Apply a voltage of 12V to pins 86 and 85; make sure that there is continuity between pins 30 and 87 of the remote control.



Check the power supply line of the injection load remote control energising coil: after switching to "ON", make sure there is battery voltage, for two seconds, between the Red-White cable and Black-Purple cable of the remote control base. If there is not, check the continuity of the Red-White cable between the fuse box under the saddle hinge and the remote control base and of the Black-Purple cable between pin 20 of the control unit and the remote control base.



N.B.

CONTINUITY TESTS MUST BE CARRIED OUT WITH THE COMPONENTS DISCONNECTED. (REMOTE CONTROLS, CONTROL UNIT, FUSES ETC.).

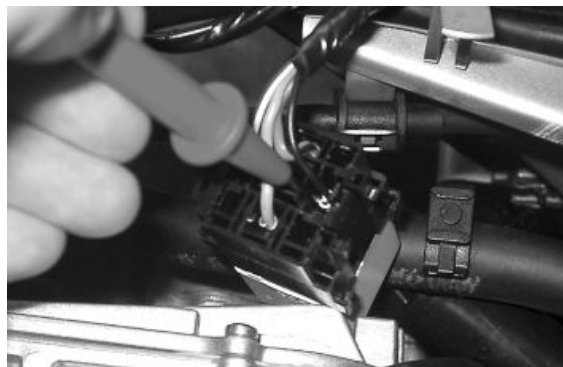
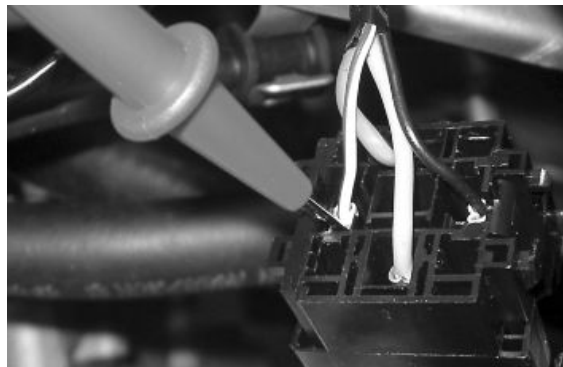

Check the presence of fixed voltage between the grey/black cable of the remote control base and earth. If there is none, check the continuity of the grey/black cable between the fuse box (No. 3 15 A) and the remote control base.

N.B.

CONTINUITY TESTS MUST BE CARRIED OUT WITH THE COMPONENTS DISCONNECTED. (REMOTE CONTROLS, CONTROL UNIT, FUSES ETC.).

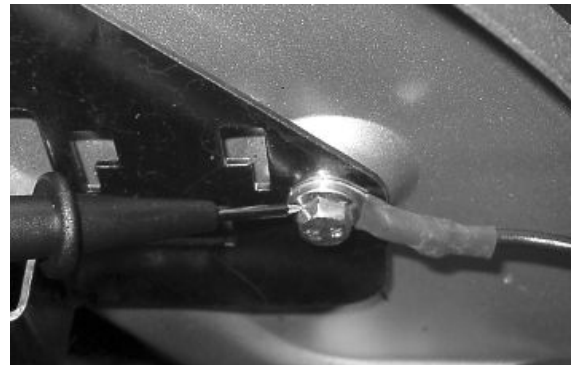
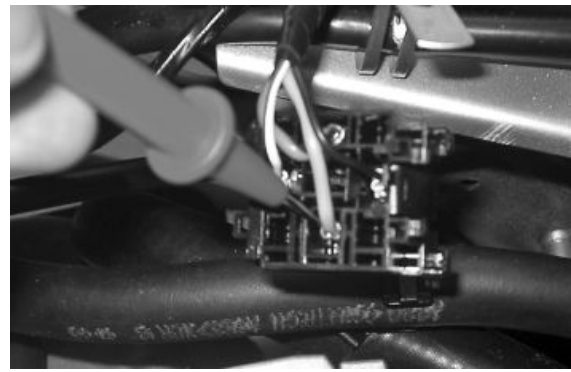

pump circuit 6

Check, on switching to "ON", that there is battery voltage, for about two seconds, to the Black-Green cable of the pump connector and earth with pump connector disconnected. Otherwise, check the continuity of the Black-Green cable between the pump connector and the remote control base. Check the efficiency of the earth line of the fuel pump by measuring the continuity between the pump connector black cable, system side, and the earth.

If, when switching to "ON", the pump continues to turn after two seconds of activation, check, with the control unit disconnected and the injection load re-

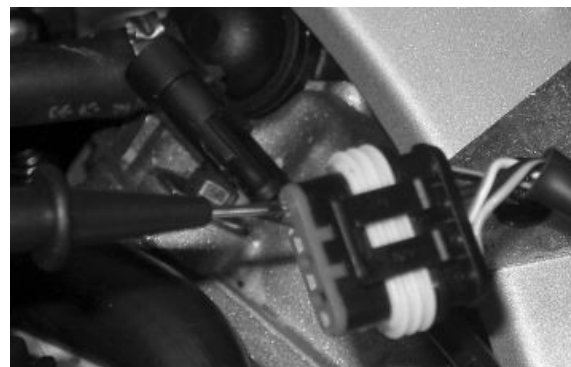

mote control disconnected, that the Black-Purple cable (pin 20 on the interface wiring) is insulated from the earth.

Specific tooling

020331Y Digital multimeter

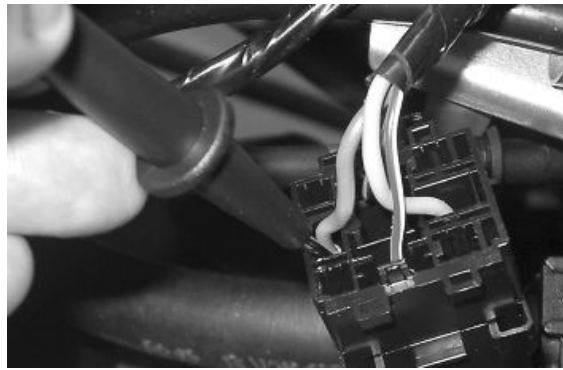

Circuit leak test

Install the specific tool for checking the fuel pressure, with the pipe fitted with the gauge.

Check during regular operation by placing the appropriate tool between the pump and the injector. With the battery voltage > 12 V check that the fuel pressure is 2.5 BAR and that the input current is 1.4 to 1.8 A



With the battery voltage > 12 V, check the pump flow rate by disconnecting from the injector the pipe equipped with the pressure gauge of the appropriate tool. Make a graded burette available with a flow rate of approximately 1 L. Rotate the pump using the active diagnosis of the palm top computer. Using a pair of long flat needle-nose pliers, choke the fuel pipe making the pressure stabilise at approx. 2.5 BAR. Check that, in fifteen seconds, the pump has a flow rate of around 110 cm³.

Specific tooling

020480Y Petrol pressure check set

Fuel filter check

Disconnect the terminals from the electric pump



Remove the screw shown in the photograph

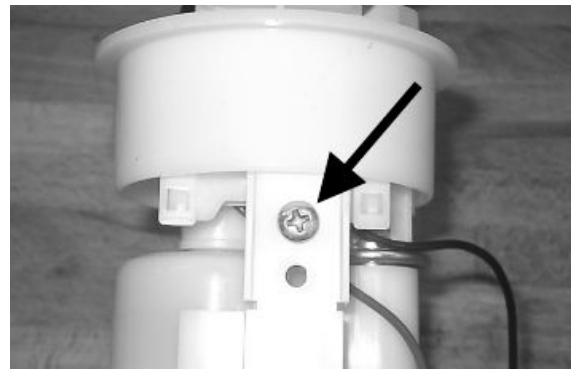

Remove the clip fixing the piping to the filter shown in the photograph



Separate the lower part of the pump support as shown in the photograph.

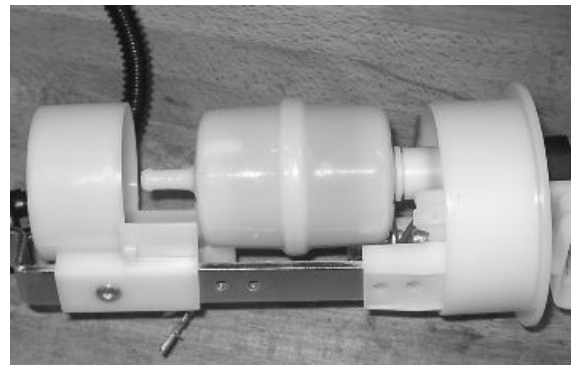

Remove the filter from the pump support



Inspecting the injector circuit

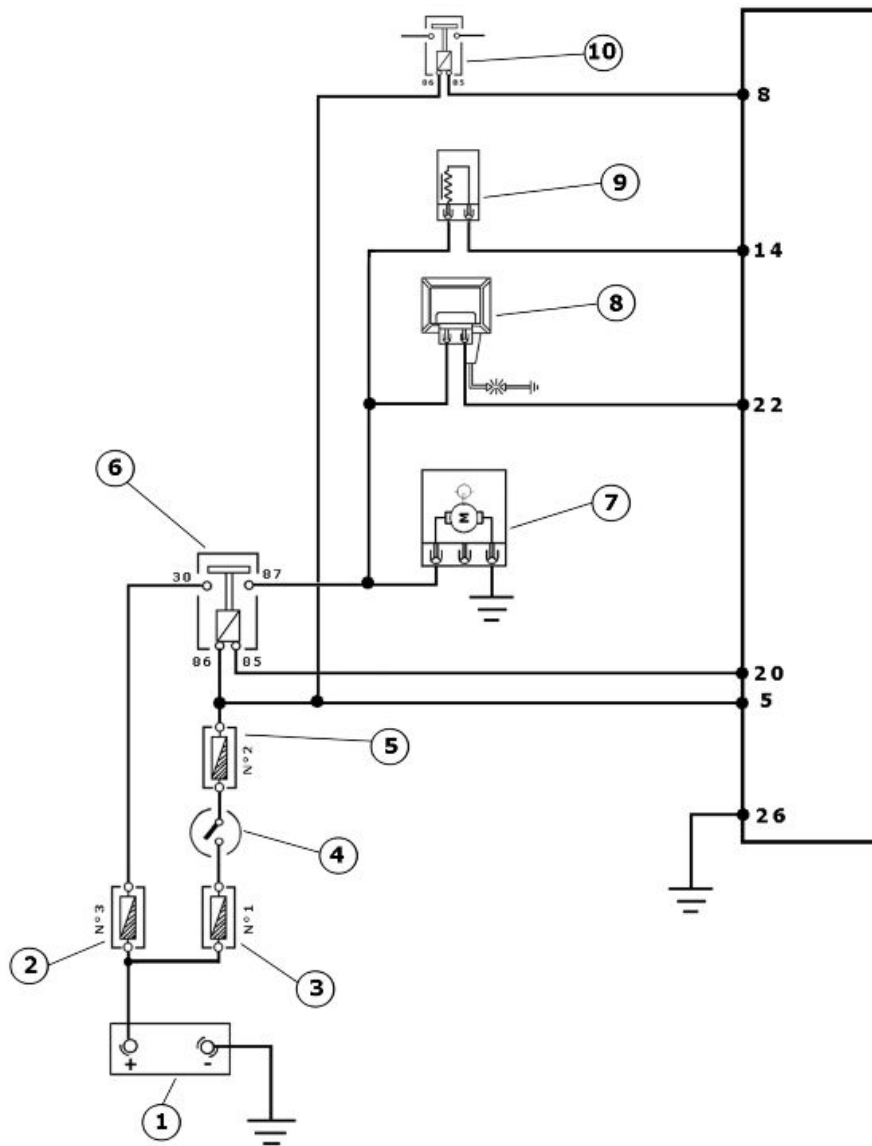

1. Battery 12V
2. Fuse No. 3; 15A
3. Fuse No. 1; 30A
4. Key switch contacts
5. Fuse No. 2; 7.5A
6. Injection load remote control
7. Fuel pump
8. HV coil

9. Fuel injector

10. Electric fan remote control

Check the resistance at the injector ends: $14.5 \pm 5\%$ Ohm

Check that the injection load 15A fuse No. 3 works properly.

Check that the 7.5A fuse No. 2 for live control unit power works properly.

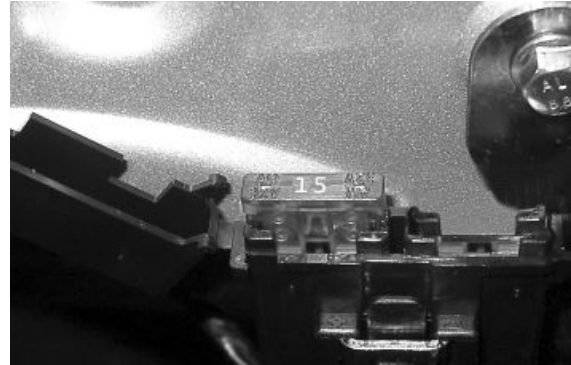

Check the efficiency of the injection load remote control: Check the resistance of the energising coil between pins 86 and 85: 40 to 80 Ohm

Apply a voltage of 12V to pins 86 and 85; make sure that there is continuity between pins 30 and 87 of the remote control.



Check the power supply line of the injection load remote control energising coil: after switching to "ON", make sure there is battery voltage, for two seconds, between the Red-White cable and Black-Purple cable of the remote control base. If there is not, check the continuity of the Red-White cable between the fuse box under the saddle hinge and the remote control base and of the Black-Purple cable between pin 20 of the control unit and the remote control base.

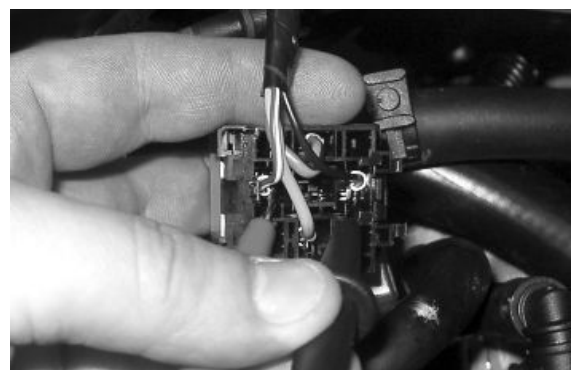

N.B.

CONTINUITY TESTS MUST BE CARRIED OUT WITH THE COMPONENTS DISCONNECTED. (REMOTE CONTROLS, CONTROL UNIT, FUSES ETC.).

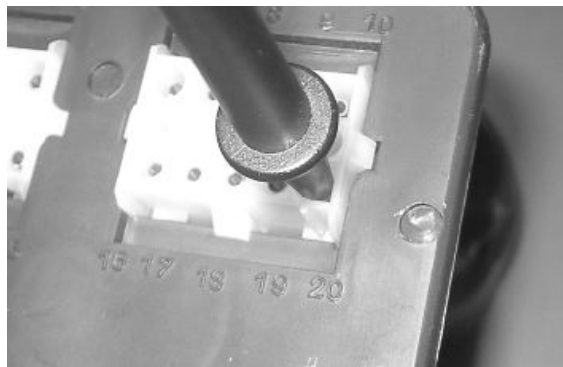
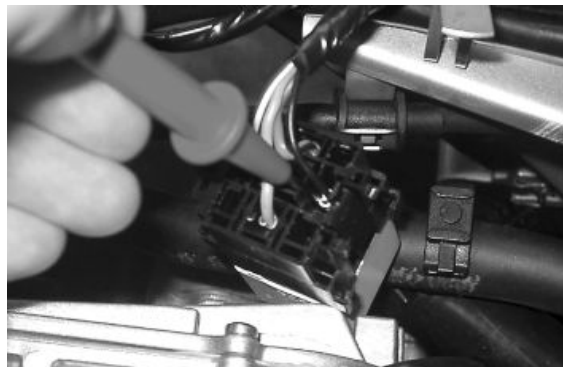
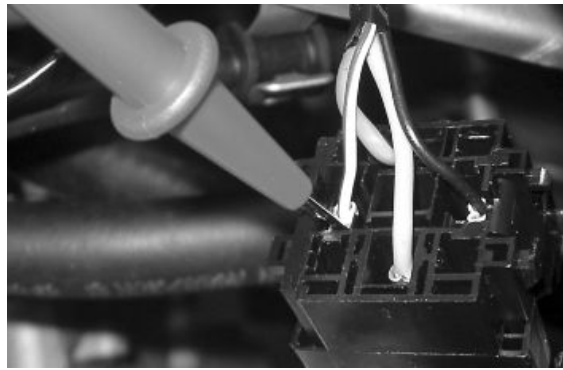

Check the presence of fixed voltage between the grey/black cable of the remote control base and earth. If there is none, check the continuity of the grey/black cable between the fuse box (No. 3 15 A) and the remote control base.

N.B.

CONTINUITY TESTS MUST BE CARRIED OUT WITH THE COMPONENTS DISCONNECTED. (REMOTE CONTROLS, CONTROL UNIT, FUSES ETC.).

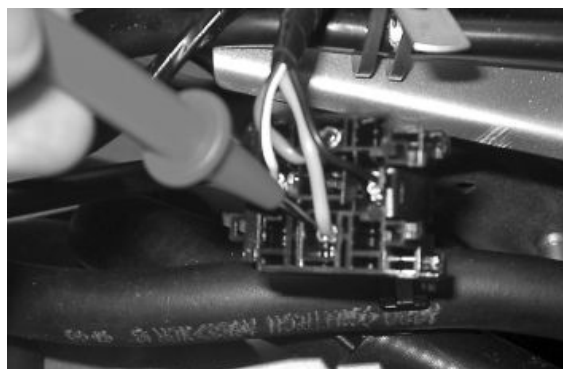

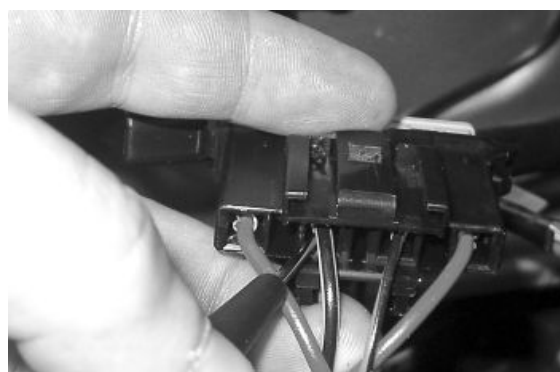
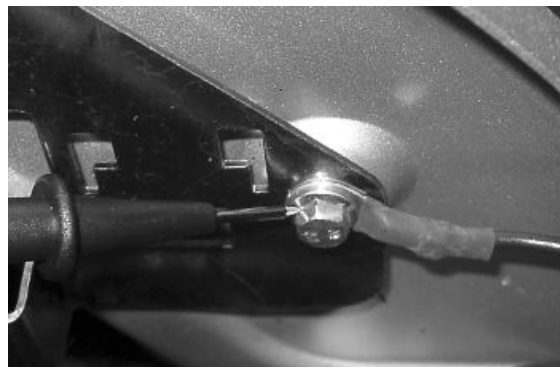

With the control unit and the injector disconnected, check the continuity of the Red-Yellow cable between pin 14 of the interface wiring and the injector connector

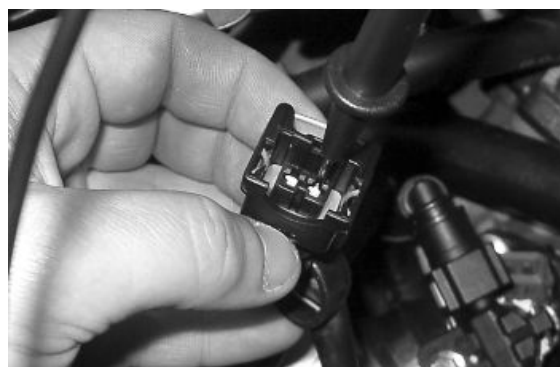

Switch to «ON» and check if there is voltage, with injector disconnected and control unit connected, between the Black-Green cable of the injector connector and the ground lead



With injector disconnected and the injector load remote control disconnected, check the continuity of the Black-Green cable between the injector connector and remote control base.

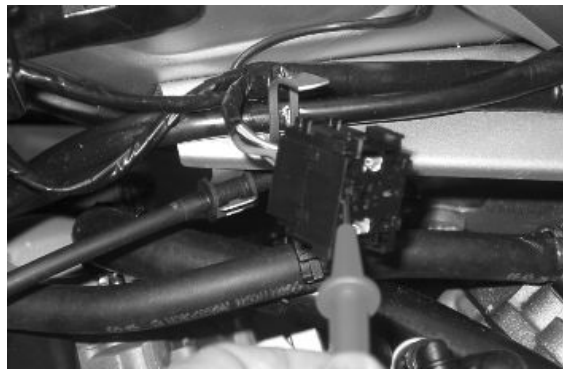

Inspecting the injector hydraulics

To carry out the injector check, remove the intake manifold by removing the three clamping screws at the head and the clip connecting the control unit to the manifold.



Install the appropriate tool for checking fuel pressure and position the manifold over a container graduated by at least 100 cm³. Connect the injector with the cable making up part of the supply for the injection tester. Connect the clamps of the cable to an auxiliary battery. Activate the fuel pump with the active diagnosis. Check that, within fifteen seconds, approximately 40 cm³ of fuel is dispensed with an adjustment pressure of approximately 2.5 BAR.



Specific tooling

020480Y Petrol pressure check set



Proceed with the injector seal test.

Dry the injector outlet with a blast of compressed air. Activate the fuel pump. Wait for one minute, making sure there are no leaks coming from the injector. Slight oozing is normal.

Value limit = 1 drop per minute



Components location

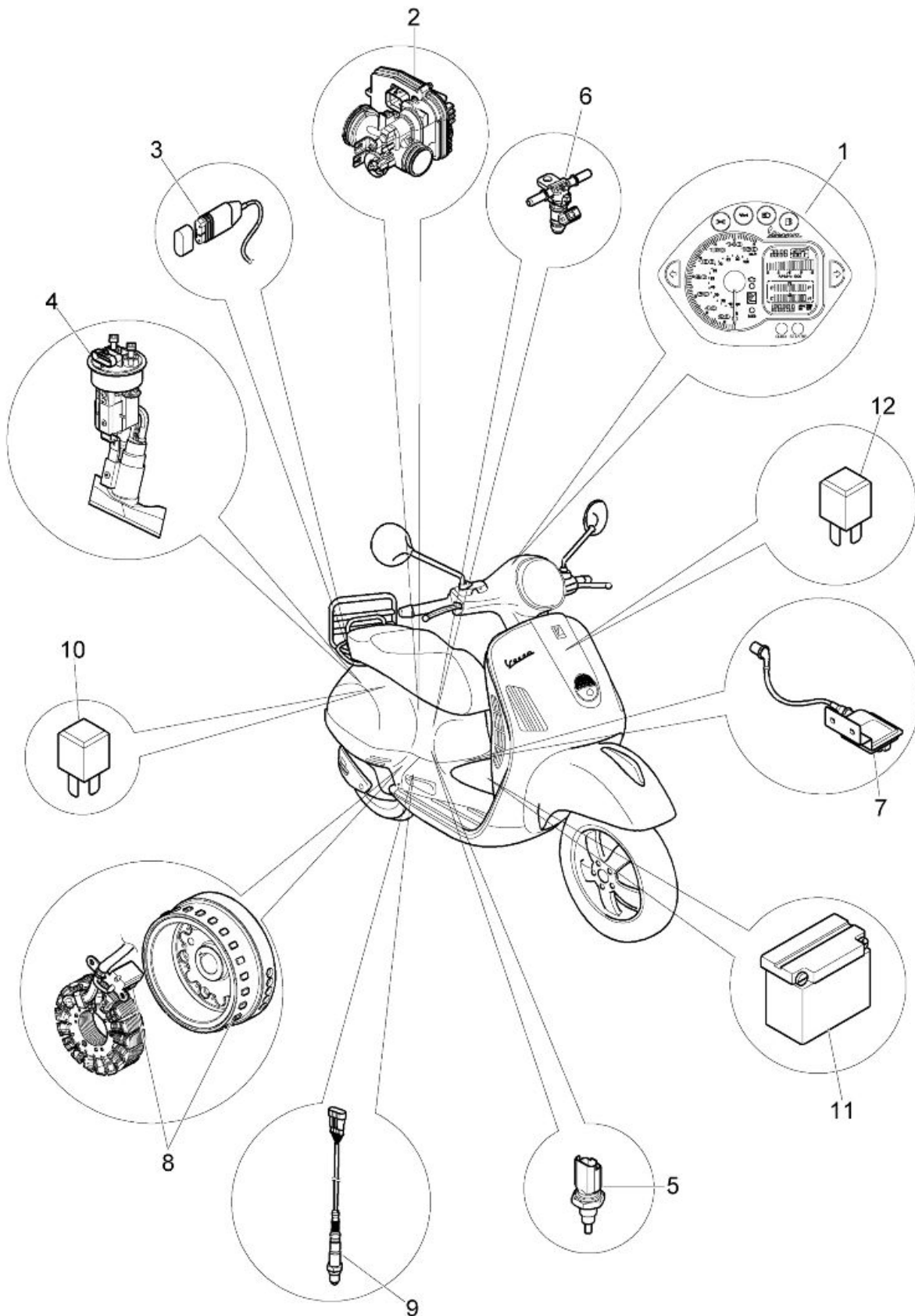

COMPONENT LAYOUT

	Specification	Desc./Quantity
1	Instrument panel	
2	Throttle body and electronic injection control unit (MIU)	
3	Diagnostic socket	
4	Fuel pump	
5	Water temperature sensor	
6	Fuel injector	
7	HV coil	
8	Flywheel - rpm timing sensor	
9	Lambda sensor	
10	Injection load remote control	
11	Battery	12V - 12 Ah
12	Electric fan remote control	

Tachometer

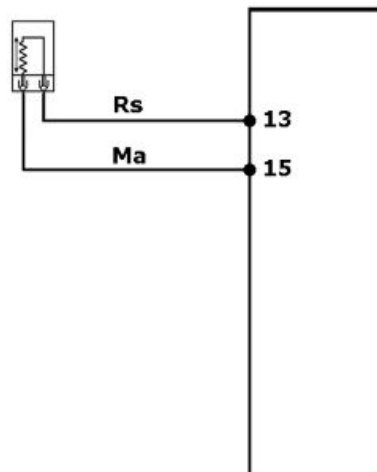

With wiring disconnected from the control unit and connected to the system, check that the sensor resistance between pins 13 - 15 is between 100 and 150 Ohm at an engine temperature of approximately 20°

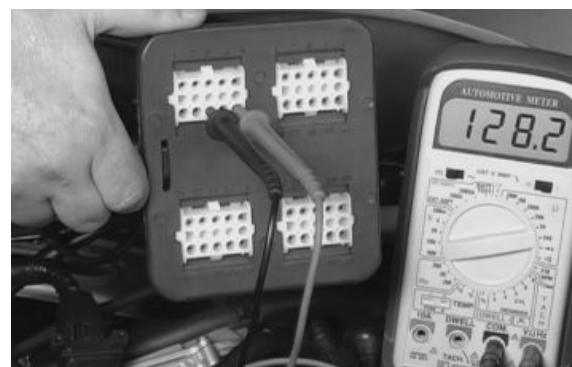

Disconnect the fuel pipe connector. Start up the engine and wait for it to stop. With the wiring connected to the control unit and system try to start up the engine and check that the voltage between pins 13 and 15 is around 2.8 V

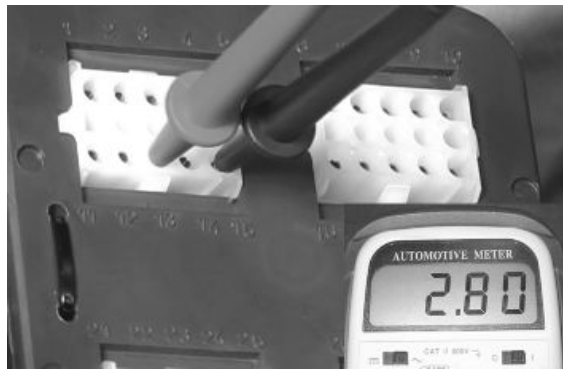

With the interface cable harness disconnected from the control unit, check continuity between pin 13 and the red cable of the rpm sensor connector and between pin 15 and the brown cable of the rpm sensor connector

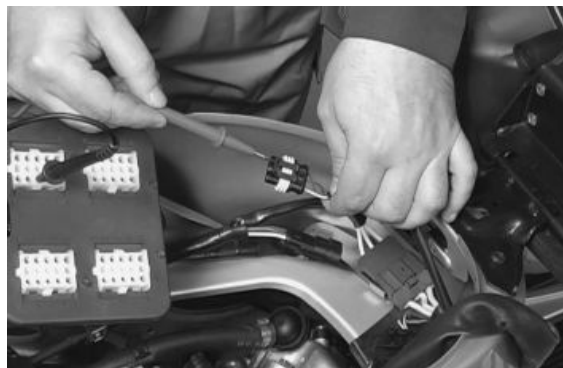

With the interface wiring disconnected from the control unit and rpm sensor connector, check that the red and brown cables (pin 13 - 15) are isolated from each other and insulated from the earth.

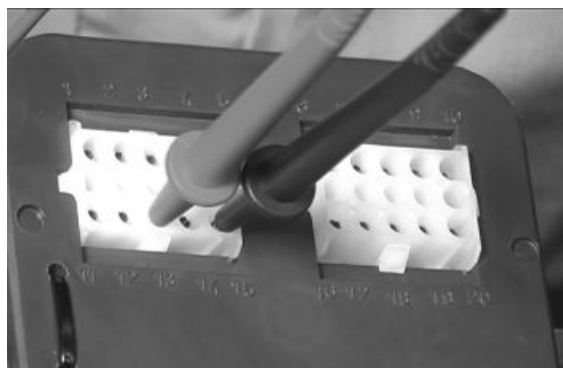

Specific tooling

020481Y Control unit interface wiring

020331Y Digital multimeter

9. Fuel injector

10. Electric fan remote control

The ignition system is integrated with the injection and it is a high-efficiency inductive type ignition.

The control unit manages two important parameters:

- Ignition advance

This is optimised according to the engine rpm, to the engine load, temperature and ambient pressure

With idle engine, it is optimised to obtain the stabilisation of the speed at 1450 ± 50 R/1'.

- Magnetisation time

The coil magnetisation time is controlled by the control unit. The ignition power is increased during the engine start-up.

The injection system recognises the 4-stroke cycle and therefore, ignition is only controlled during compression.

Specific tooling

020331Y Digital multimeter

Check that the injection load 15A fuse No. 3 works properly.

Check that the 7.5A fuse No. 2 for live control unit power works properly.

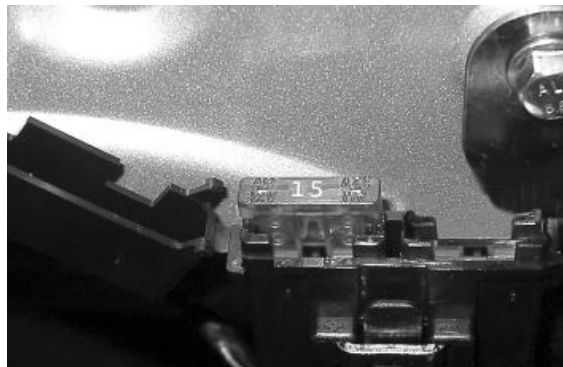

Check there is voltage between pins 22 and 26 of the interface wiring for around two seconds when switching to «ON».

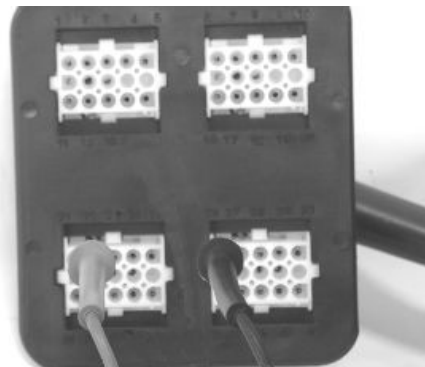

Check the resistance of the primary coil between pin 22 of the interface wiring and the green black cable of the injection load remote control base with the control unit disconnected and the remote control disconnected.

Resistance of the primary = $0.5 \pm 8\%$ Ohm

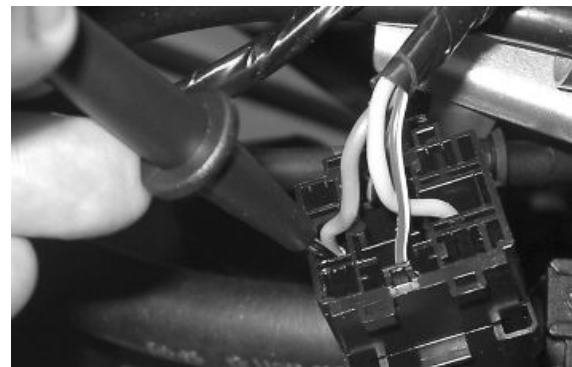
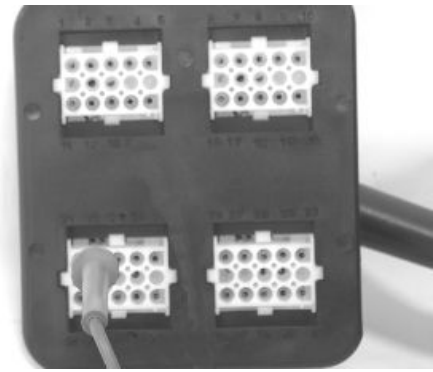

Check the efficiency of the injection load remote control: Check the resistance of the energising coil between pins 86 and 85: 40 to 80 Ohm

Apply a voltage of 12V to pins 86 and 85; make sure that there is continuity between pins 30 and 87 of the remote control.

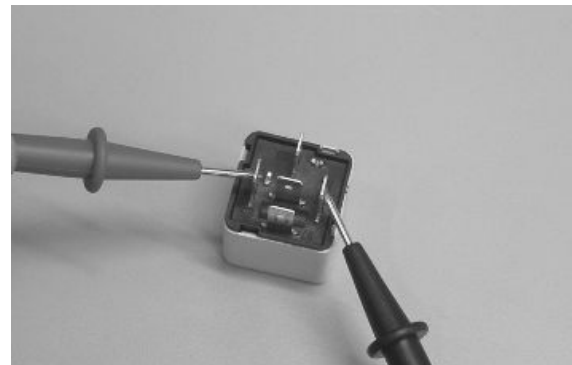

Check the power supply line of the injection load remote control energising coil: after switching to "ON", make sure there is battery voltage, for two seconds, between the Red-White cable and Black-Purple cable of the remote control base. If there is not, check the continuity of the Red-White cable between the fuse box under the saddle hinge and the remote control base and of the Black-Purple cable between pin 20 of the control unit and the remote control base.

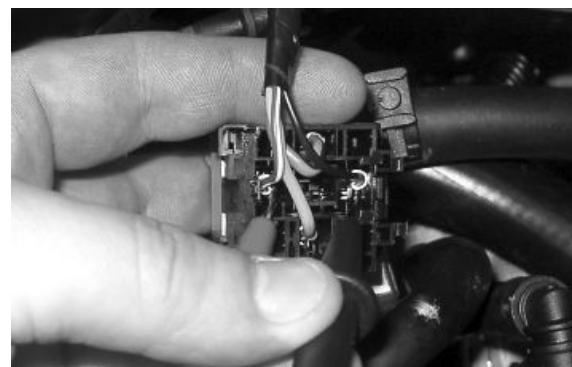

N.B.

CONTINUITY TESTS MUST BE CARRIED OUT WITH THE COMPONENTS DISCONNECTED. (REMOTE CONTROLS, CONTROL UNIT, FUSES ETC.).

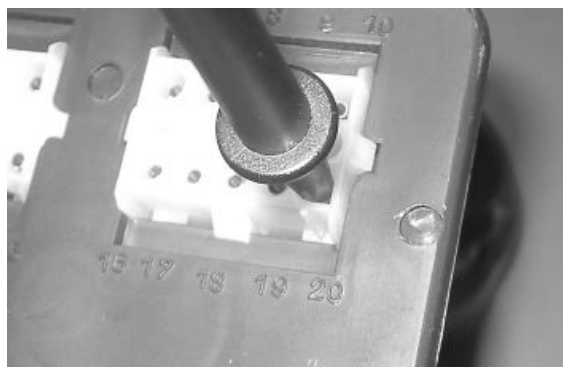
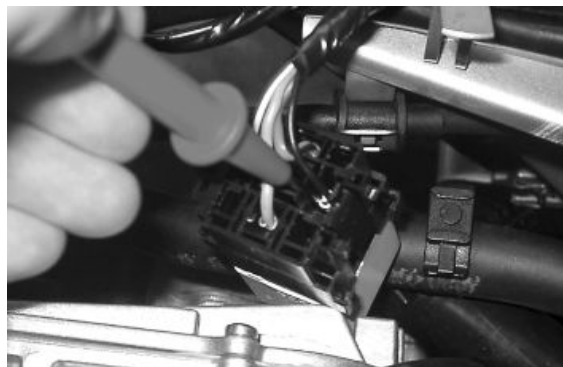
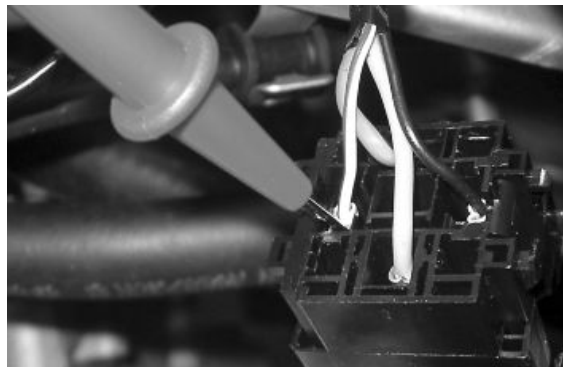

Check the presence of fixed voltage between the grey/black cable of the remote control base and earth. If there is none, check the continuity of the grey/black cable between the fuse box (No. 3 15 A) and the remote control base.

N.B.

CONTINUITY TESTS MUST BE CARRIED OUT WITH THE COMPONENTS DISCONNECTED. (REMOTE CONTROLS, CONTROL UNIT, FUSES ETC.).

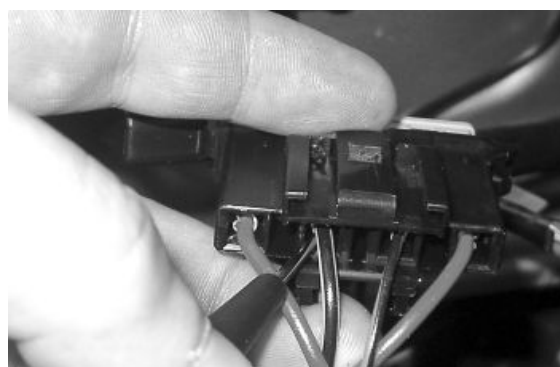
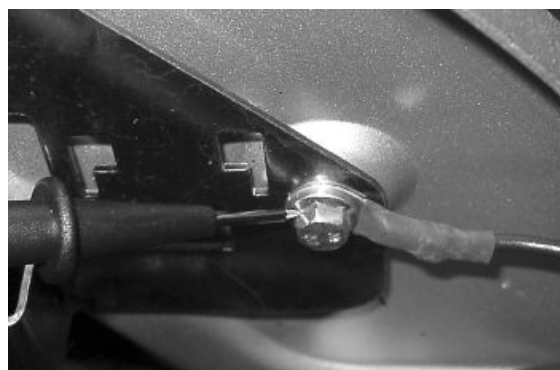
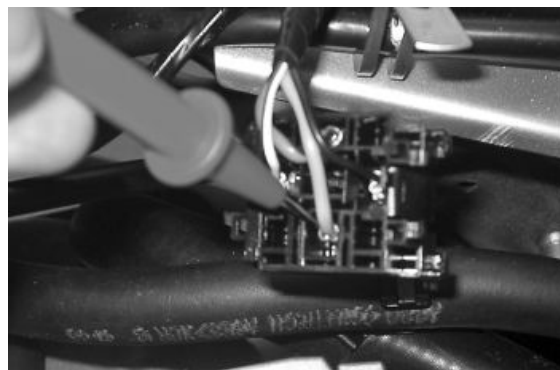

Coolant temperature sensor

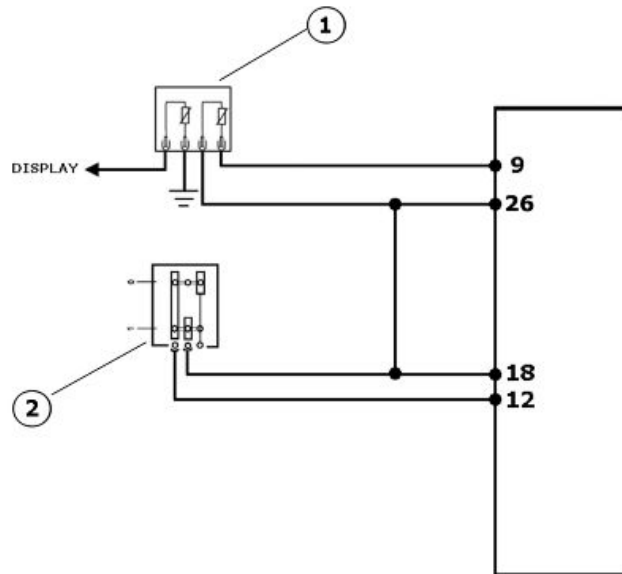

TEMPERATURE SENSOR 1

	Specification	Desc./Quantity
1	Water temperature sensor	
2	Engine stop switch	

With the connector on the control unit side disconnected, and the coolant temperature sensor connector connected, check that the resistance values between pins 9 and 18 correspond to the engine temperature.

20° = 2500 ± 100 Ω

80° = 308 ± 6 Ω

With the control unit side connector disconnected, and the coolant temperature connector disconnected, check the insulation between the two light blue-green and grey-green cables

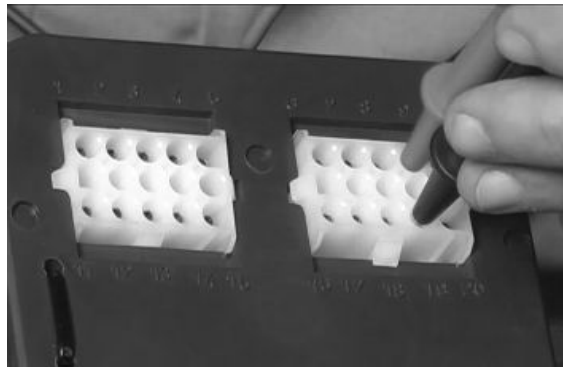

With the control unit side connector disconnected, and the coolant temperature sensor connector disconnected, check the continuity between pin 9 of the interface wiring and the light blue-green cable of the connector, and between pin 26 of the interface wiring and the grey-green cable of the connector.

Specific tooling

020481Y Control unit interface wiring

020331Y Digital multimeter

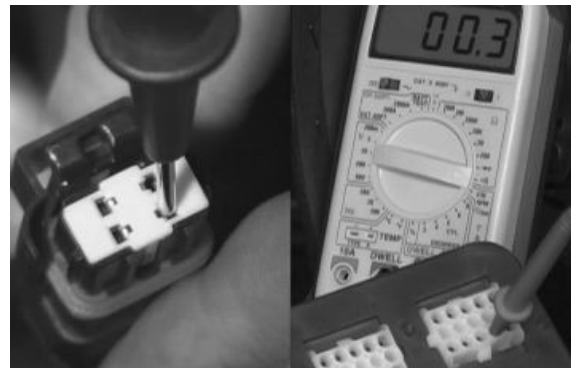

Zeroing the throttle

Resetting the throttle valve position signal (TPS reset)

The MIU control unit is supplied with a throttle valve position sensor that is pre-calibrated.

Pre-calibration entails regulating the minimum opening of the throttle valve to obtain a certain flow of air under pre-set reference conditions.

Pre-calibration ensures optimal air flow to control idling.

This regulation must not be tampered with in any way whatsoever.

The injection system will complete the management of the idling through the Stepper motor and the variation of the ignition advance.

The throttle body after the pre-calibration has an opened valve with an angle that can vary depending on the tolerances of the machining of the pipe and the valve itself.

The valve position sensor can also assume various fitting positions. For these reasons the mV of the sensor with the valve at idle can vary from one throttle body to another.

To obtain the optimum fuel mixture, especially at small openings of the throttle valve, it is essential to match the throttle body with the control unit following the procedure known as TPS resetting.

With this operation we inform the control unit, as the starting point, of the mV value corresponding to the pre-calibrated position.

To reset, proceed as follows.

Connect the diagnostic tester.

Switch to «ON».

Select the functions of the diagnostic tester on
«TPS RESET».

Specific tooling

020460Y Scooter diagnosis and tester



Make sure that the throttle valve with the control is supporting the stop screw.

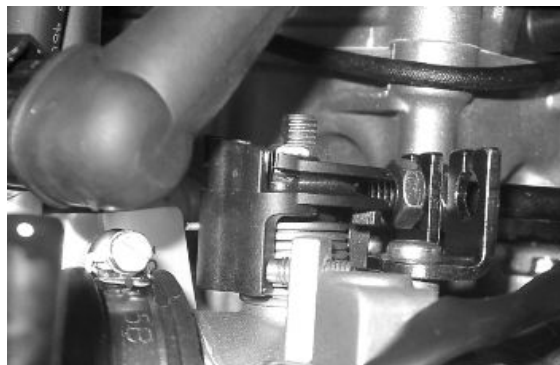

Guaranteeing that this position will be kept, send a confirmation for the TPS reset procedure.





Reset should be performed in the following cases:

- on first fitting.
- if the injection control unit is replaced.

N.B.

THE TPS RESETTING PROCEDURE MUST NOT BE CARRIED OUT WITH A USED THROTTLE BODY BECAUSE POSSIBLE VALVE WEAR AND STOP WEAR FOR THE MINIMUM OPENING MAKE THE AIR FLOW DIFFERENTLY FROM THAT OF PRE-CALIBRATION.

Given that the TPS resetting is also done when the control unit is replaced, place the control unit - filter box bellows at 45° during the refitting operation as shown in the photograph.



Lambda probe

SIGNAL CONTROL

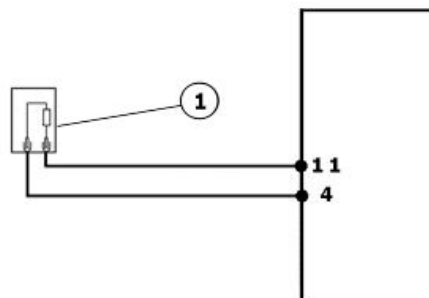

1. Lambda probe

Install the electronic control unit interface wiring.
Start the engine and warm up until the electric fan switches on.

Use an analogue multimeter with a direct voltage scale measuring down to 2 V.

Place the tips of the multimeter between pins 4 (-) and 11 (+)

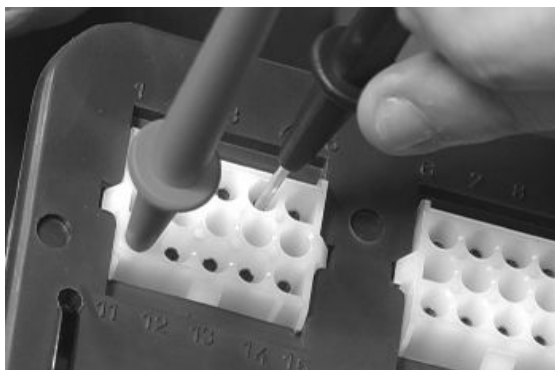

With the engine running at idle speed, check that the voltage oscillates between 0V and 1V

With the throttle valve completely open, the voltage is approx. 1V.

During the closing phase, the voltage is approx. 0V.

If the voltage remains constant, the sensor may be damaged. Remove the sensor and check that there are no oil or carbon deposits inside it..



Impianto elettroventilatore

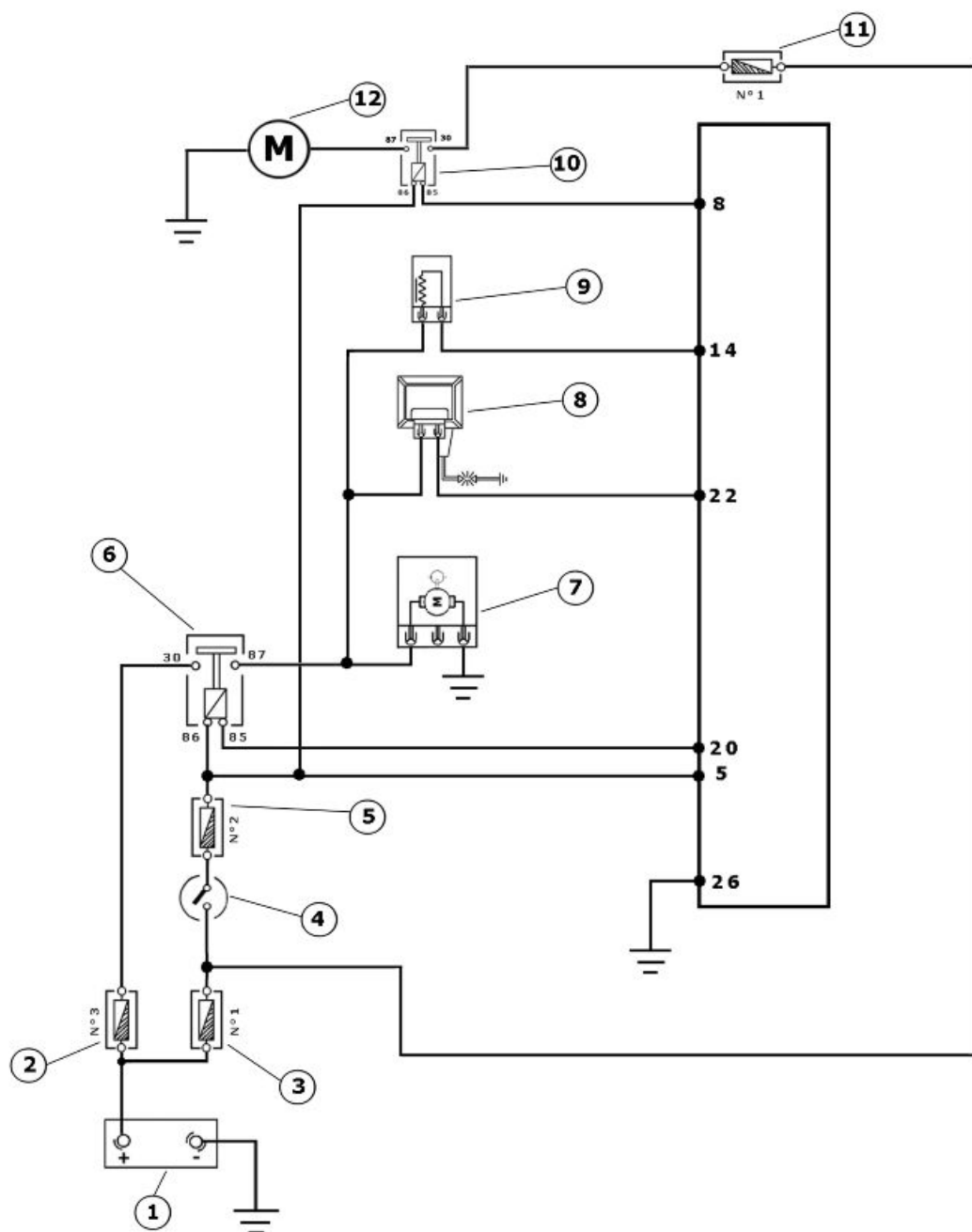

1. Battery 12V
2. Fuse No. 3; 15A
3. Fuse No. 1; 30A
4. Key switch contacts
5. Fuse No. 2; 7.5A
6. Injection load remote control
7. Fuel pump

8. HV coil
9. Fuel injector
10. Electric fan remote control
11. Fuse No. 6; 15A
12. Electric fan motor

Check that the 7.5A fuse No. 2 works properly



With the key switch set to ON, check if there is +12 V battery voltage between the RED - WHITE cable of the electric fan remote control and the ground connection.

Check if the RED - WHITE cable between the fuse box (under the saddle) and the electric fan remote control base is not interrupted

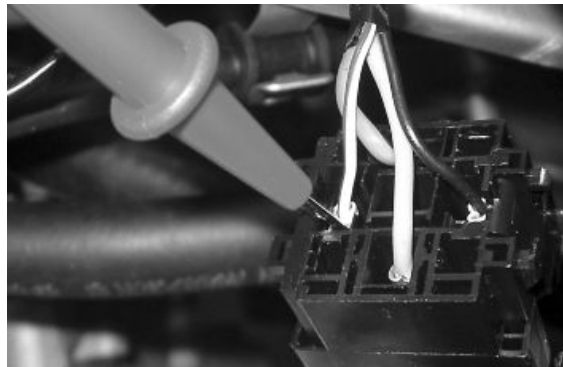

Using a diagnosis hand-held computer, carry out an active diagnosis for the "ELECTRIC FAN".

Check if there is battery voltage at pins 85 - 86 of the electric fan remote control

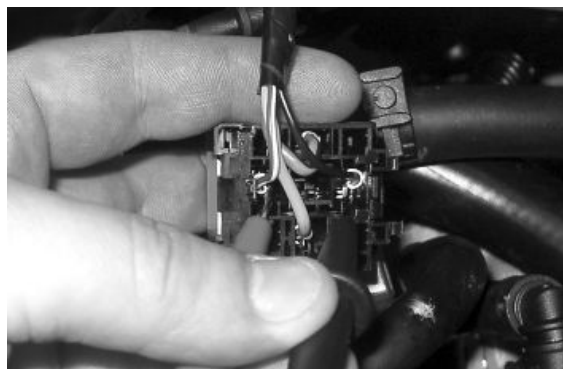

Check if the BLUE - YELLOW cable between the control unit pin 8 and the electric fan remote control base is not interrupted

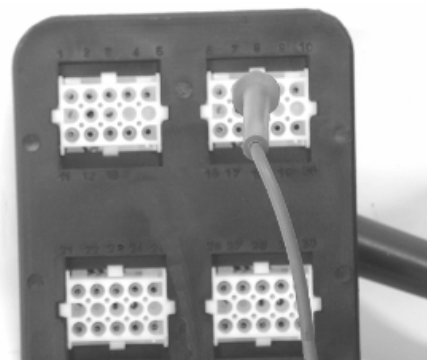

Check the 15A Fuse No. 6

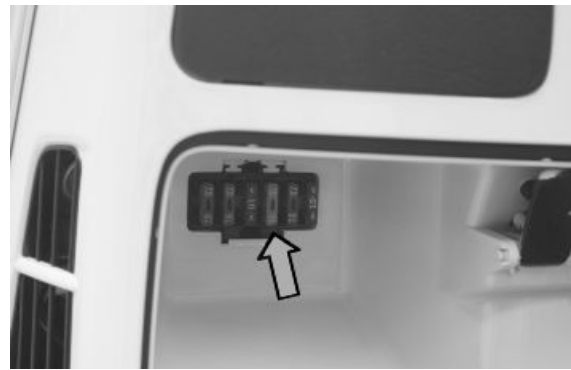

Check if there is +12 V voltage between the GREY cable of the electric fan remote control base and the ground connection.

Check if the RED - BLACK cable between the fuse box under the seat and the fuse box in the glove-box compartment is not interrupted.

Check if the GREY cable between the fuse box in the glove-box compartment and the electric fan remote control base is not interrupted.

Check if the RED cable between the electric fan remote control base and the electric fan motor is not interrupted.

Check that the electric fan motor is earthed.

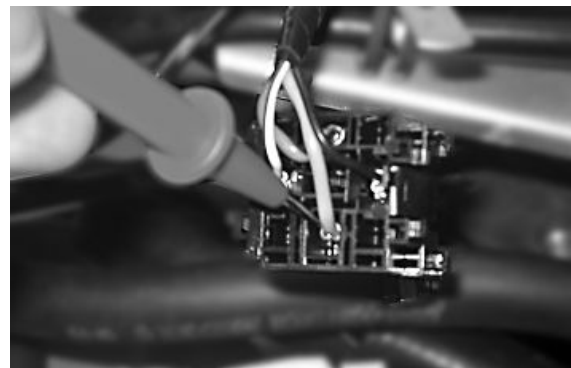

INDEX OF TOPICS

SUSPENSIONS

SUSP

This section is devoted to operations that can be carried out on the suspension.

Front

Removing the front wheel

- Remove the 5 fixing screws indicated in the photograph.

Locking torques (N*m)

Wheel fixing screw 20 ÷ 25



Front wheel hub overhaul

- Support the scooter adequately.
- Remove the front wheel.
- Remove the front calliper.
- Remove the cotter pin and remove the cap.

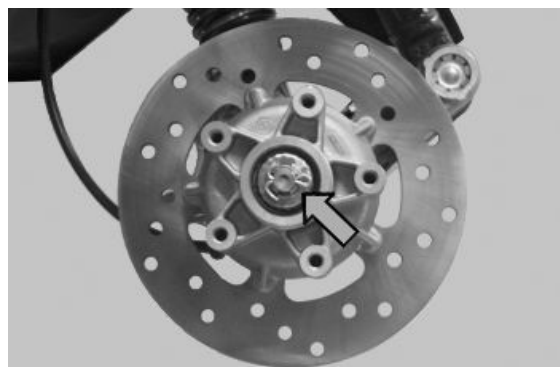

- Unscrew the nut fixing the front wheel hub.



- Remove the wheel hub.

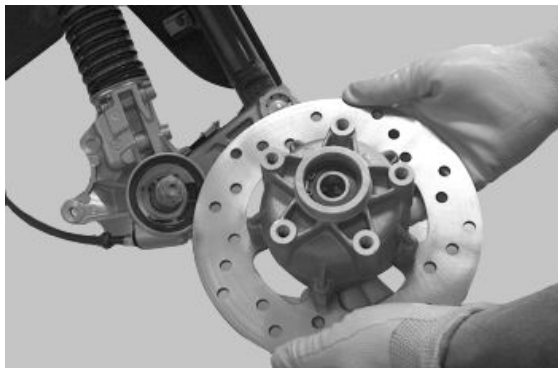

- Remove the ball bearing check seeger ring indicated in the photograph



Extract the ball bearing using the specific tool

Specific tooling

001467Y014 Pliers to extract \varnothing 15-mm bearings

001467Y017 Bell for bearings, OD 39 mm



- Remove the oil seal on the roller bearing side using a screwdriver.



- Remove the roller bearing using the specific tool

Specific tooling

020376Y Adaptor handle

020456Y Ø 24 mm adaptor

020363Y 20 mm guide



- Heat the roller bearing seat with a heat gun
- Use the specific tool to introduce and push the bearing until it stops, with the shielded side facing out
- Refit the ball bearing check seeger ring

Specific tooling

020151Y Air heater

020376Y Adaptor handle

020359Y 42x47-mm adaptor

020412Y 15 mm guide



- Use the specific tool to fit and push the roller casing until it stops
- Refit the oil seal on the roller bearing side
- Lubricate the area between the roller bearing and the ball bearing

Specific tooling

020038Y Punch

Recommended products

AGIP GREASE MU3 Grease for odometer transmission gear case

Soap-based lithium grease with NLGI 3; ISO-L-XBCHA3, DIN K3K-20



Refitting the front wheel

- To refit, carry out the removal operations but in reverse order and comply with the specified locking torque.

Locking torques (N*m)

Wheel fixing screw 20 ÷ 25 Wheel axle nut 74 ÷ 88

Steering column

Removal

- Remove the front wheel
- Remove the brake calliper
- Loosen the screw fixing the odometer cable plate and take out the cable.

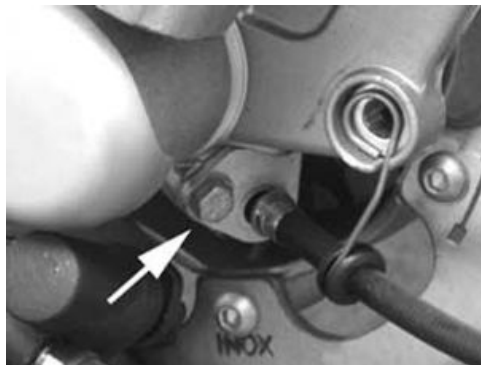

- Remove the suspension arm housing by unscrewing the three screws indicated in the photograph.



- Remove the retainer fixing the odometer cable to the mudguard indicated in the photograph

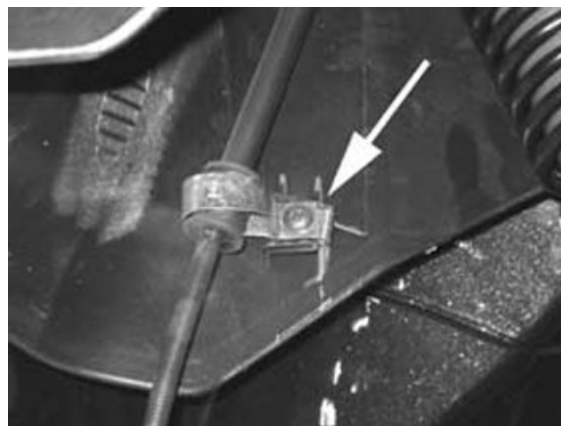

- Remove the retainer fixing the brake piping to the front shock absorber upper plate



- Remove the retainer fixing the brake piping to the suspension arm

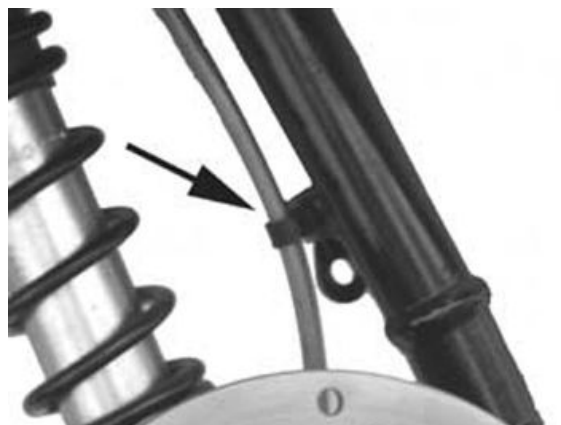

- Pre-loosen the 3 nuts fixing the mudguard to the suspension



- Remove the rear handlebar cover.
- Remove the screw fixing the handlebar to the steering tube
- Tilt the handlebar towards the shield back plate being careful not to scratch the plastic parts



- Remove the steering tube ring nut cover

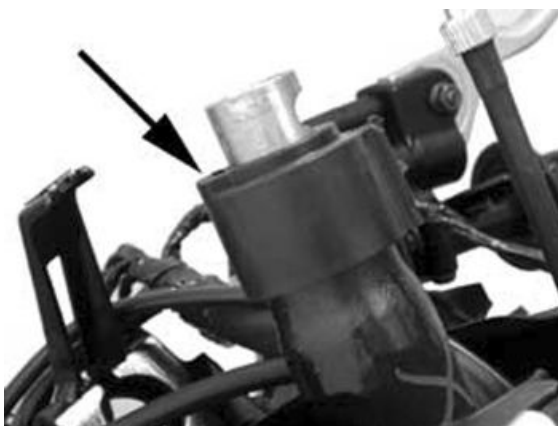

- Use a specific tool to remove the counter-ring nut, the spacer washer and the ring nut of the upper disk of the fifth wheel fitting
- Slide off the steering tube and remove permanently the mudguard from the suspension

Specific tooling

020055Y Wrench for steering tube ring nut



Overhaul

Carry out this operation only if strictly necessary and in any case remove and replace the old part with a new one.

- Remove the steering tube
- Use a special tool remove the upper disk of the fifth wheel fitting seat on the headstock by operating from the lower part of the headstock as indicated in the photograph. Afterwards remove the lower disk of the fifth wheel operating from the upper part

Specific tooling

020004Y Punch for removing fifth wheels from headstock

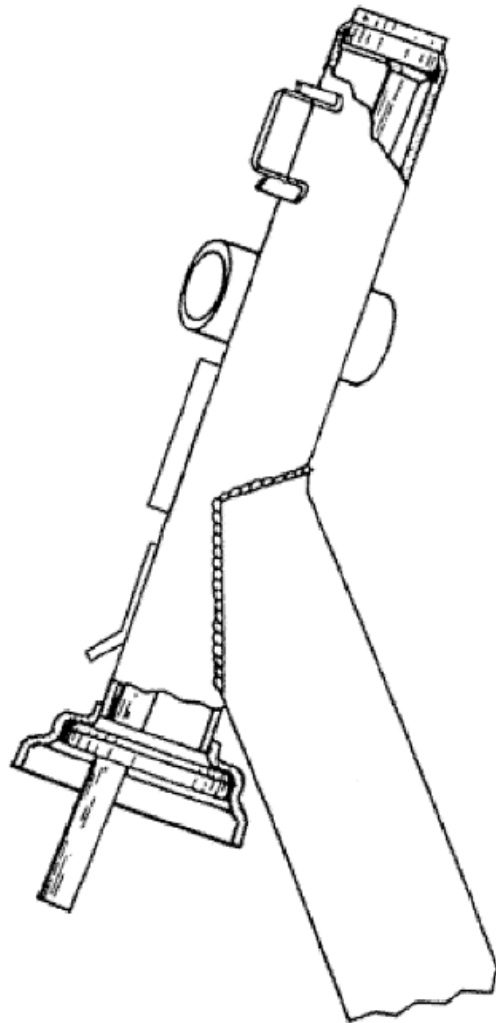

- Remove the fifth wheel fitting and the dust guard on the steering tube as shown in figure, using the specific tool. Proceed giving a few taps with the mallet.

Specific tooling

020004Y Punch for removing fifth wheels from headstock



- Refit the fifth wheel fitting and the dust guard on the steering tube until they stop, using the specific tool.

Specific tooling

006029Y Punch for fitting fifth wheel seat on steering tube



- Use the specific tool to fit the fifth wheel fitting on the headstock as indicated in the figure

Specific tooling

001330Y Tool for fitting steering seats

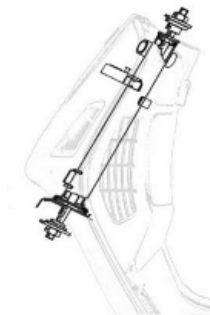

- Remove the steering tube
- Remove the attachment bracket
- Use the specific tool with the part 1 and operate the handgrip until removing temporarily the pin and the Nadella opposite the tool thrusting direction.
- To extract the second Nadella, use the tool with the part 2, instead of part 1, on opposite side to the one indicated in the figure.

Specific tooling

020021Y Front suspension service tool

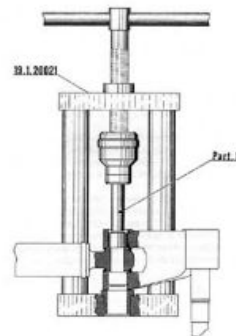

- Fit both dust guard rings «C» on the swinging hub as shown in the detail drawing «A».
- Connect the swinging hub to the steering tube with the guiding pin, part 5.
- Use the specific tool fitted with part 3 on the stem and part 4 on the tool base.
- Lubricate the pin with recommended grease and insert it temporarily on the swinging hub, move the tool handgrip until part 3 is fully inserted on the steering tube.

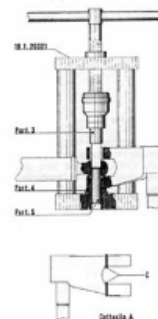

- Once the pin has been fitted, insert the two spacers part 17 slightly hitting with a mallet (see next figure).

CAUTION

USE NEW ROLLER CASINGS, PIN, SEALING RINGS AND DUST GUARDS FOR REFITTING.

Specific tooling

020021Y Front suspension service tool

Recommended products

AGIP GREASE PV2 Grease for the steering bearings, pin seats and swinging arm

Soap-based lithium and zinc oxide grease containing NLGI 2; ISO-L-XBCIB2 of the swinging arm

To fit sealing rings, roller casings and wedging washers proceed as follows

- Lubricate the sealing rings with mineral oil and half-fill the roller casings with recommended grease.
- Insert the sealing ring on the pin and the roller bushing with wedging washers at the same time.
- Remove the specific tool and then the part 5 (guide) partially ejected in the previous assembly stage; part 4 must be always fitted.
- Replace part 3 with part 16 on the stem.
- Push, from the handgrip, the wedging washer - roller casing - sealing ring unit, placing part 16 until it stops on the swinging hub
- Repeat the operation described above using the tool fitted with part 16 and part 22* instead of part 4 on the stem, on the side opposite the one shown in the figure to refit the second wedging washer - roller casing - sealing ring unit.

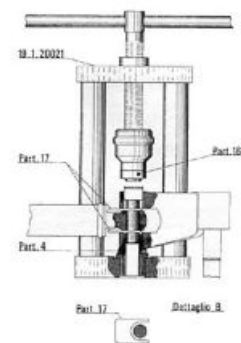

To position roller casings on the pin (pin end in contact with the internal bottom of the roller casings) proceed as follows:

- Use the tool with part 20 and 21 fitted to the stem as indicated in the figure.
- Push the two roller casings with the handgrip until their bottoms make contact with the pin end.
- Use the specific tool fitted with parts 3 and 4 as indicated for fitting the spin and push with the handgrip until the washer is wedged in the swinging hub.
- Remove the spacers, part 17; fill with recommended grease the area between the steering tube and the swinging hub, and place the dust guard rings in that place.

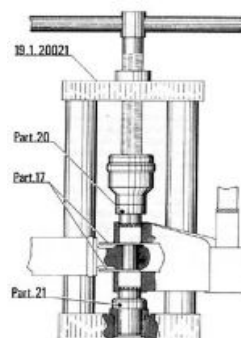

Recommended products

AGIP GREASE PV2 Grease for the steering bearings, pin seats and swinging arm

Soap-based lithium and zinc oxide grease containing NLGI 2; ISO-L-XBCIB2 of the swinging arm

Refitting

To refit, carry out the removal operations but in reverse order; grease the fifth wheel fittings and tighten at the specified locking torques

Locking torques (N*m)

Handlebar to steering tube 45 ÷ 50 Upper steering ring nut 35 ÷ 40 Steering lower ring nut 12 ÷ 14

Front shock absorber

Removal

- Support the scooter adequately.
- Remove the wheel hub.
- Loosen the shock absorber lower clamps and remove the brake calliper shock absorber support.

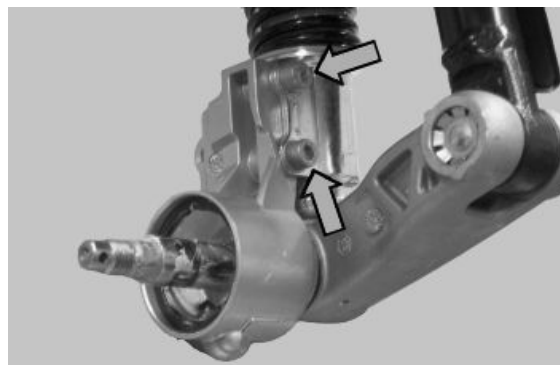

- Loosen the screws fixing the front brake pipe retainer clamp and the odometer cable in order to reach the upper clamps.

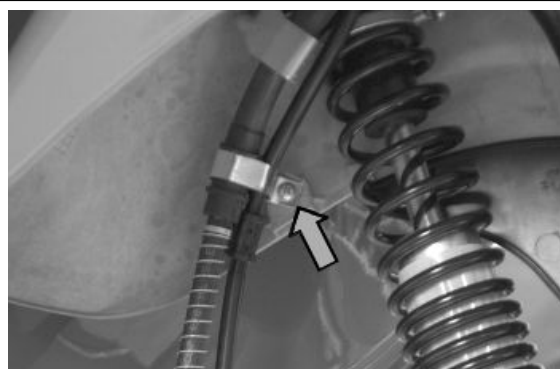

- Unscrew the upper fixing nuts.

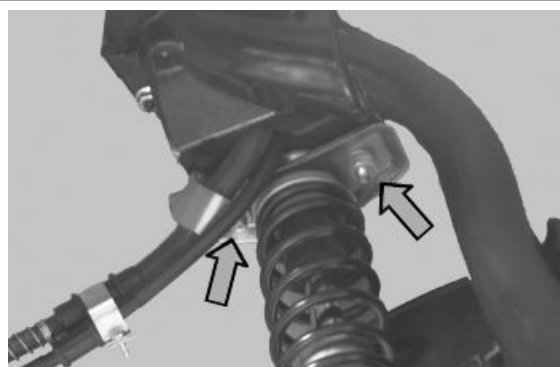

- Remove the front shock absorber.



Refitting

To refit, carry out the removal operations in reverse order, observing the prescribed tightening torques.

Locking torques (N*m)

shock absorber lower clamp 20 - 27 shock absorber upper clamp 20 ÷ 30

Shock-absorber - calliper bracket

- Remove the front wheel hub with the brake disc
- Remove the front shock absorber lower clamps



- Remove the bracket locking seeger ring
- Unscrew the bracket



- Before refitting the bracket in the wheel axle, place the O-ring as shown in the photograph so that it is correctly placed after fitting the bracket.
- Refit the washer and the Seeger ring.
- Refit the lower screws fixing the shock absorber to the bracket and tighten at the prescribed torque



Locking torques (N*m)

Lower shock absorber clamp 20 ÷ 27

Overhaul

- The bracket for the shock absorber -calliper attachment has two roller bearings separated one from the other as shown in the photograph



- Remove the two roller bearings from the bracket with the specific tool operating on the shock absorber attachment side as shown in the photograph



Specific tooling

020376Y Adaptor handle

020441Y 26 x 28 mm adaptor

020365Y 22 mm guide

- Remove the oil seal on the wheel hub side with the screwdriver as shown in the photograph



- Suitably hold the brake calliper - shock absorber attachment bracket

- Fit a new oil seal and move it until it stops using the specific tool

Specific tooling

020376Y Adaptor handle

020360Y Adaptor 52 x 55 mm



- Assemble a new roller bearing on the shock absorber side and move it until it stops using the specific tool

Specific tooling

020036Y Punch



- Suitably hold the brake calliper - shock absorber attachment bracket

- Assemble a new roller bearing on the wheel hub side and move it until it stops using the specific tool

Specific tooling

020037Y Punch



Refitting

- Refit the parts in reverse order of the removal operation.

CAUTION

BEFORE CARRYING OUT REFITTING OPERATIONS IN THE AREAS MARKED WITH AN ASTERISK, LUBRICATE THEM WITH THE RECOMMENDED PRODUCT

Specific tooling

020036Y Punch

020037Y Punch

Recommended products

AGIP GREASE PV2 Grease for the steering bearings, pin seats and swinging arm

Soap-based lithium and zinc oxide grease containing NLGI 2; ISO-L-XBCIB2 of the swinging arm

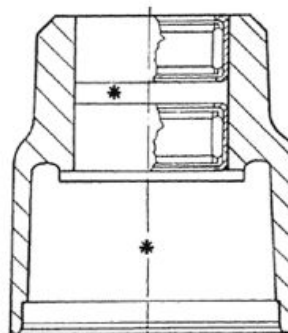

Rear

Removing the rear wheel

- Remove the bracket supporting the rear shock absorber and the muffler;
- Remove the rear wheel by unscrewing the 5 screws indicated in the photograph



Refitting the rear wheel

To refit, carry out the removal operations but in reverse order, observing the prescribed torques.

Locking torques (N*m)

Wheel fixing screws: 20 - 25

Swing-arm

Removal

- Place the scooter on its centre stand;
- Remove the engine housing
- Remove the swinging arm/engine fitting shown in the photo
- Move the engine back

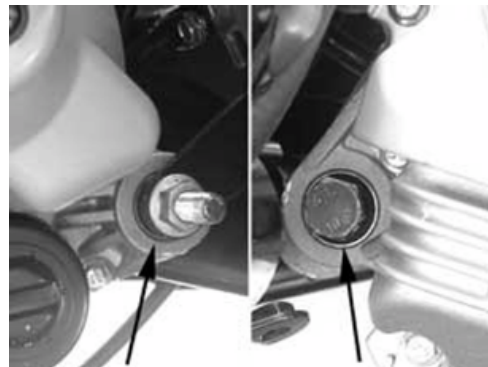

- remove the spring anchoring the swinging arm to the frame as shown in the photo



- Remove the two screws fixing the buffer support bracket to the frame

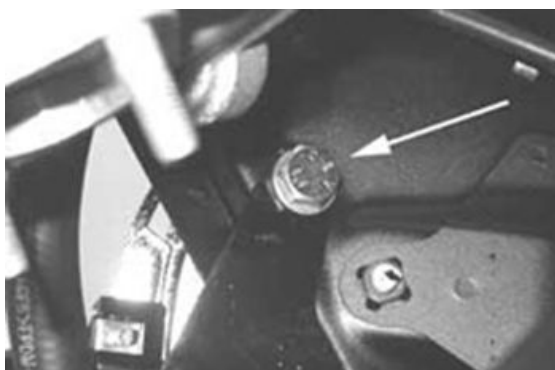

- Remove the left and right caps located under the footrest to reach the pin fixing the swinging arm to the body.
- Remove the pin. Then remove the swinging arm.



- Check the entire swinging arm assembly.
- Check all the centring bushing components and silent block rubber buffers.
- Replace the work components that cause excessive clearance on the rear suspension.



Overhaul

- Check there is no sticking in the movement of the connection of the swinging arm on the engine side to the swinging arm on the frame side.
- Check the axial clearance between the two swinging arms using a feeler thickness gauge



Characteristic

Standard clearance

0.40 ÷ 0.60 mm

Allowable limit after use:

1.5 mm

- To check the clearance on the frame-side arm, mount the retainer using the pin fixing the swinging arm to the frame and two adaptor rings of the appropriate tool 020229Y. Alternatively use two washers with inner diameter for 12-mm pins, min. outer diameter: 30 mm: min. thickness: 4 mm.



- Check there is no sticking in the rotation.
- Check the axial clearance of the swinging arm on the frame side

Characteristic

Standard clearance

0.40 ÷ 0.60 mm

Allowable limit after use:

1.5 mm



- Separate the swinging arm on the engine side from the vehicle side arm.
- Remove the plastic bushings and the internal spacer shown in the photo.

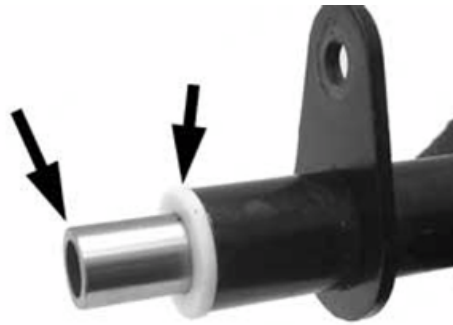

- Using a suitable pin remove the roller casings as shown in the photographs



- Using an appropriate tool plant new roller casings, being careful to position the bearings with the O-rings facing outwards

Specific tooling

020244Y 15 mm diameter punch

020115Y Ø 18 punch

Characteristic

Length of the swinging arm tube on the engine side:

L 175.3 + 0.3 0

Length of the internal swinging arm spacer on the engine side:

L 183 + 0.3 0

Engine side swinging arm plastic bushing shim:

3.5 ± 0.05 mm

Frame-side swinging arm plastic bushing shim:

3.5 ± 0.05 mm

Length of the internal swinging arm spacer on the frame side:

290 ± 0.1 mm



Length of the swinging arm tube on the frame side:

283 ± 0.1 mm

- Lubricate roller casings and the plastic bushings with grease
- Insert the spacers
- Assemble the two arms with the relative bolt in the position shown in the photograph
- Adjust the bolt as shown in the photograph
- Position the frame side swinging arm with the most protruding part pointing towards the silent block side as shown in the photograph



Recommended products

AGIP GREASE PV2 Grease for the steering bearings, pin seats and swinging arm

Soap-based lithium and zinc oxide grease containing NLGI 2; ISO-L-XBCIB2 of the swinging arm

- Make sure the silent bloc is not broken. If there is, replace it.
- Remove the seeger ring shown in the photograph

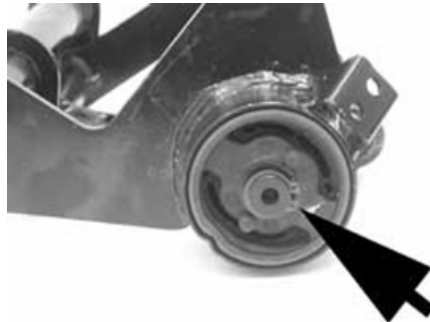

- Remove the full silent bloc bracket
- Undo the silent bloc ring shown in the photograph



- Hold the full silent bloc bracket in the clamp
- Using the appropriate tool, remove the silent bloc from the bracket from the side corresponding to the inside of the vehicle. This is to guarantee the tool is centred properly on the support



- Install a new silent bloc, making sure it aligns properly with the reference tooth.
- Fit the silent blocs, making sure the chamfered part of the silent bloc matches the chamfered part of the bracket

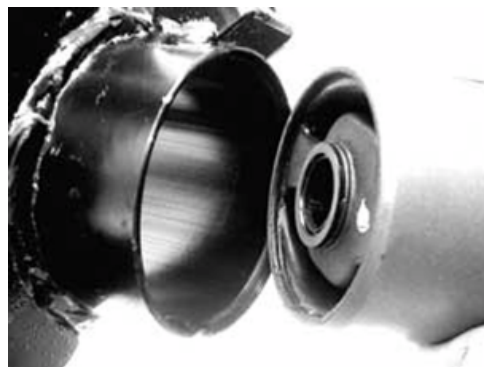

- Using the appropriate tool, fit the silent bloc as shown in the photo



Refitting

- To refit, perform the removal operations in reverse.
- Grease the bearings and the rolling parts with the recommended grease.

-Complete the fitting by tightening the nuts on the relative bolts to the proper tightening torque.

Locking torques (N*m)

Engine- and vehicle-side swinging arm junction bolt 40 ÷ 45 Swinging arm pin - Engine 64 - 72
Body shell - Swinging arm pin 76 ÷ 83 Screw fixing the silent-block support plate to the body 42 ÷ 52

Shock absorbers

Removal

Proceed as follows:

- place the scooter on its centre stand;
- remove the luggage rack
- lift the engine a little with a jack so as to free the two shock absorbers;
- remove the muffler assembly;
- undo the shock absorber spring assembly clamping screw from the support fixed to the engine on the one side and from that fixed to the muffler on the other;
- unscrew the two upper nuts (one on each side) fixing the shock absorber spring assembly to the frame and remove the shock absorbers.

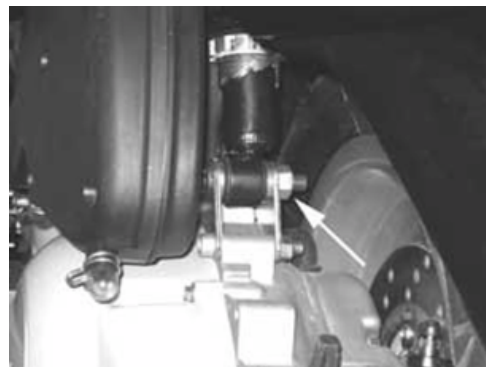
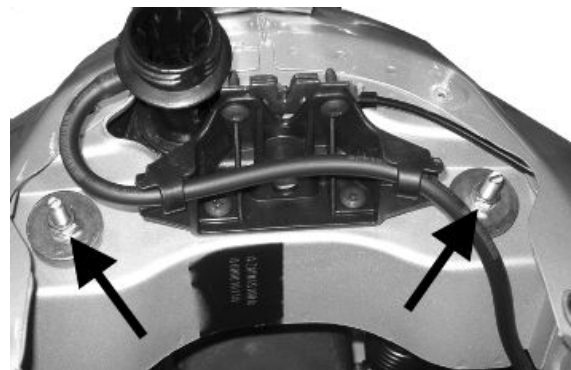

Refitting

To refit, carry out the above removal operations in reverse order, observing the prescribed torques.

Locking torques (N*m)

Shock absorber lower fitting 40 ÷ 45 Upper shock absorber fixing screws 20 ÷ 25 Nm

Exhaust bracket

Removal

Remove the full muffler unit.

- Remove the two fixing screws of the bracket to the engine crankcase
- Remove the split pin, the cover and the fixing nut of the rear wheel axle and its spacer
- Remove the shock absorber lower clamp

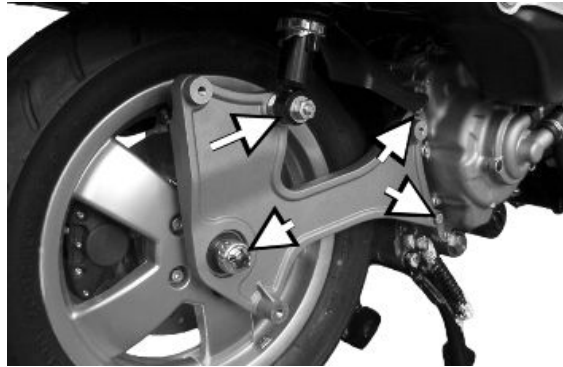

Refitting

- The refitting procedure is in the reverse order of the removal operation being careful to respect the torques indicated and the spacer assembly layout as shown in the photo.

Locking torques (N*m)

**Bracket fixing screws to the engine crankcase: 20 ÷ 25 Shock absorber lower fitting 40 ÷ 45
Wheel axle clamping 104 ÷ 126**

Centre-stand

REMOVAL

- Use a jack to support the vehicle properly.
- Remove the two return springs from the centre stand.
- Undo the nut shown in the figure.
- Remove the bolt from the right side.
- Remove the centre stand.



FITTING

- On refitting tighten the nut to the specified torque.

Locking torques (N*m)

Centre stand bolt 32 ÷ 40

Side stand

REMOVAL

- Uncouple the centre stand return spring;
- Remove the screw shown in the photograph

FITTING

To refit, carry out the removal operations in reverse order and comply with the specified torque.

Locking torques (N*m)

Side stand fixing bolt 35 ÷ 40



INDEX OF TOPICS

BRAKING SYSTEM

BRAK SYS

This section è is devoted to the description of the braking system components.

Rear brake calliper

Removal

- Remove the rear wheel.
- Remove the pad retention pin snap ring.
- Using a pin partially remove the brake pad retention pin.
- Remove the screws fixing the brake calliper to the crankcase then remove the brake calliper complete with pipe.
- Complete the extraction of the pad retention pin, the spring and the pads.

N.B.

SHOULD THE BRAKE CALLIPER BE REPLACED OR SERVICED, BEFORE REMOVING THE FITTINGS FIXING THE CALLIPER TO THE SUPPORT BRACKET, LOOSEN THE OIL HOSE FITTING AFTER HAVING EMPTIED THE SYSTEM OF THE CIRCUIT BEING EXAMINED.

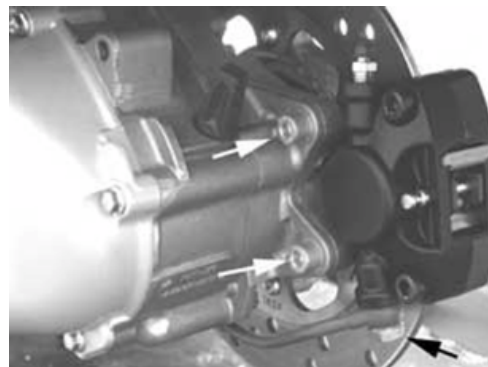

Overhaul

- Remove the rear brake calliper.
- Suitably hold the brake calliper in a clamp
- Remove the two calliper coupling screws as shown in the photo
- Remove the two pistons from the calliper body with the aid of short blasts of compressed air through the brake fluid holes
- Remove the dust ring and the O-ring of each half calliper.
- Remove the O-rings in the half calliper.

N.B.

WHEN REMOVING THE O-RINGS, BE CAREFUL NOT TO SCRATCH THE HALF CALLIPER SEATS





- Check that the pistons and their seats show no scratches.
- Wash and blow all the components carefully
- Fit the O-rings and new dust guards
- Refit the pistons in their seats being careful to lubricate with brake fluid
- Re-couple the half callipers and lock the two screws at the specified torque



Locking torques (N*m)

Calliper coupling screw 30 ÷ 33 Nm



Refitting

- Follow the removal steps but in reverse order and tighten to the prescribed torque.

Locking torques (N*m)

Calliper fixing screw 24 ÷ 27

If the calliper is replaced:

CAUTION

ONCE REFITTING IS FINISHED, BLEED THE SYSTEM.

CAUTION

ALWAYS USE NEW COPPER WASHERS.

Locking torques (N*m)

Screw fixing the oil connection to the calliper 19 ÷ 24

Front brake calliper

Removal

- Remove the front wheel
- Pre-loosen the two fixing pins of the brake pads
- Remove the two front brake calliper devices fastening them to the support as shown in the photograph.

N.B.

WHEN A PROCEDURE IS PLANNED INCLUDING THE SERVICE OR REPLACEMENT OF THE CALLIPER, FIRST LOOSEN THE FITTING CONNECTING THE PIPE TO THE BRAKE CALLIPER

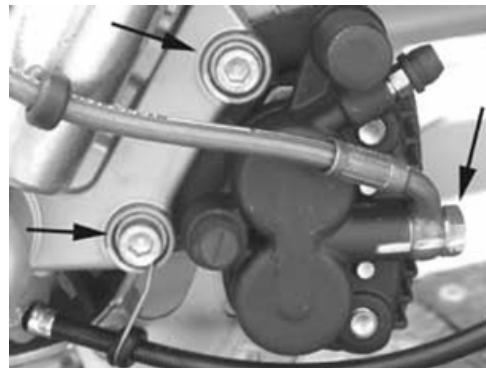

Overhaul

Proceed as follows:

- 1) remove the two male hexagonal screws (1) and take out the two pads (10);
- 2) remove the two male hexagonal screws (2) and remove the reaction plate (3);
- 3) take out the fixed plate (4) from the guide;
- 4) remove the internal elements from the floating body (5) with the help of short blows of compressed air through the brake fluid pipe in order to facilitate the expulsion of pistons (6).
- 5) Check:
 - that the plates and the body are whole and in good condition;

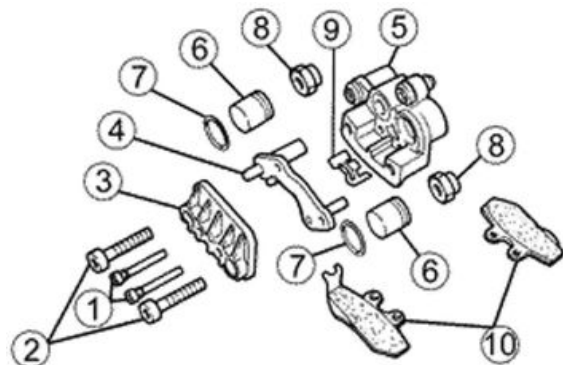

- that the cylinder and the floating body of the calliper do not show signs of scratches or erosion, otherwise replace the entire calliper;
- that the guides of the fixed plate are not scratched or eroded, otherwise replace the entire plate;
- that the brake pad check spring works properly.

CAUTION

ALL THE INTERNAL COMPONENTS MUST BE REPLACED EVERY TIME THE CALLIPER IS SERVICED.

The brake pad check spring

1. pad fixing screws
2. reaction plate fixing screws
3. reaction plate
4. fixed plate
5. floating body
6. piston
7. piston sealing rings
8. guide protection rubbers
9. brake pad check spring
10. pads

Refitting

Insert the following on the front brake body:

- The sealing rings and the pistons (1).
- Refit the plate (2).
- Arrange the pad holding clamp (3).
- Refit the pads and bleed air.
- Place the calliper on the disk and lock it to the support by tightening the bolts at the prescribed torque.
- Lock the pipe joint to the calliper at the prescribed torque.

CAUTION

ALWAYS USE NEW COPPER WASHERS.

Locking torques (N*m)

Screws fixing the front calliper to the support: 24 ÷ 27 Screw fixing the oil connection to the calliper 19 ÷ 24

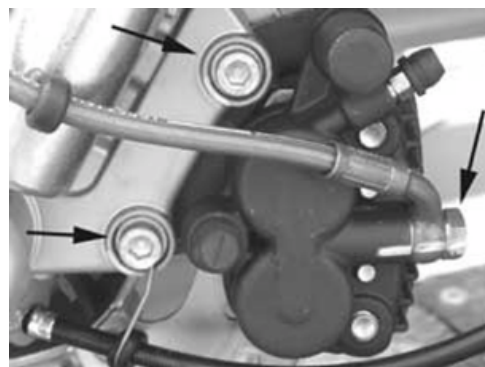
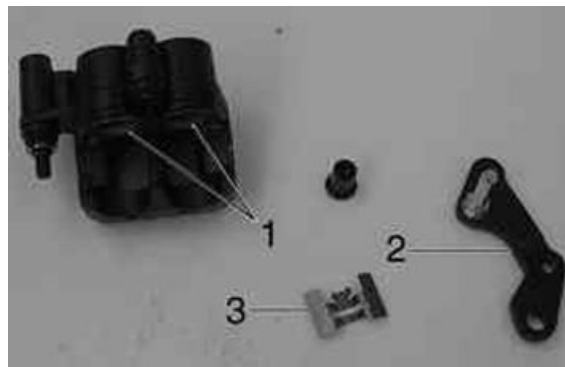

Rear brake disc

Removal

- Remove the rear brake calliper.
- Remove the brake disc and the hub from the wheel axle
- To remove the brake disc from the hub, hold the unit firmly with a vice and operate on the 5 fixing screws indicated in the photograph

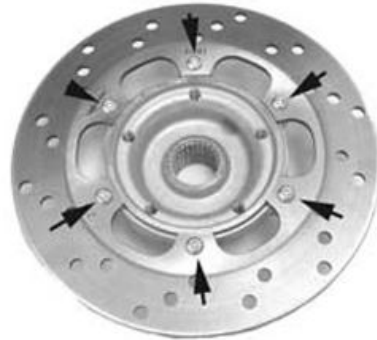

Refitting

- To reassemble the brake disc on the hub, carry out the removal operations in the reverse order arranging the brake disc on the hub on the side opposite the wheel keying
- Follow the direction of rotation shown by the arrow and tighten to the prescribed torque.
- Fit the hub unit
- disc in the wheel axle

Locking torques (N*m)

Disk to the hub 11 ÷ 13

Disc Inspection

- Remove the rear brake calliper.
- Check the disc thickness with a micrometer

Characteristic

Standard thickness:

3.5 mm



- Repeat the measurement at no fewer than six points on the disc.
- Check the regular nature of the rotation of the brake disc assembly using the appropriate tool fixed onto the brake calliper as shown in the photo.
- In order to be able to anchor the appropriate tool properly use a metal plate with M8 threaded hole and fix it to one of the two rear brake calliper attachment points.
- Suitably fix the flange to the wheel axle with the original nut and spacer and a Æ 17 mm bearing.

N.B.

SO AS NOT TO GET A DISTORTED READING, CAUSE THE DRIVEN PULLEY SHAFT TO TURN IN ORDER TO ROTATE THE DISC.

Specific tooling

020335Y Magnetic support for dial gauge

Characteristic

Max. deviation allowed:

0.1 mm

- If you detect incorrect values, replace the disc. If the anomaly persists, replace the hub.

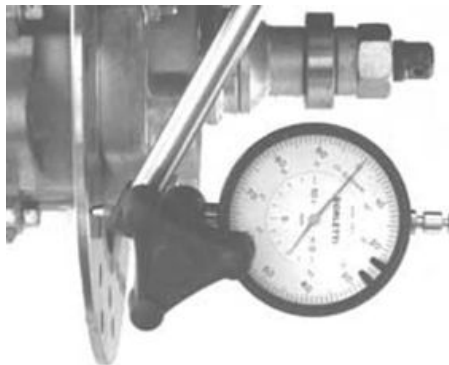

Front brake disc

Removal

- Remove the front wheel
- Remove the front brake calliper
- Remove the hub and the disc operating on the wheel axle nut
- Hold the hub and the disc firmly and remove the brake disc undoing the six screws indicated in the photograph

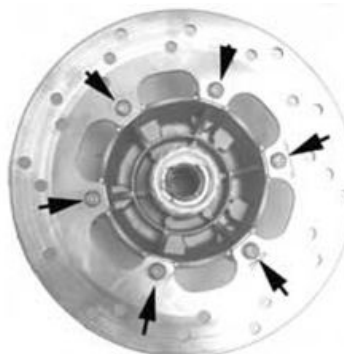

Refitting

- Carry out the operations in the reverse order from the removal being careful to respect the direction of disc rotation shown by the arrow printed on it
- Tighten the six screws to the specified torque.

Locking torques (N*m)

Brake disc screws 8 ÷ 10



Disc Inspection

- Remove the front wheel
- Use a micrometer to check the disc thickness as shown in the photograph
- Repeat the measurement in at least 6 points on the disk
- Remove the front brake calliper
- In order to secure the appropriate tool adequately use a metal plate with M8 threaded hole and fix it to one of the two front brake calliper attachment points
- Place the dial gauge on the disk outer edge
- Make the wheel hub turn and check the disk deviation



Specific tooling

020335Y Magnetic support for dial gauge

Characteristic

Standard thickness:

3.5 mm

Max. deviation allowed:

0.1 mm

Front brake pads

Removal

- Remove the front wheel
- Pre-loosen the two fixing pins of the brake pads
- Remove the brake calliper
- Remove permanently the two pad fixing screws
- Check that there are no flaws or warping. If there is, replace it.
- Check the thickness of the friction material is more than 1.5 mm. If it is not, replace it
- The replacement must be made with greater residual thickness if the pad has not worn evenly. A 0.5 mm thickness difference in the residual friction material is permitted

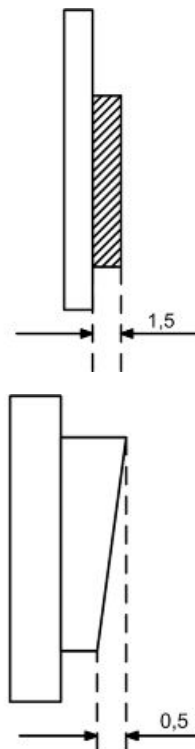
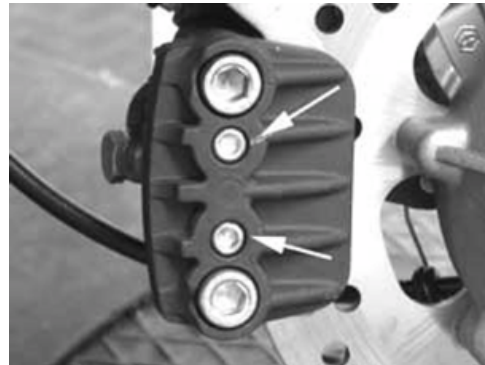

Refitting

To fit, proceed as follows:

- Insert the two pads in the callipers.

- Screw the two pad lock pins to the correct torque, and apply the recommended product.
- Fit the calliper on its support, tightening the two screws to the prescribed torque.

N.B.

IF IT IS NOT POSSIBLE TO CORRECTLY POSITION THE CALLIPER ON THE DISC DURING FITTING, GENTLY EXPAND THE PADS.

Recommended products**Loctite 243 Medium strength threadlock**

Loctite 243 medium-strength threadlock

Locking torques (N*m)

Screw tightening calliper to the support 24 ÷ 27 Pad fastening pin 19.6 ÷ 24.5

Rear brake pads

Removal

- Remove the rear brake calliper.
- Remove the snap ring, slide off the pad retention pin and the clip.



- Remove the brake pads and check there are no faults or warping. Otherwise, replace them.
- Check the thickness of the friction material is more than 1.5 mm. If it is not, replace it
- The replacement must be made with greater residual thickness if the pad has not worn evenly. A 0.5 mm thickness difference in the residual friction material is permitted

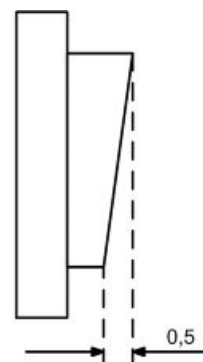
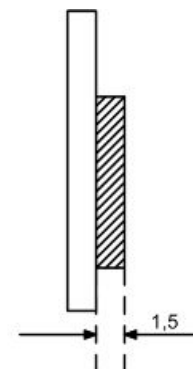

Refitting

- Insert the brake pads
- Insert the fixing pin being careful to position the clip with the ends towards the bleed screw as in the photo.



- Insert the lock on the bolt and then the protection cover



N.B.

FAILURE TO RESPECT THE PAD POSITIONING REQUIREMENTS WITH RESPECT TO THE DIRECTION OF ROTATION COULD COMPROMISE PROPER BRAKE FUNCTIONING AND NOISELESSNESS.

Fill

Rear - combined

- Remove the rubber hood from the bleed screw.
- Insert a rubber pipe in the bleed screw to permit the brake fluid to be recovered.
- With the left-hand brake lever, load the system and bring it up to the required pressure.
- Keeping the left-hand brake lever pulled, loosen the bleed screw to permit the air in the system to escape. Then tighten the bleed screw
- Repeat the operation until only brake fluid comes out of the rubber pipe.
- Remove the fluid recovery pipe and refit the rubber cap over the bleed screw.
- Top up the brake fluid to the right level in the reservoir.



If necessary, bleeding can be done using a special vacuum pump

N.B.

DURING THE BLEEDING OPERATIONS, MAKE SURE THE BRAKE FLUID DOES NOT COME INTO CONTACT WITH THE BODYWORK SO AS NOT TO DAMAGE IT. FURTHERMORE, DURING THE BLEEDING OPERATIONS REGARDING THE BRAKE CALLIPERS, MAKE SURE THE BRAKE FLUID DOES NOT COME INTO CONTACT WITH THE DISC BRAKES AND WITH THE BRAKE PADS. FAILURE TO COMPLY WITH THIS NORM WILL ENDANGER THE PROPER WORKING AND EFFICIENCY OF THE BRAKING SYSTEM

Specific tooling

020329Y MityVac vacuum-operated pump

Locking torques (N*m)

System bleed calliper fitting: 12 ÷ 16 Nm

Brake fluid level check

- Position the vehicle on a flat surface and on the centre stand
- Remove the brake pump cover as indicated in the photo



- Use the appropriate spyglass on the pump to check the level of the brake fluid, as shown in the photograph



- If the level is below the minimum, fill up by acting on the two screws shown in the figure.
- Remove the gasket and fill with recommended brake fluid until the spyglass is completely covered.



CAUTION



AVOID CONTACT OF THE BRAKE FLUID WITH YOUR EYES, SKIN, AND CLOTHING. IN CASE OF ACCIDENTAL CONTACT, WASH WITH WATER.

CAUTION

THE BRAKING CIRCUIT FLUID IS HIGHLY CORROSIVE. THEREFORE, WHEN TOPPING IT UP, AVOID LETTING IT COME INTO CONTACT WITH THE PAINTED PARTS OF THE VEHICLE. THE BRAKING CIRCUIT FLUID IS HYGROSCOPIC, THAT IS, IT ABSORBS HUMIDITY FROM THE SURROUNDING AIR. IF MOISTURE CONTAINED IN THE BRAKE FLUID EXCEEDS A CERTAIN VALUE, THIS WILL RESULT IN INEFFICIENT BRAKING.

CAUTION

THE BRAKE FLUID IS HYGROSCOPIC, THAT IS, IT ABSORBS MOISTURE FROM THE SURROUNDING AIR. IF THE LEVEL OF HUMIDITY IN THE BRAKE FLUID EXCEEDS A GIVEN VALUE, BRAKING EFFICIENCY WILL BE REDUCED.

Never use brake liquid in open or partially used containers.

Under standard climatic conditions, replace coolant as indicated in the scheduled maintenance table.

For refitting purposes carry out the removal operations but in reverse order and respect the tightening torques of the tank cover screws.

Locking torques (N*m)

Brake pump reservoir screws $1.5 \div 2$

Front brake pump

Removal

- Remove the rear handlebar cover.
- Remove the two screws fixing the brake pump to the handlebar indicated in the photograph
- Remove the oil pipe joint from the pump
- Remove the connector to the stop light switch

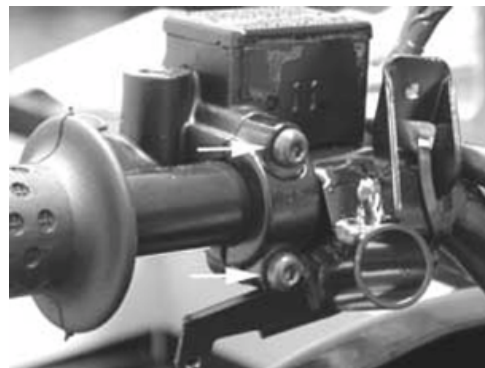



Overhaul

Proceed as follows:

- 1) Remove the brake lever by loosening the retaining screw; open the cover (2) and take out the diaphragm (3);
- 2) remove the cap (4) and take out the internal parts in order;
- 3) Check that:
 - The body of the pump shows no signs of internal damage or corrosion;
 - The plunger shows no sign of damage or abnormal wear;
 - The plunger return spring is in good condition.

CAUTION

ALL THE SEALS AND GASKETS MUST BE REPLACED EVERY TIME THE PUMP IS SERVICED.

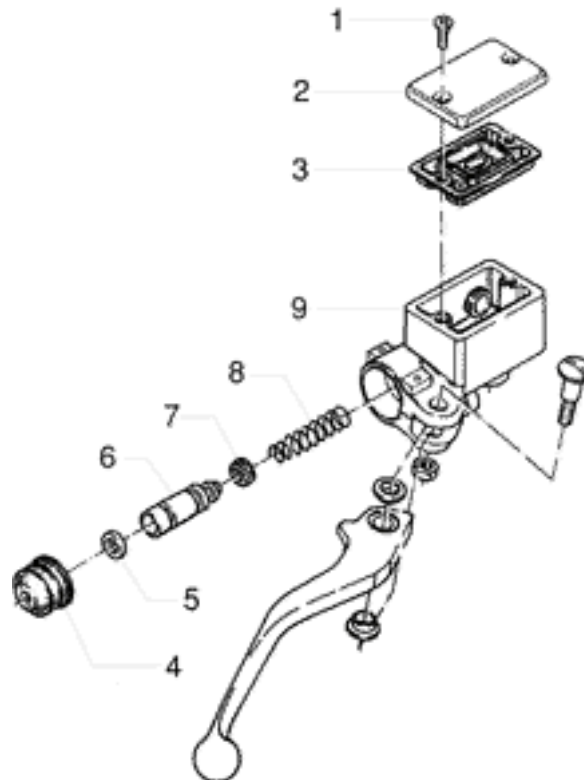

1. Reservoir cap screw
2. Reservoir cap.

3. Diaphragm.
 4. Bellows.
 5. Sealing ring
 6. Piston.
 7. Gasket.
 8. Spring.
 9. Reservoir
-

Refitting

To refit, carry out the removal operations but in reverse order, observing the specified torques.

Locking torques (N*m)

Oil pipe joint to the pump: 20 - 25 Brake pump fixing screws to the handle bar: 7 ÷ 10 Nm

INDEX OF TOPICS

COOLING SYSTEM

COOL SYS

Circuit diagram

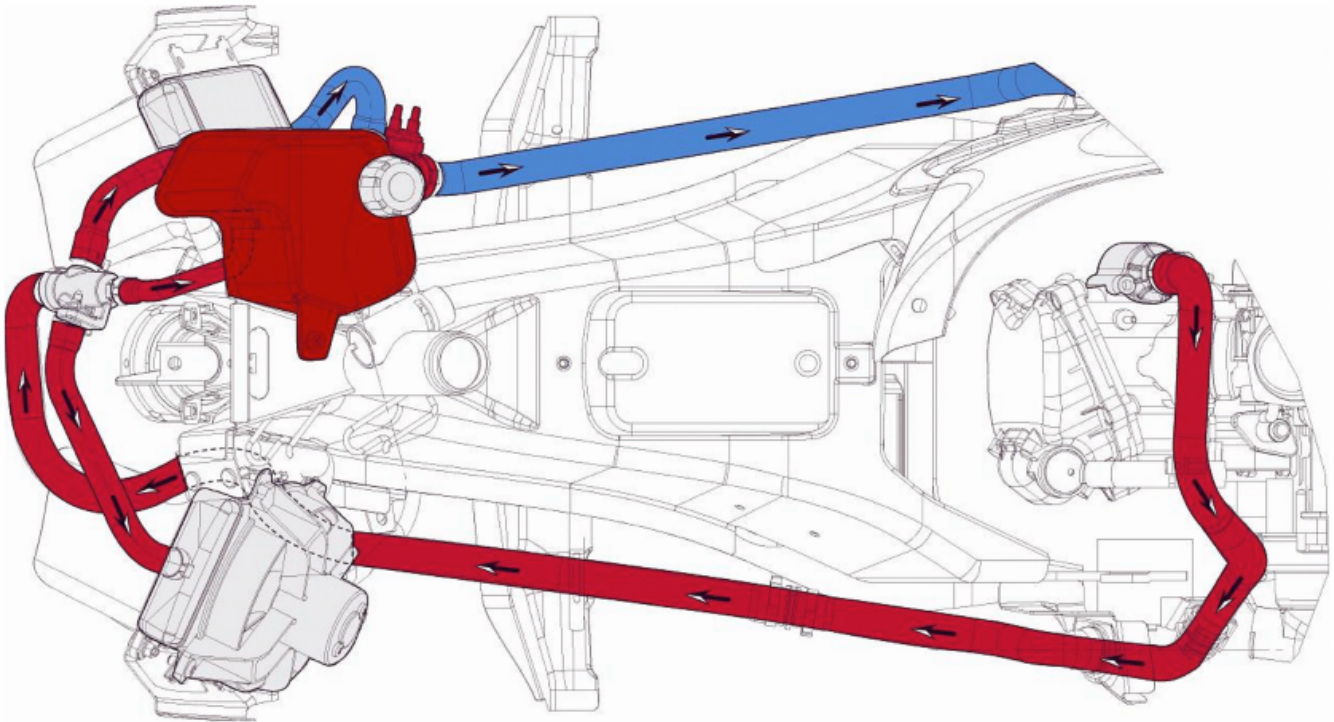

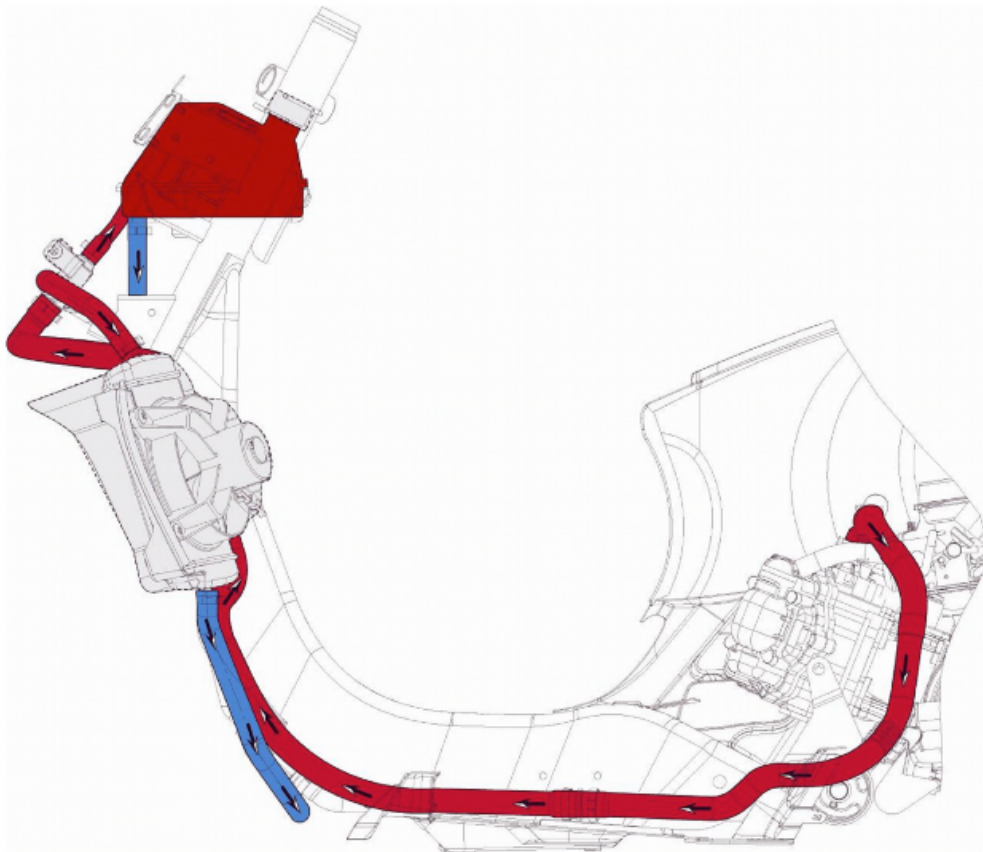

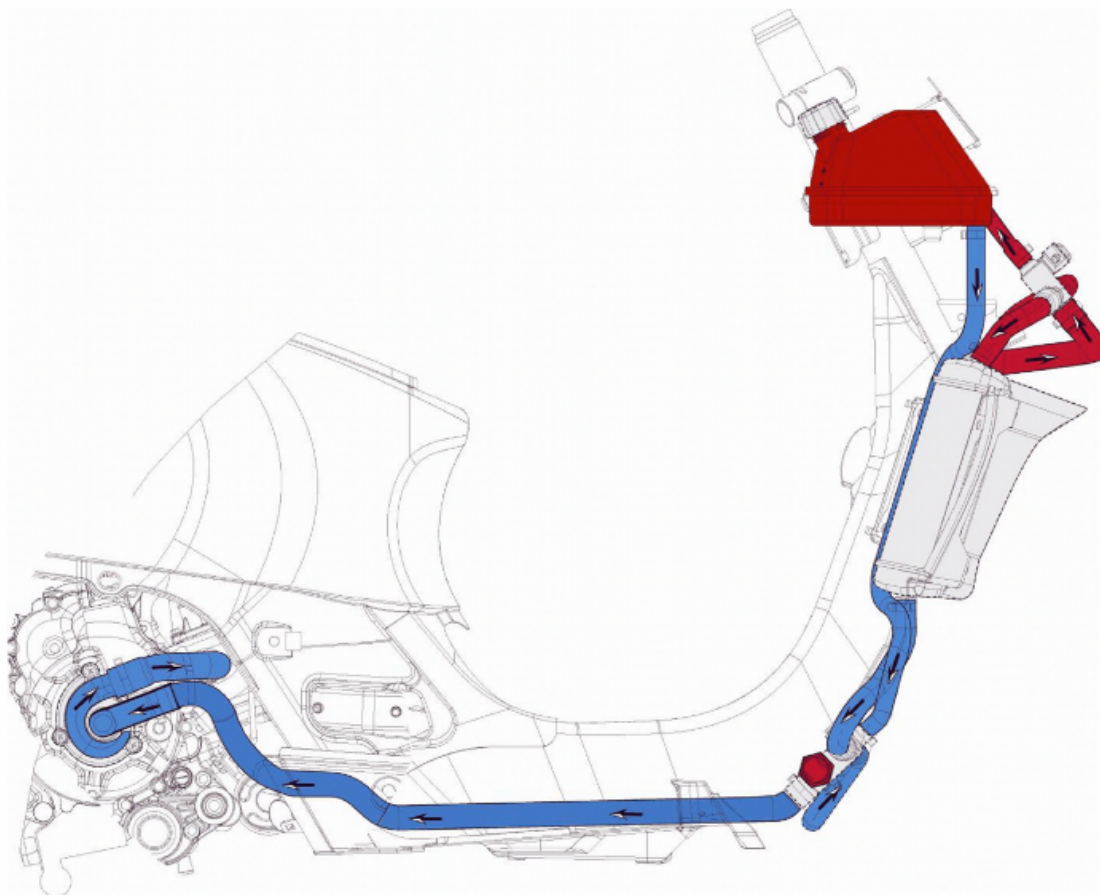

System bleed

- Start up the engine until the operating temperature is reached.
- Remove the rubber hood over the bleed valve
- Obtain a rubber tube that is of the right length to connect the valve to the expansion tank
- Place one end of the pipe on the bleed valve and the other in the expansion tank
- Loosen the screw by **two** turns until the communication hole is revealed with the head as shown in the photo
- Wait until only coolant comes out of the rubber pipe so as to eliminate any air bubbles inside the circuit.
- Tighten the bleed valve respecting the maximum torque.



- Bring the coolant up to the correct level inside the expansion tank

Locking torques (N*m)

Bleed screw 3

Thermostat

Removal

- Remove the helmet compartment.
- Place a + 2.0 l container under the vehicle to collect the coolant.
- Undo the two screws indicated, lift the cover and remove the thermostat.

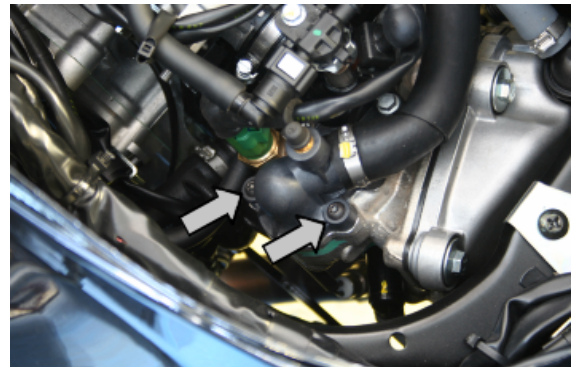

Check

- 1) Visually inspect that the thermostat is not damaged.
 - 2) Fill a metal container with approx. 1 litre of water.
- Immerse the thermostat, and keep it in the centre of the container.
- Immerse the multimeter temperature probe, and keep it close to the thermostat.
- Heat up the container using the thermal gun.



Check the temperature at which the thermostat starts to open:

Heat up until the thermostat is completely open.

3) Replace the thermostat if it is not working properly.

CAUTION

TO EXECUTE THE TEST CORRECTLY, MAKE SURE NEITHER THE THERMOSTAT NOR THE THERMOMETER TOUCHES THE CONTAINER.

Specific tooling

020331Y Digital multimeter

020151Y Air heater

THERMOSTAT

Specification	Desc./Quantity
Type	Wax-type, with deviator
Starts opening	85±2°C

Refitting

- Follow the removal steps but in reverse order; be careful to tighten screws to the prescribed torque.

Locking torques (N*m)

Thermostat cover screws 3 ÷ 4

- Once the cooling circuit is restored, refill using the recommended product and purge the circuit as expressly indicated in the «Cooling System» chapter.

INDEX OF TOPICS

CHASSIS

CHAS

This section è is devoted to the operations that can be carried out on the vehicle's bodywork.

Seat

- Remove the helmet compartment
- Remove the two screws shown in the photograph
- Remove the saddle

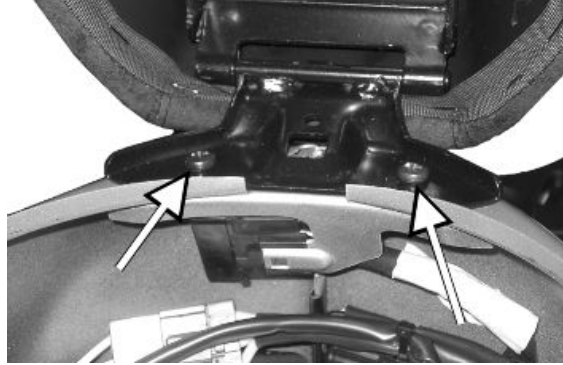

- Remove the helmet compartment
- Remove the 2 nuts indicated in the photograph



- Free the electric cables from the retaining clamps indicated in the photograph

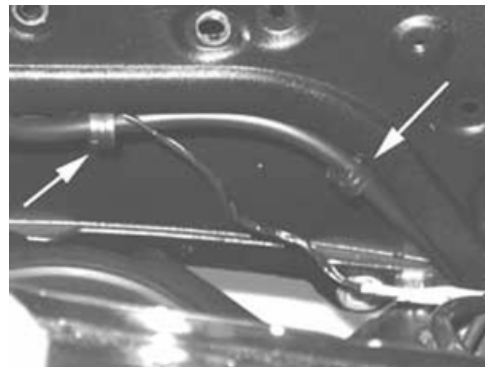

- Remove the saddle opening transmission cable
- Remove the saddle manual opening transmission cable.



- Remove the electric connector from the saddle opening actuator

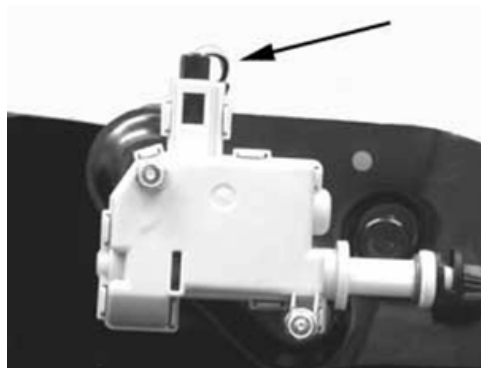

- Remove the two screws shown in the photograph
- Remove the clip from the transmission
- Remove the actuator from the supporting bracket

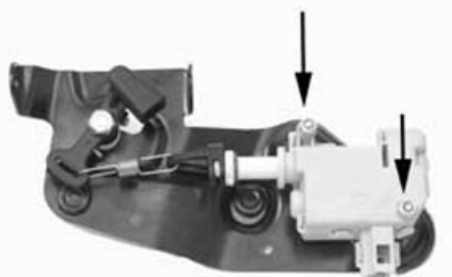

Rear rack

- Remove the helmet compartment
- Remove the 4 screws indicated in the figure

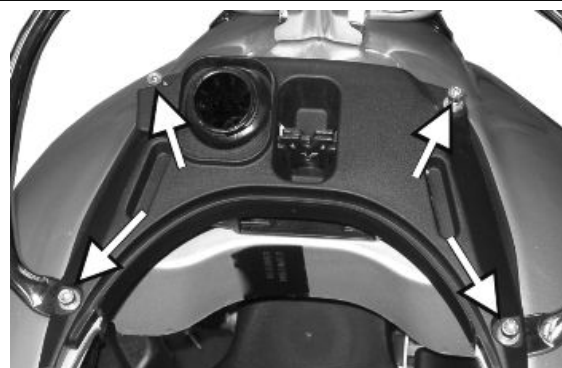

- Remove the two screws, indicated in the figure, that fix the luggage rack to the body

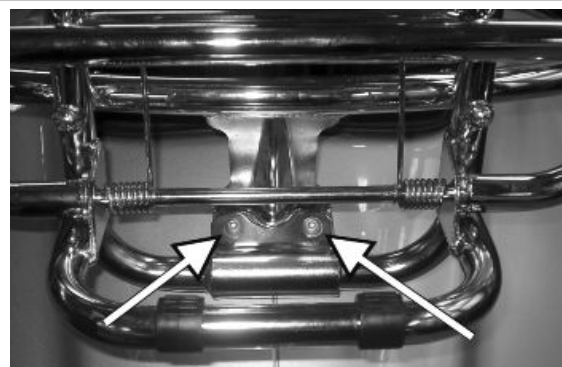

Rear handlebar cover

- Remove the front handlebar cover
- Undo the 5 screws indicated in the photograph
- Disconnect the odometer cable
- After disconnecting the wiring remove the rear handlebar.



Instrument panel

- Remove the rear handlebar cover;
- Remove the four screws indicated in the figure
- Remove the instrument panel.



Front handlebar cover

- Remove the rear-view mirrors.
- Remove the front central cover.
- Remove the front screw indicated in the figure.

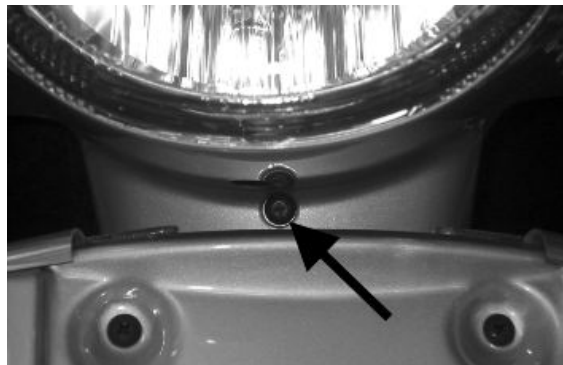

- Undo the 2 screws indicated in the figure;
- Remove the front handlebar cover
- Disconnect the front headlamp connectors



Headlight assy.

- Remove the front handlebar cover.
- Undo the four screws indicated.



- Operate the screw indicated in the figure to remove the front turn indicator



Knee-guard

- Remove the rear handlebar cover.
- Remove the two screws indicated in the photograph and located on the shield under the grille



- Remove the expansion tank cover and then its cap
- Remove the central screw inside the glove-box, indicated in the photograph



- Remove the two screws indicated in the photograph and located below the expansion tank cover and the left cover respectively



- Remove the shield back plate lower screws, to the right and left side of the shield back plate, as indicated in the photograph



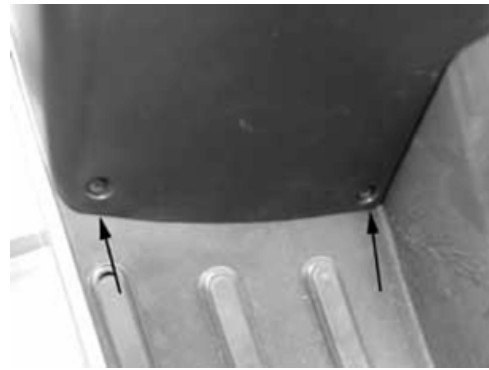

- Remove the electric saddle opening switch, the fuse box and the manual saddle opening cable as shown in the photograph



Taillight assy.

- Operate the screw indicated in the figure to remove the rear turn indicator



Remove screw «A» to remove the rear headlight assembly.

Access to taillight bulbs, stop light bulb and license plate bulb.

To reassemble, repeat the operation in the reverse order.



N.B.

IF MISTING IS NOTICED ON THE INSIDE OF THE HEAD-LAMP GLASS, THIS DOES NOT INDICATE A FAULT AND IS RELATED TO THE HUMIDITY AND/OR TO LOW TEMPERATURES.

THE PHENOMENON SHOULD QUICKLY DISAPPEAR WHEN THE LIGHT IS SWITCHED ON.

THE PRESENCE OF DROPS OF WATER, ON THE OTHER HAND, COULD INDICATE THAT WATER IS INFILTRATING. CONTACT THE PIAGGIO AFTER-SALES SERVICE NETWORK.

Footrest

- Remove the shield back plate
- Remove the battery compartment cover
- Remove the side fairings
- Remove the central screw located under the battery compartment cover as indicated in the figure



- Remove the passenger footrests undoing the two screws indicated in the figure

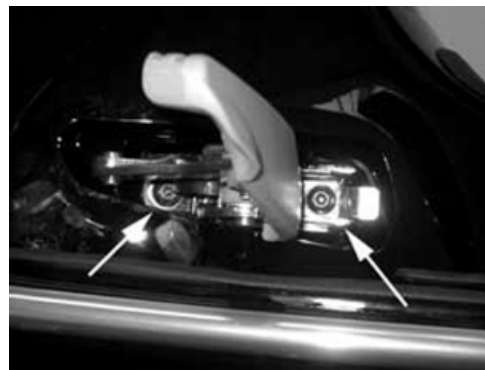

- Remove the right and left screws fixing the footrest indicated in the figure



- Remove the right and left lower covers as shown in the figure



- Remove the screws under the non-slip rubber mat of the footrest as indicated in the photograph



Side fairings

- Unscrew the fixing screw "A"
- Unscrew the nut "B" under the body.



Helmet bay

- Lift the saddle and remove the helmet compartment

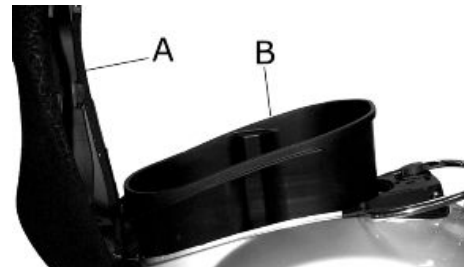

Fuel tank

- Remove the helmet compartment
- Remove the side fairings
- Remove the muffler
- Remove the luggage rack
- Remove the shock absorber upper clamps
- Remove the two screws, indicated in the figure, that fix the tank to the body



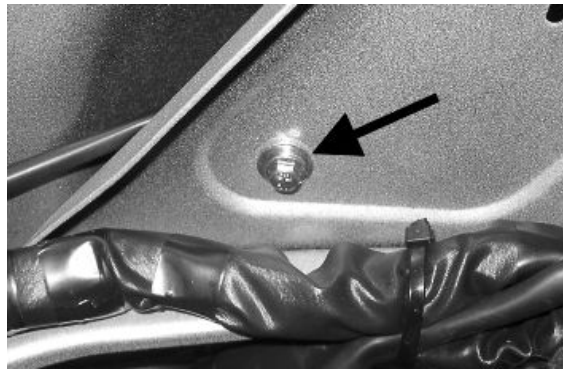

- Remove the screw indicated in the figure that fixes the tank to the body after removing the rear headlight assembly

- Remove the two turn indicators
 - Use a jack to lift the body so that there is enough space between the vehicle rear side and the engine to slide off the tank
- To refit, perform the steps in the reverse direction to disassembly

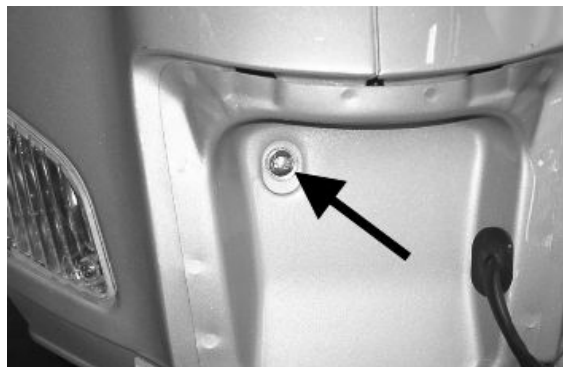

Rear central cover

- Remove the four screws indicated in the figure

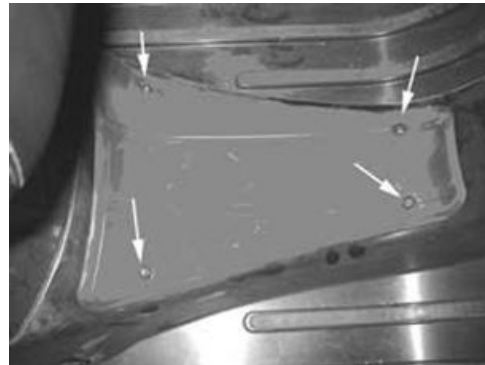

Front mudguard

- First remove the steering tube and uncouple the front brake pipes from the calliper in order to remove the front mudguard
- Remove the three mudguard-steering tube clamps indicated in the figure

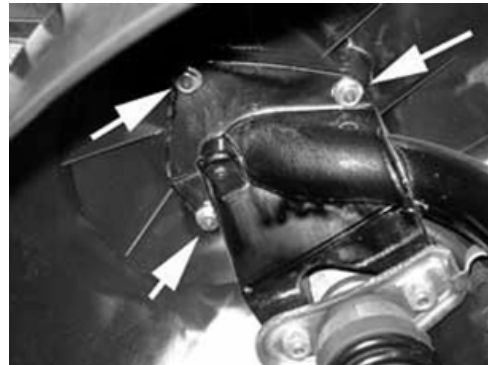

Radiator fan

- In order to carry out any operation on the radiator unit, flow out the coolant in the coolant delivery pipe in the pump, indicated in the photograph.



- Remove the shield back plate;
- Remove the coolant feed and return hoses from the right radiator;
- Unscrew the 4 screws fixing the radiator to the body;
- Detach the radiator



- Detach the pipe from the plastic duct by removing the plastic clip shown in the photograph. Then remove the duct.

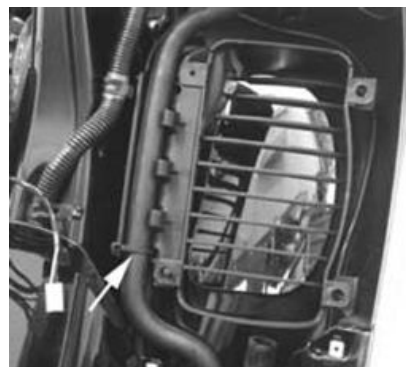

-
- The same procedure also applies to the left radiator for which it is necessary to remove the electric fan first by undoing the three screws indicated in the photograph and afterwards disconnect the connector.

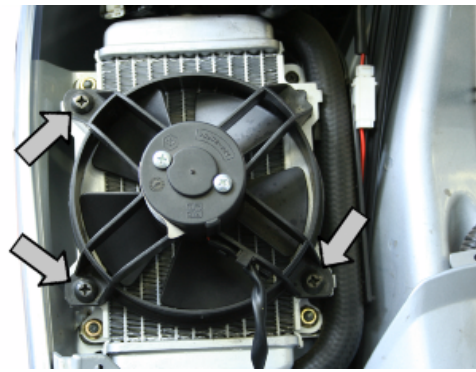

To refit, perform the removal operations but in reverse order being careful when positioning the new clips for the fluid hoses and when filling the cooling system.

Front central cover

- Remove the "PIAGGIO" clip-on badge
- Unscrew the screw indicated in the figure
- Remove the grille

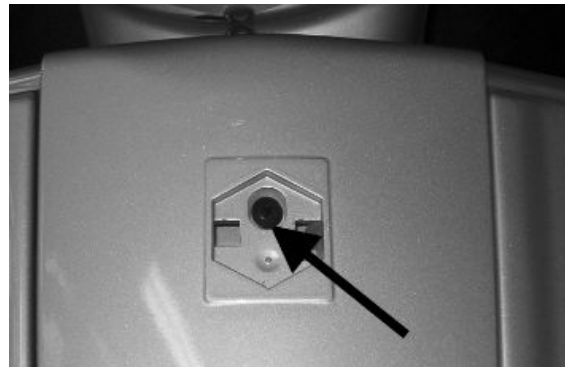

INDEX OF TOPICS

PRE-DELIVERY

PRE DE

Carry out the listed tests before delivering the vehicle.

Warning- be very careful when handling fuel.

Aesthetic inspection

Appearance check:

- Paintwork
 - Fitting of plastics
 - Scratches
 - Dirt
-

Tightening torques inspection

Lock check

- Safety locks
- clamping screws

Safety locks

Rear shock absorber upper fixing

Rear shock absorber lower fixing

Lower front shock absorber fitting

Front wheel axle nut

Front wheel screws

Rear wheel screws

Front and rear wheel hub nut

Front and rear brake calliper clamping screws

Frame - swinging arm bolt *

Swinging arm bolt - Engine

Engine arm pin - Frame arm

Handlebar lock nut

Steering lower ring nut

Upper steering ring nut

Electrical system

- Main switch
 - Lights: high beams, low beams, side/taillights (front and rear) and relevant warning lights
 - Regulating the headlights according to the regulations currently in force
 - Front and rear stop light buttons and relative light •Turn indicators and relative telltales
 - Instrument lighting
 - instruments: fuel and temperature indicator
-

- Instrument panel lights
- Horn
- electric start up
- Engine stopping with emergency stop switch
- electric saddle opening button

CAUTION

TO ENSURE MAXIMUM PERFORMANCE, THE BATTERY MUST BE CHARGED BEFORE USE. INADEQUATE CHARGING OF THE BATTERY WITH A LOW LEVEL OF ELECTROLYTE BEFORE IT IS FIRST USED SHORTENS BATTERY LIFE.

CAUTION

WHEN INSTALLING THE BATTERY, ATTACH THE POSITIVE LEAD FIRST AND THEN THE NEGATIVE LEAD.

WARNING

BATTERY ELECTROLYTE IS TOXIC AND IT MAY CAUSE SERIOUS BURNS. IT CONTAINS SULPHURIC ACID. AVOID CONTACT WITH EYES, SKIN AND CLOTHING.

IN CASE OF CONTACT WITH EYES OR SKIN, RINSE WITH ABUNDANT WATER FOR ABOUT 15 MINUTES AND SEEK MEDICAL ATTENTION AT ONCE.

IF IT IS SWALLOWED, IMMEDIATELY DRINK LARGE QUANTITIES OF WATER OR VEGETABLE OIL. SEEK IMMEDIATE MEDICAL ATTENTION.

BATTERIES PRODUCE EXPLOSIVE GAS; KEEP THEM AWAY FROM NAKED FLAMES, SPARKS AND CIGARETTES. IF THE BATTERY IS CHARGED IN A CLOSED PLACE, TAKE CARE TO ENSURE ADEQUATE VENTILATION. ALWAYS PROTECT YOUR EYES WHEN WORKING CLOSE TO BATTERIES.

KEEP OUT OF THE REACH OF CHILDREN

CAUTION

NEVER USE FUSES WITH A CAPACITY HIGHER THAN THE RECOMMENDED CAPACITY. USING A FUSE OF UNSUITABLE RATING MAY SERIOUSLY DAMAGE THE VEHICLE OR EVEN CAUSE A FIRE.

Levels check

Level check:

- Hydraulic brake system liquid level.
- Rear hub oil level
- Engine coolant level
- Engine oil level

Road test

Test ride

- Cold start
- Instrument operations
- Response to the throttle control
- Stability on acceleration and braking
- Rear and front brake efficiency
- Rear and front suspension efficiency

- Abnormal noise

Static test

Static control after the test ride:

- Hot engine restart
- Minimum seal (turning the handlebar)
- Uniform steering rotation
- Possible losses
- electric radiator fan operation

CAUTION

CHECK AND ADJUST TYRE PRESSURE WITH TYRES AT AMBIENT TEMPERATURE.

CAUTION

NEVER EXCEED THE RECOMMENDED INFLATION PRESSURES OR TYRES MAY BURST.

Functional inspection

Functional check up:

- Hydraulic braking system: lever travel
 - Clutch: proper functioning check
 - Engine: proper general functioning and no abnormal noise check
 - Other: papers check, frame and engine number check, tools and equipment, licence plate fitting, lock check, tyre pressure check, rear-view mirror and any accessory fitting
-

INDEX OF TOPICS

TIME

TIME

This section is devoted to the time necessary to carry out repairs.

For each operation, the description, code and time envisages are specified.

Engine

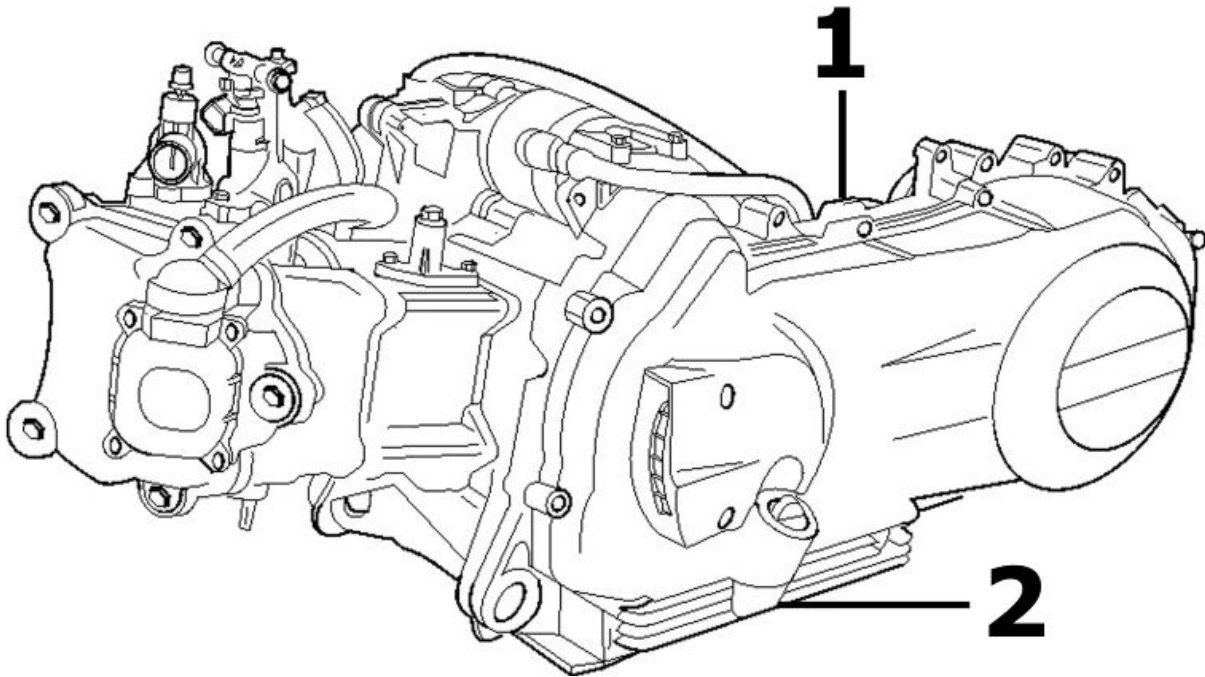

ENGINE

	<u>Code</u>	<u>Action</u>	<u>Duration</u>
1	001001	Engine from frame - Removal and re-fit.	
2	003064	Engine oil - Change	

Crankcase

CRANKCASE

	<u>Code</u>	<u>Action</u>	<u>Duration</u>
1	001153	Crankcase halves gasket - Replacement	
2	001133	Engine crankcase- Replacement	

Crankshaft

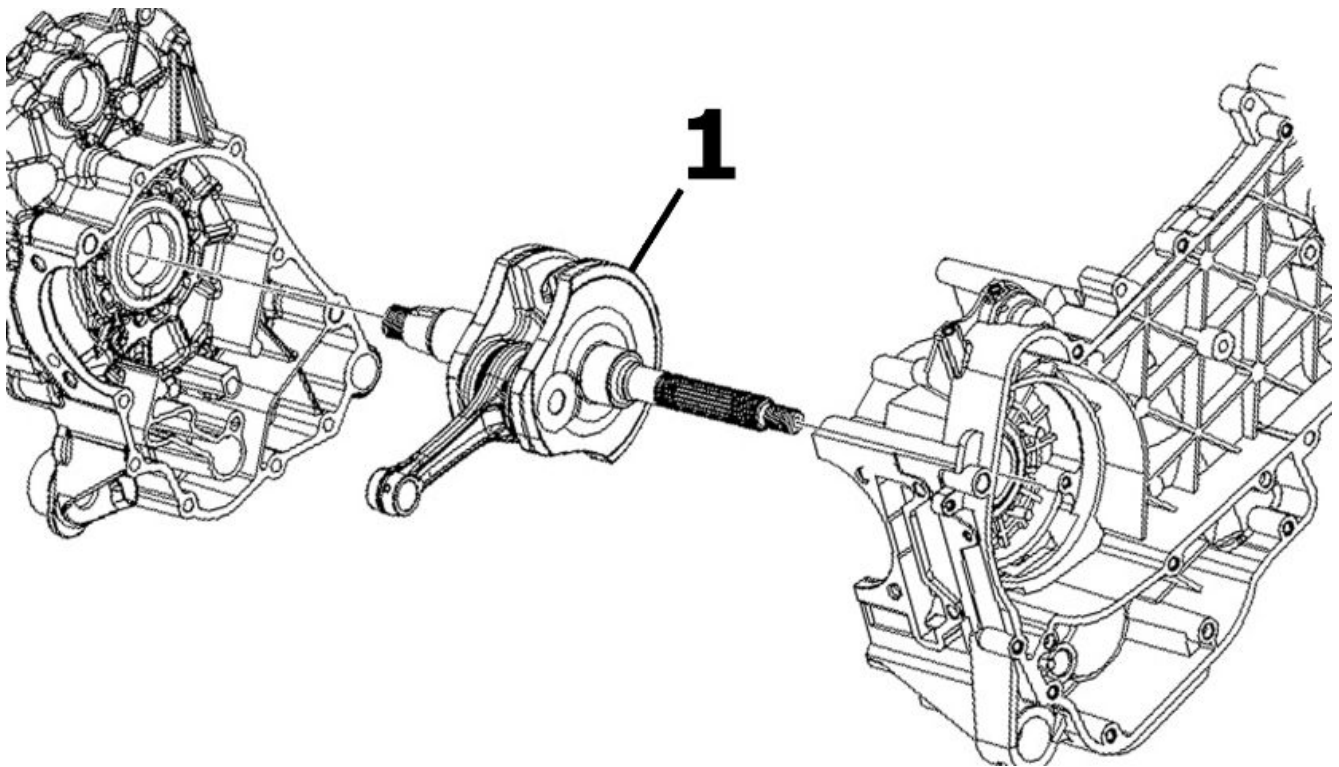

CRANKSHAFT

	Code	Action	Duration
1	001117	Crankshaft - Replacement	

Cylinder assy.

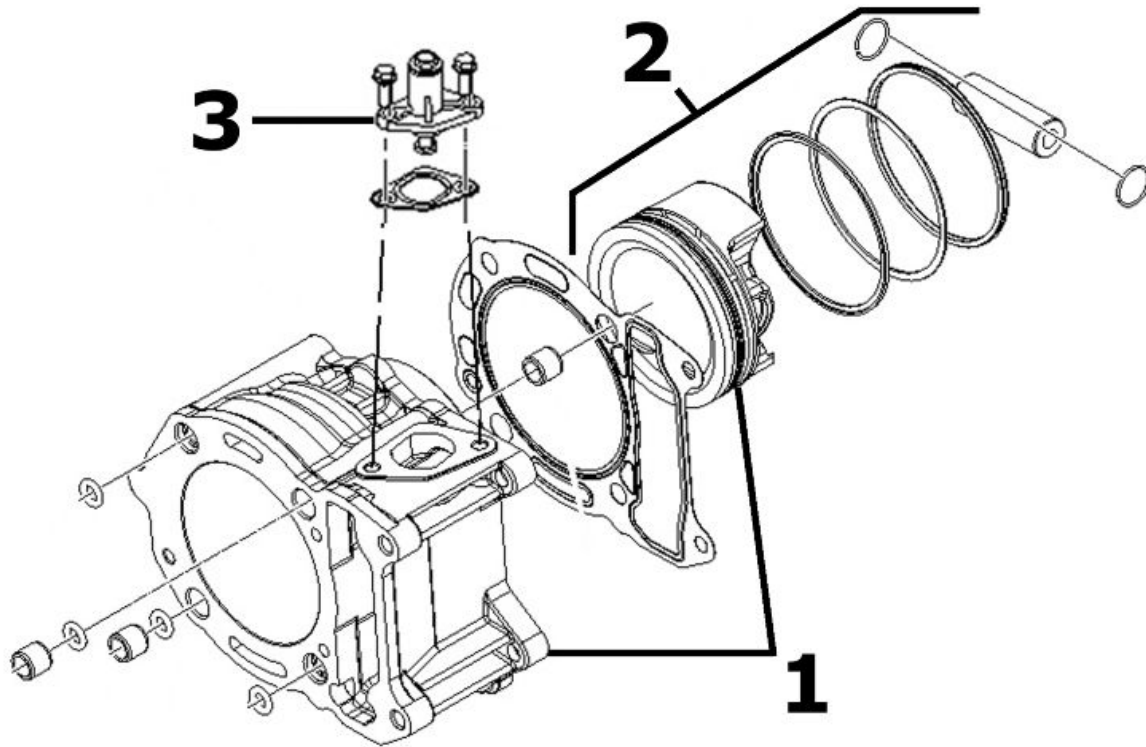
**CYLINDER- PISTON**

	Code	Action	Duration
1	001002	Cylinder-Piston - Replacement	
2	001154	Pin-ring-piston assembly - Service	
3	001129	Chain tightener - Overhaul and replacement	

Cylinder head assy.

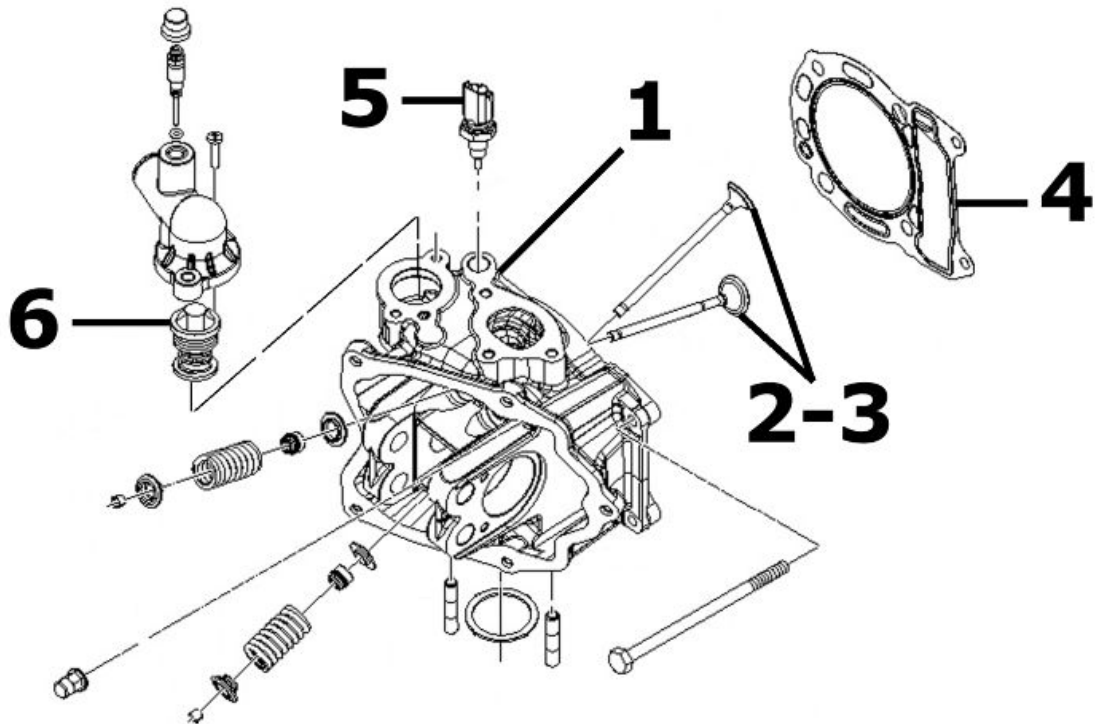

VALVE HEAD

	Code	Action	Duration
1	001126	Head - Replacement	
2	001045	Valves - Replacement	
3	001049	Valves - Adjustment	
4	001056	Head gasket - Replacement	
5	001083	Thermistor - Replacement	
6	001057	Thermostat - Replacement	

Rocker arms support assy.

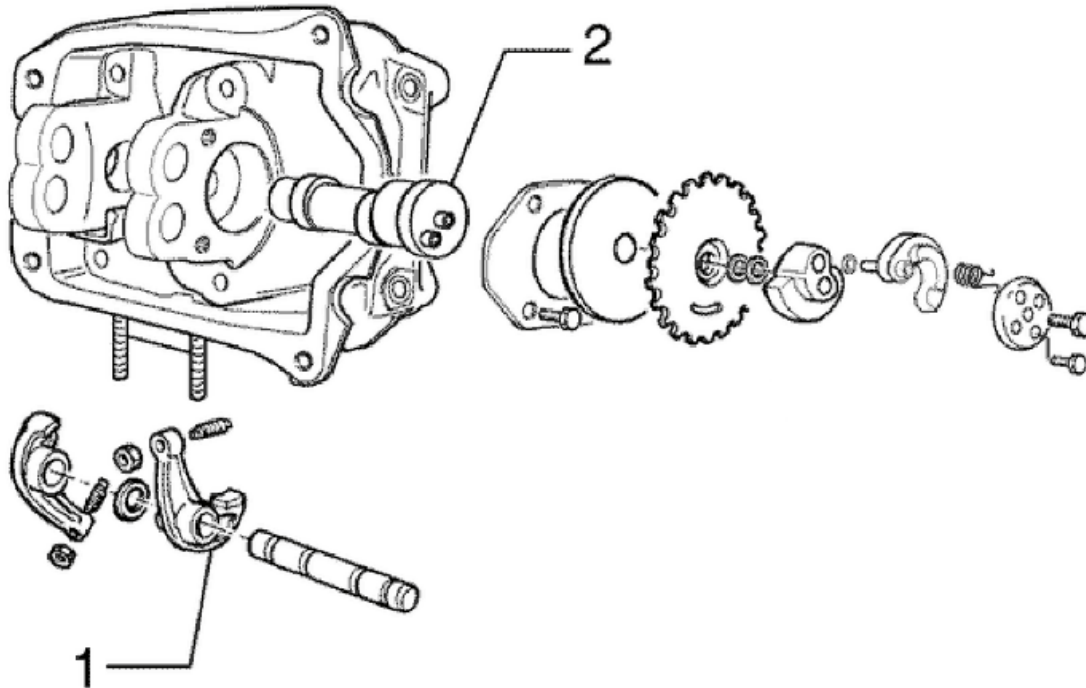

CAMSHAFT

	Code	Action	Duration
1	001148	Rocking lever valve - Replacement	
2	001044	Camshaft - Replacement	

Cylinder head cover

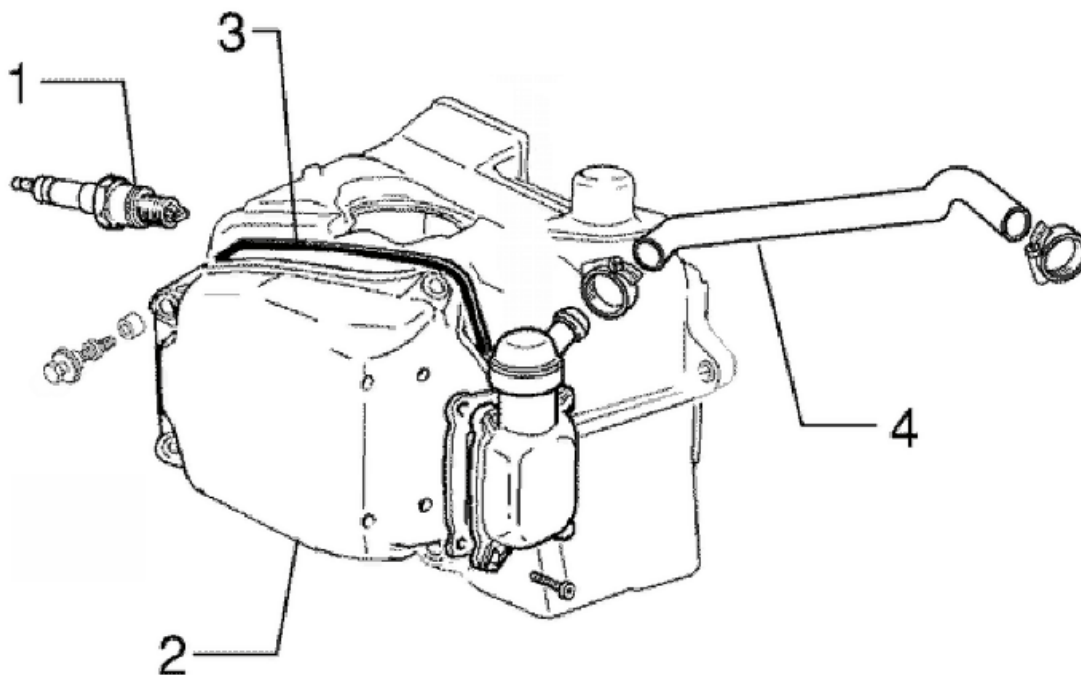

HEAD COVER

	Code	Action	Duration
1	001093	Spark plug - Replacement	
2	001089	Head cover - Replacement	
3	001088	Head cover gasket - Replacement	
4	001074	Oil vapour recovery pipe - Replacement	

Oil filter

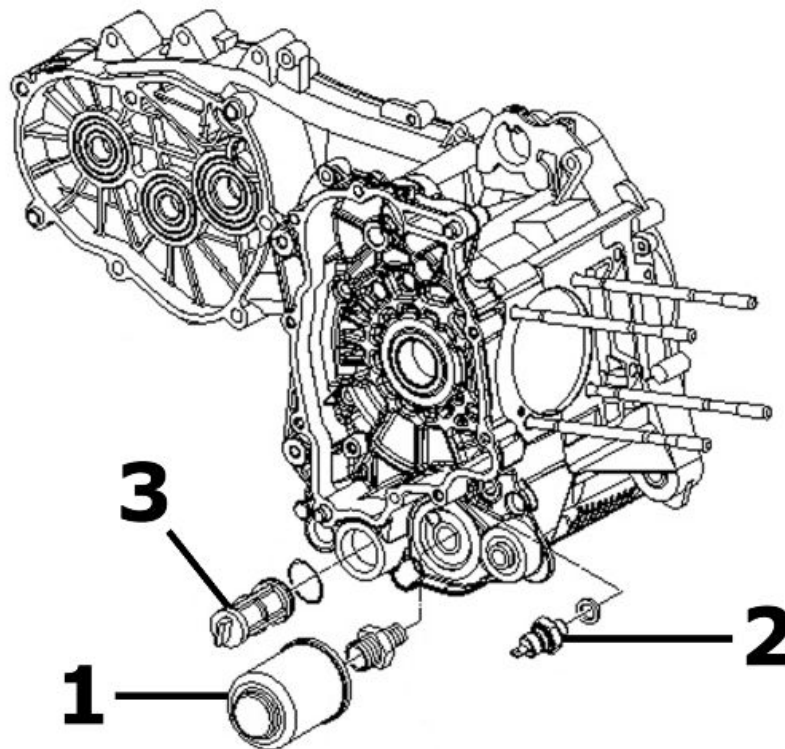

OIL FILTER

	Code	Action	Duration
1	001123	Oil filter -Replacement	
2	001160	Oil pressure sensor - Replacement	
3	001102	Net oil filter - Replacement / Cleaning	

Flywheel cover

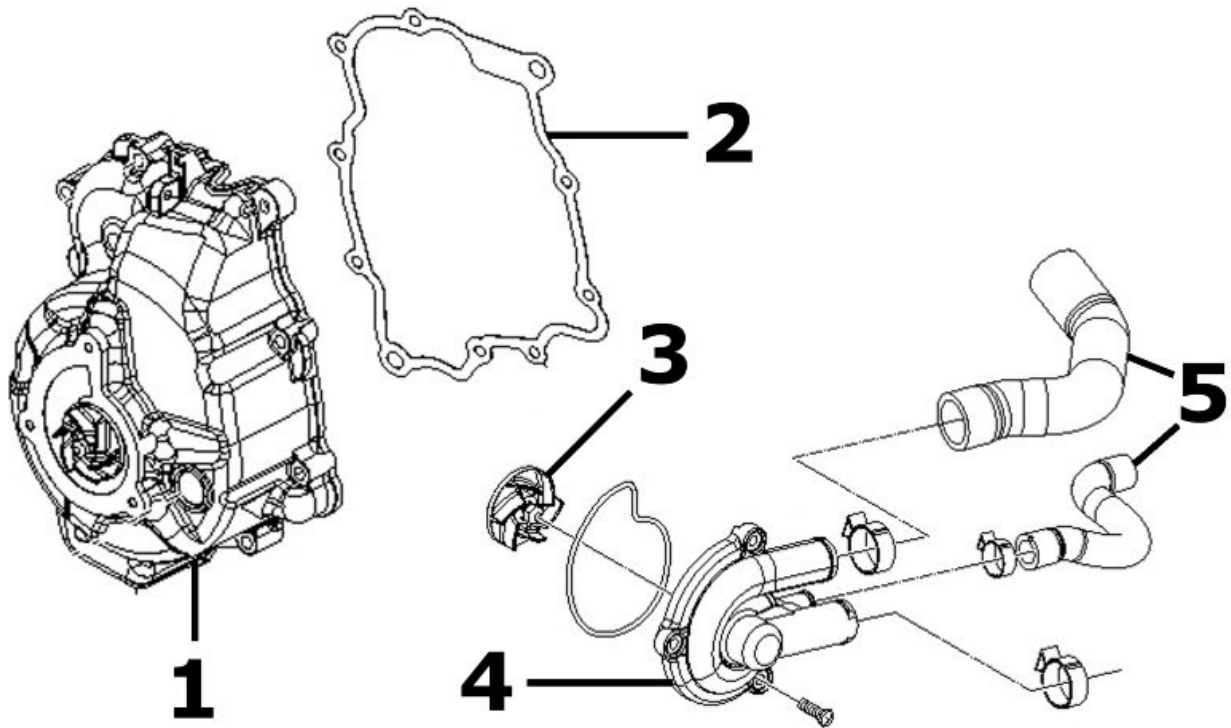

FLYWHEEL COVER

	Code	Action	Duration
1	001087	Flywheel cover - Replacement	
2	001150	Flywheel cover gasket - Replacement	
3	007007	Water pump rotor - Replacement	
4	007017	Water pump cover - Replacement	
5	007003	Coolant delivery and return pipe - Replacement	

Driven pulley

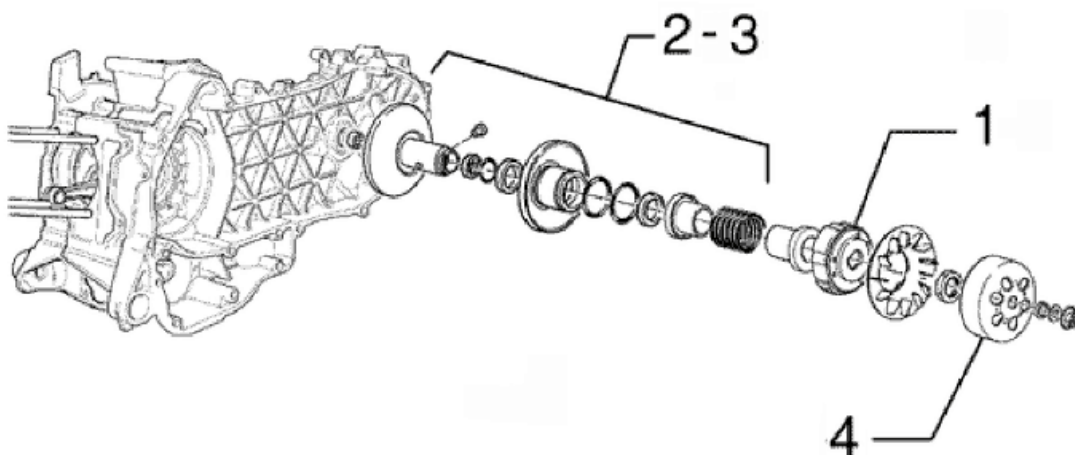

DRIVEN PULLEY

	Code	Action	Duration
1	001022	Clutch - Replacement	
2	001012	Driven pulley - Service	
3	001110	Driven pulley - Replacement	
4	001155	Clutch bell - Replacement	

Oil pump

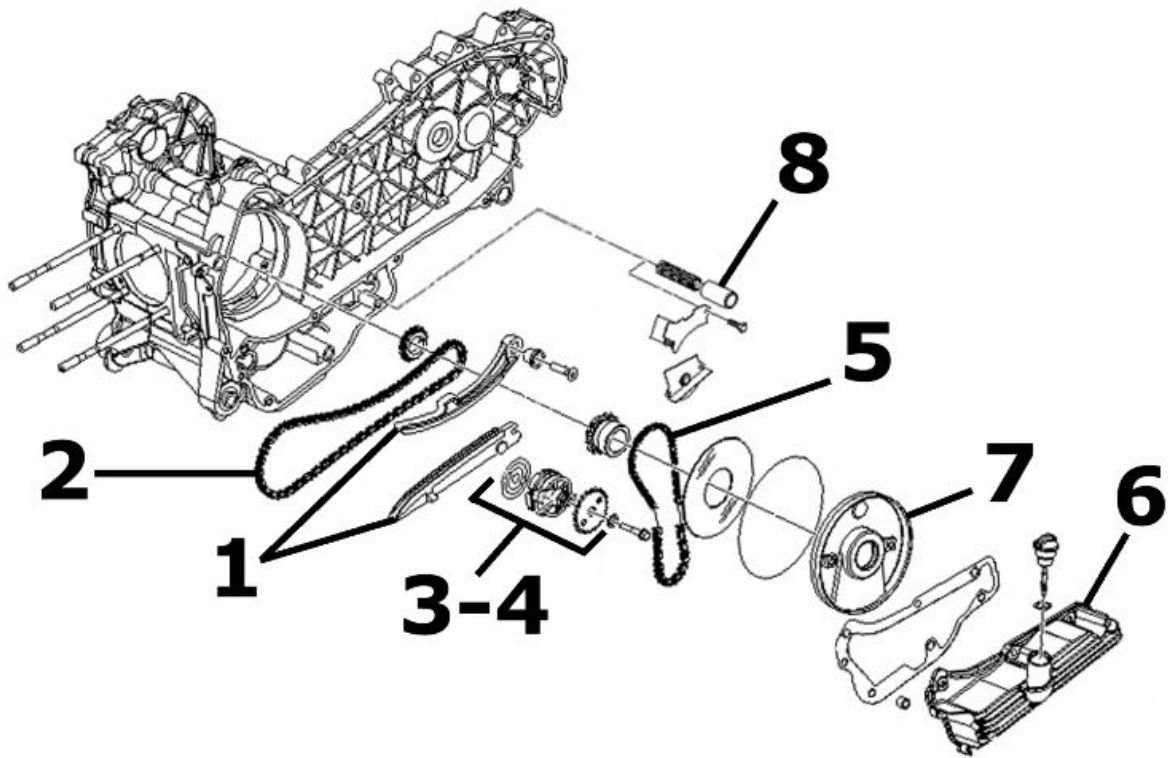

OIL PUMP

	Code	Action	Duration
1	001125	Chain guide pads - Replacement	
2	001051	Belt/Timing chain - Change	
3	001042	Oil pump - Service	
4	001112	Oil pump - change	
5	001122	Oil pump chain - Replacement	
6	001130	Oil sump - Replacement	
7	001172	Chain cover flap - change	
8	001124	Lubrication by-pass - Replacement	

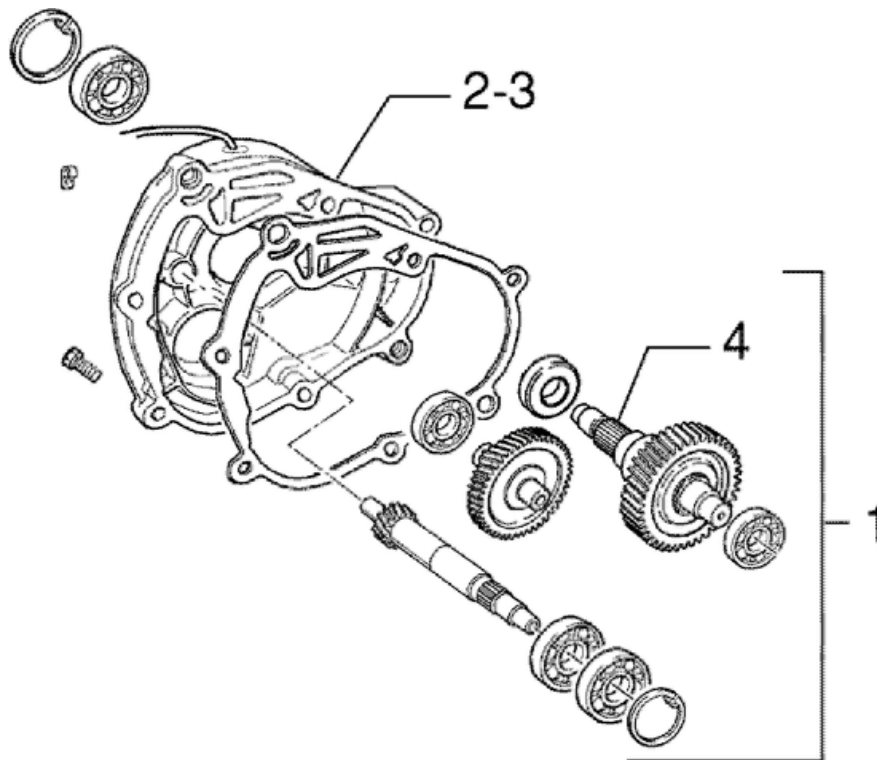
Final gear assy.**FINAL REDUCTION**

	Code	Action	Duration
1	001010	Reduction gear - Replacement	
2	003065	Gear box oil - Replacement	
3	001156	Geared reduction unit cover - Replacement	
4	004125	Rear wheel axle - Replacement	

Driving pulley

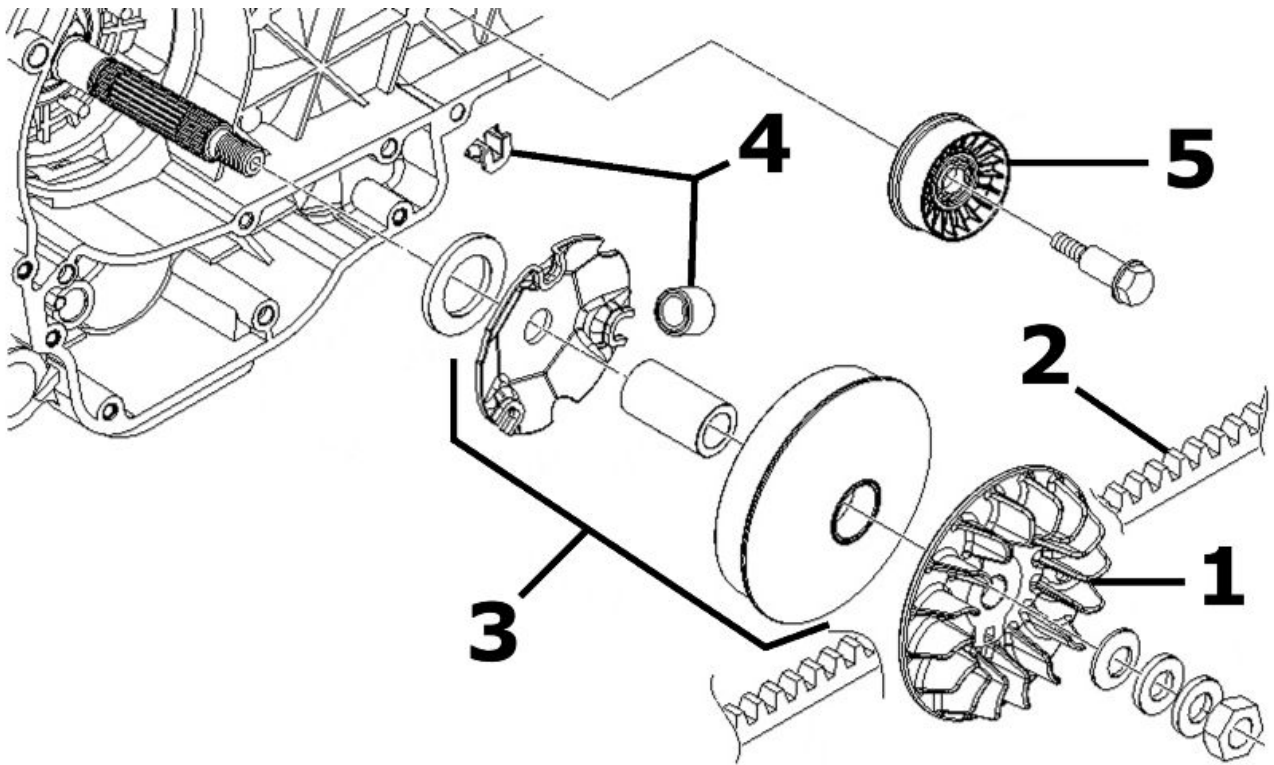

DRIVING PULLEY

	Code	Action	Duration
1	001086	Driving half-pulley - Replacement	
2	001011	Driving belt - Replacement	
3	001066	Driving pulley - Removal and refitting	
4	001177	Variator rollers / shoes - Replacement	
5	001141	Belt anti-flapping roller - Replacement	

Transmission cover

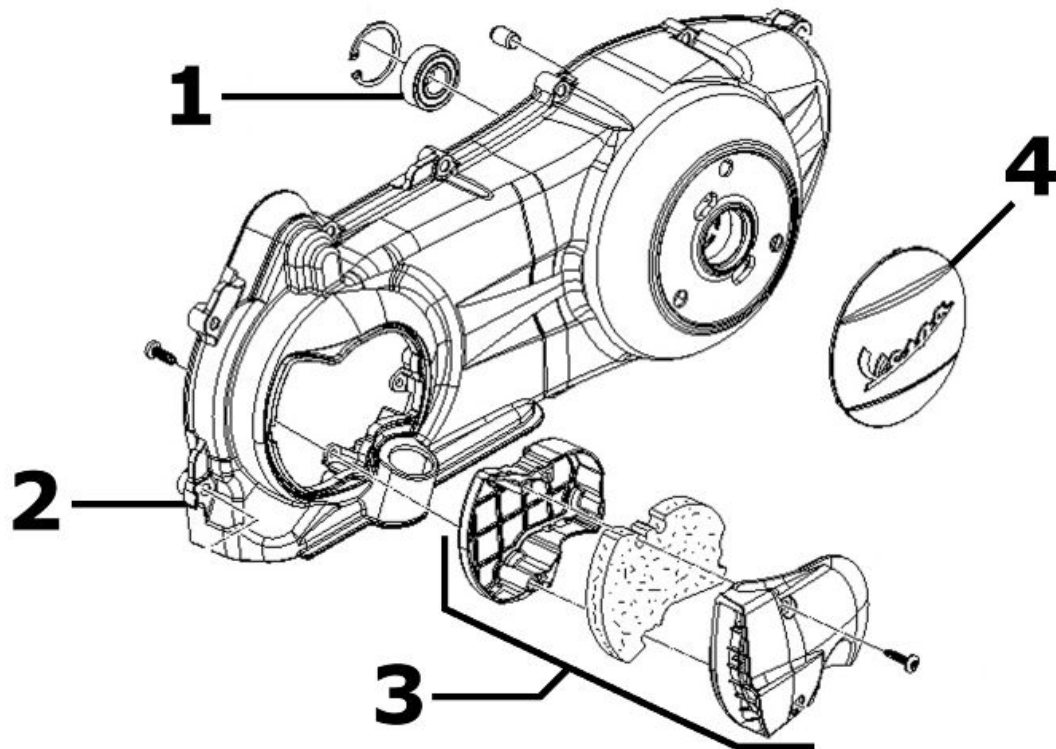
**TRANSMISSION COVER**

	Code	Action	Duration
1	001135	Transmission cover bearing - Replacement	
2	001096	Transmission crankcase cover - Replacement	
3	001131	Transmission air intake - Replacement	
4	001065	Transmission cover - Replacement	

Starter motor

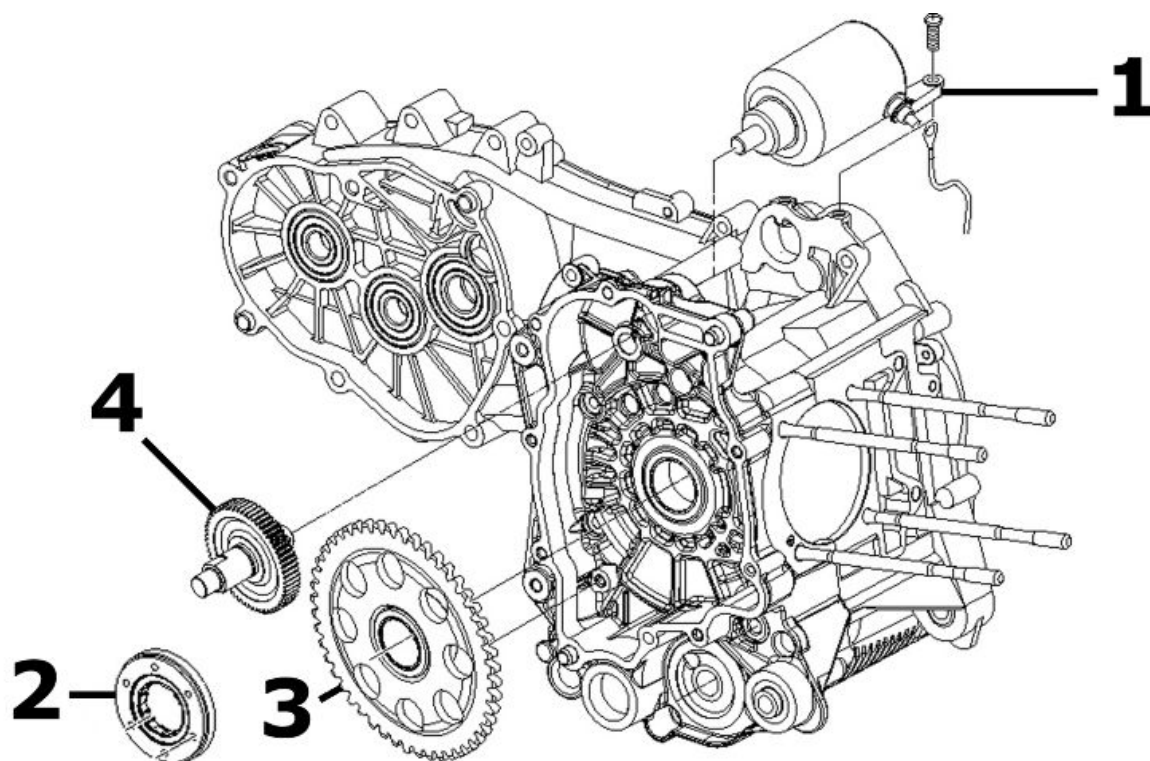

ELECTRICAL START-UP

	Code	Action	Duration
1	001020	Starter motor - Replacement	
2	001104	Start-up freewheel - Replacement	
3	001151	Start-up driven gearing - Replacement	
4	001017	Start-up pinion - Replacement	

Flywheel magneto

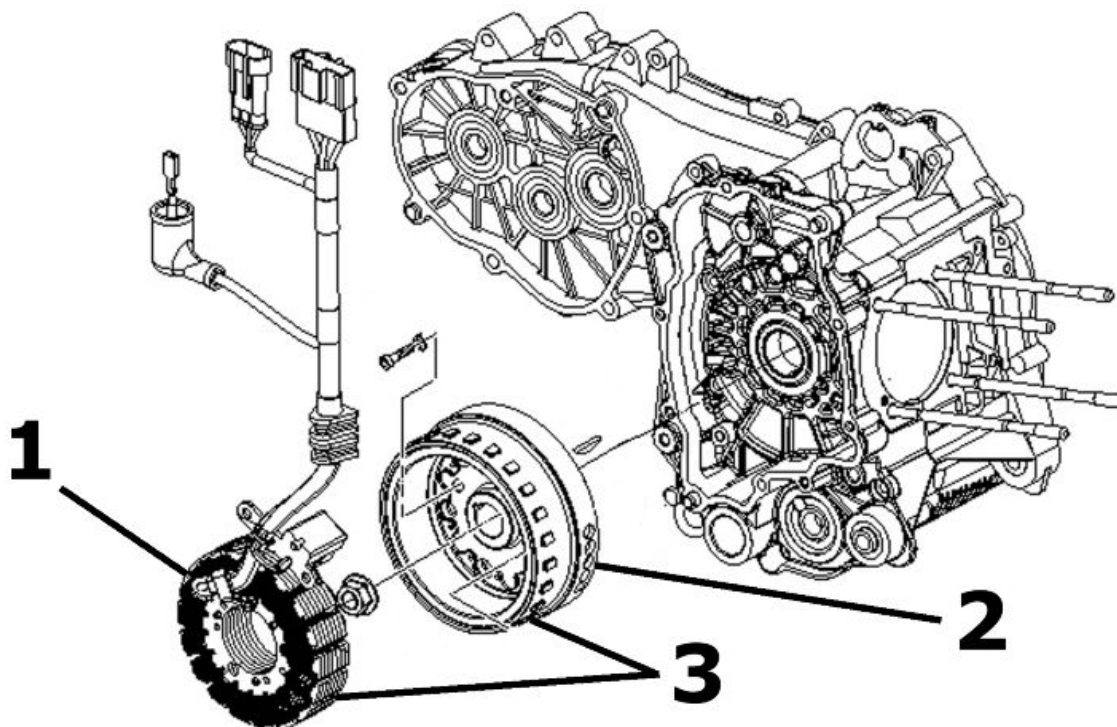
**MAGNETO FLYWHEEL**

	Code	Action	Duration
1	001067	Stator - Removal and Refitting	
2	001173	Rotor - Replacement	
3	001058	Complete flywheel - Replacement	

Butterfly valve

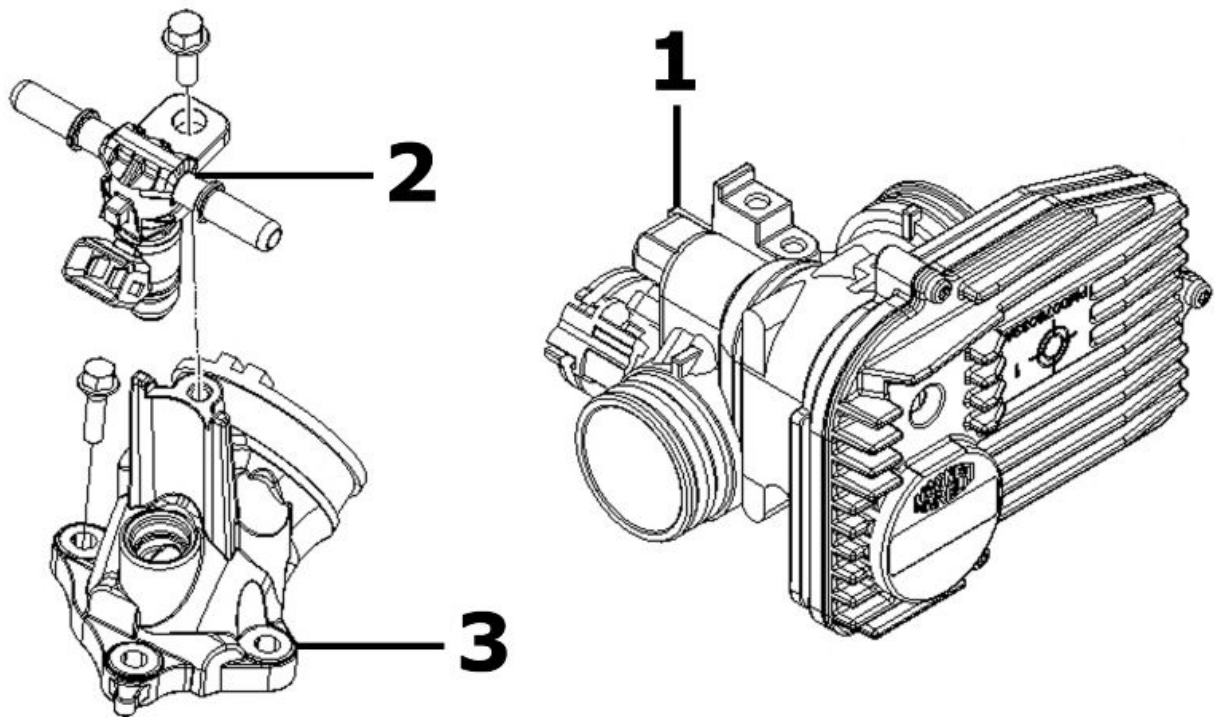

THROTTLE BODY

	Code	Action	Duration
1	001166	Throttle body - Replacement	
2	001047	Injector - Replacement	
3	001013	Intake manifold - Replacement	

Exhaust pipe

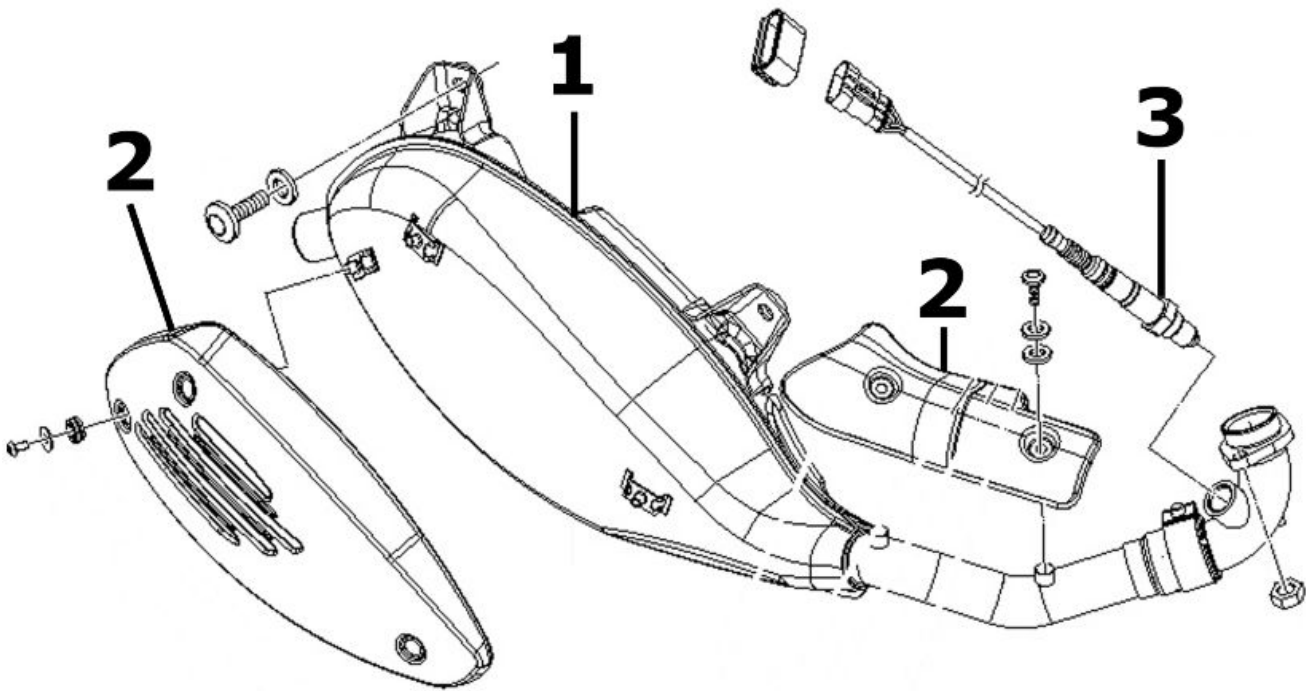
**MUFFLER**

	Code	Action	Duration
1	001009	Muffler - Replacement	
2	001095	Muffler guard - Replacement	
3	005138	Lambda probe - Replacement	

Air cleaner

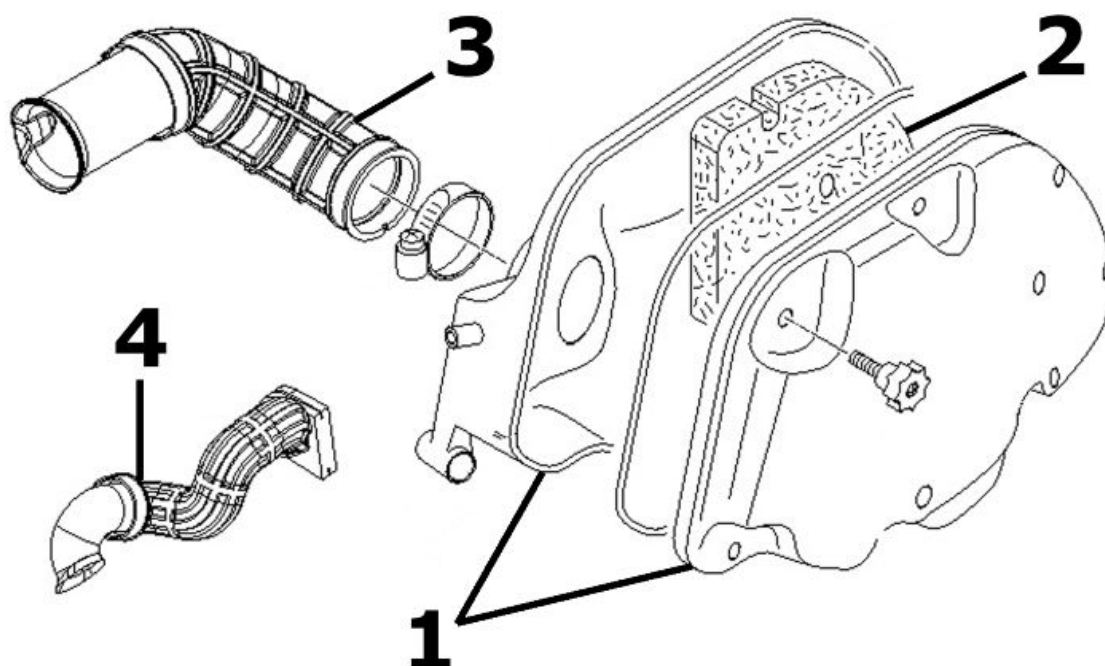

AIR CLEANER

	Code	Action	Duration
1	001015	Air filter box - Replacement	
2	001014	Air filter - Replacement / cleaning	
3	004122	Air cleaner/ carburettor union - Replacement	
4	001027	Body / air cleaner union - Replacement	

Frame

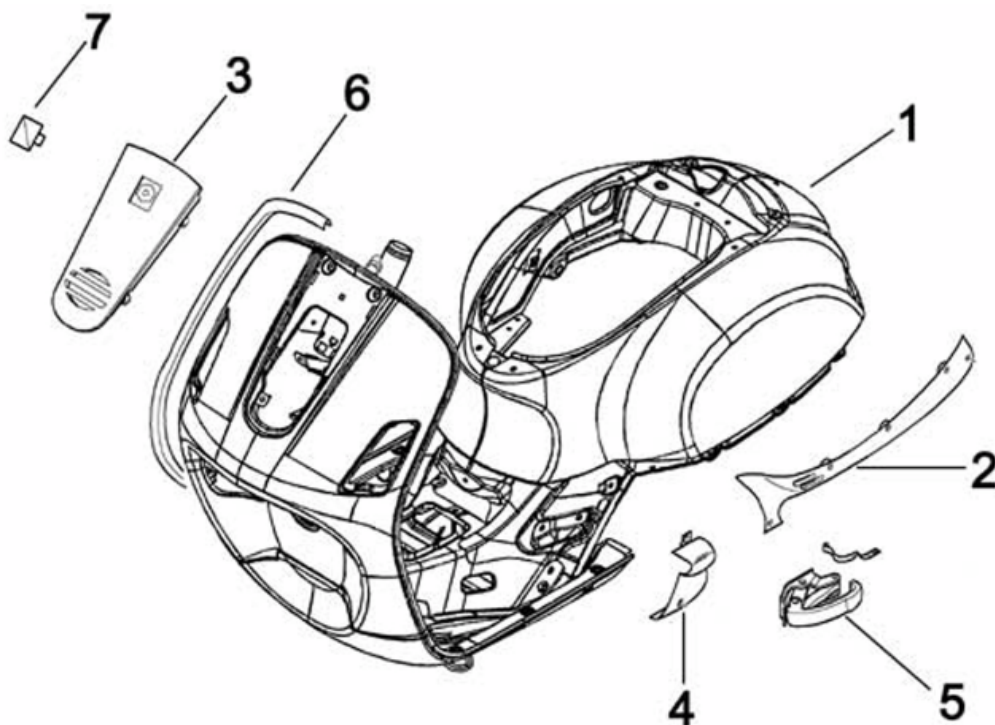
**CHASSIS**

	Code	Action	Duration
1	004001	Chassis - Replacement	
2	004085	Fairing (1) - Replacement	
3	004149	Shield central cover - Replacement	
4	004053	Spoiler - Replacement	
5	004015	Footrest - Removal and Refitting	
6	004023	Shield rim - Replacement	
7	004159	Plates / Stickers - Replacement	

Centre-stand

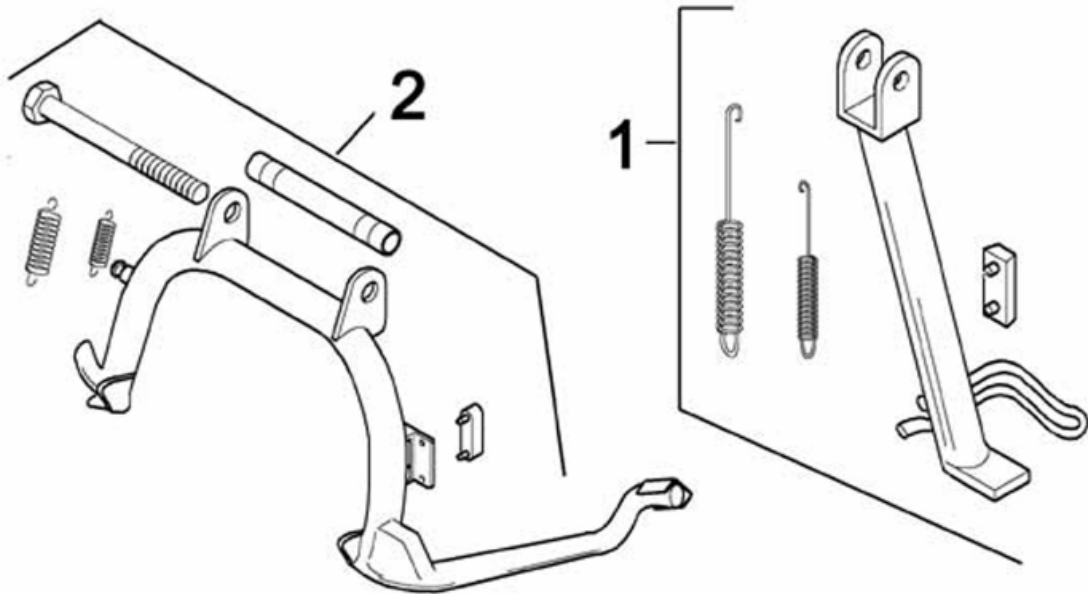

STAND

	Code	Action	Duration
1	004102	Side stand - Replacement	
2	004004	Stand - Replacement	

Footrests

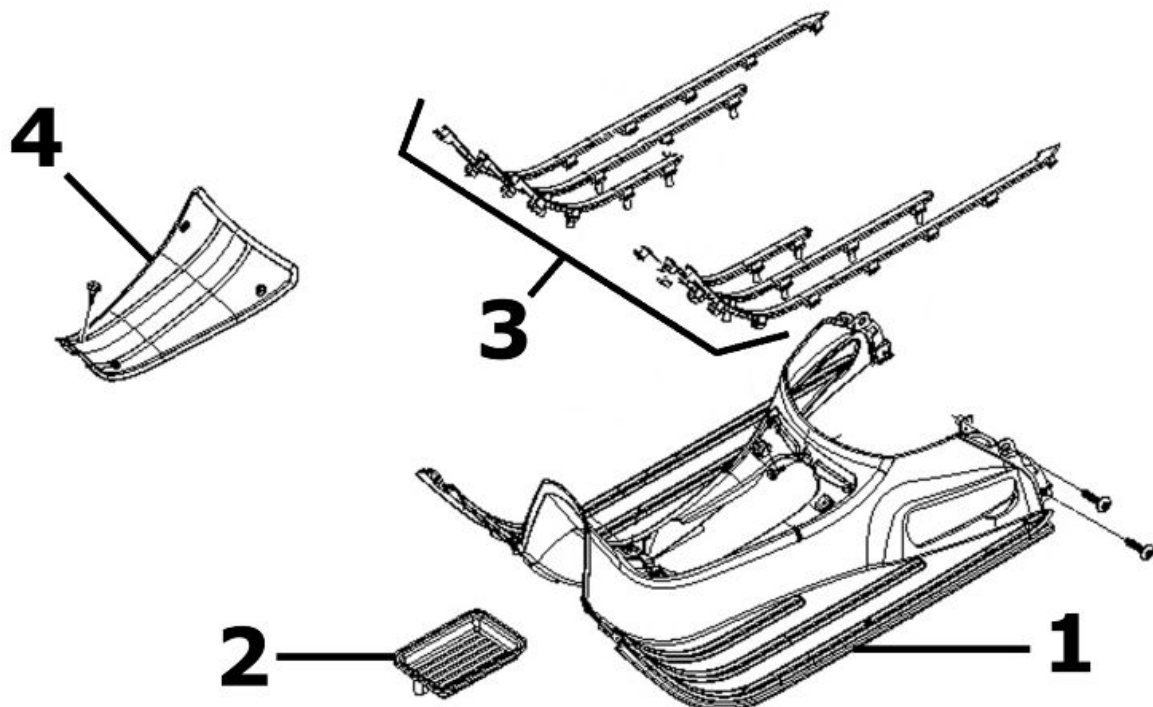

MATS AND COVERS

	Code	Action	Duration
1	004079	Footrest - replacement	
2	004071	Battery compartment - replacement	
3	004078	Front/rear footrest rubber - Replacement	
4	005046	Battery cover - change	

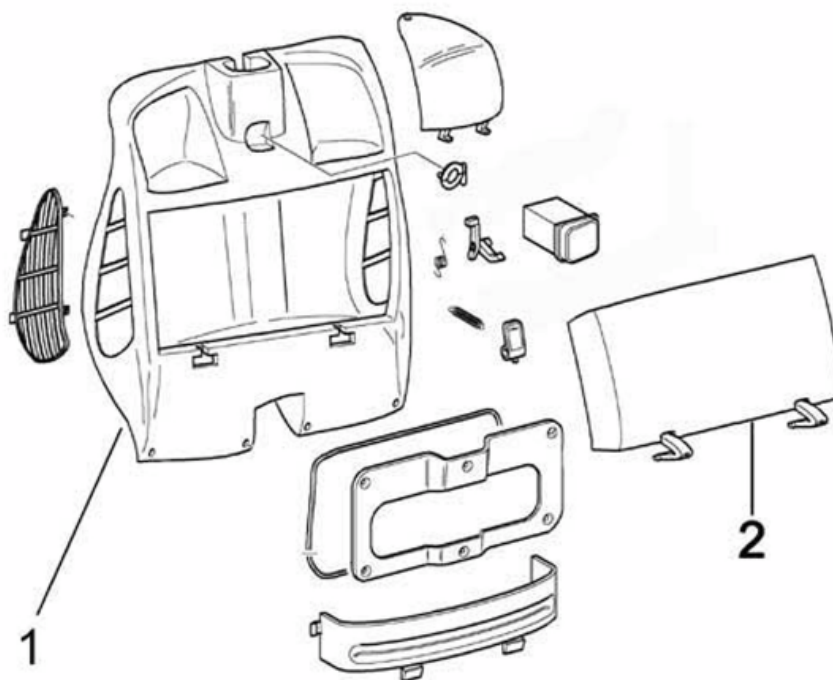
Rear cover**REAR SHIELD**

	Code	Action	Duration
1	004083	Glove box - Replacement	
2	004081	Glove box door - Replacement	

Underseat compartment

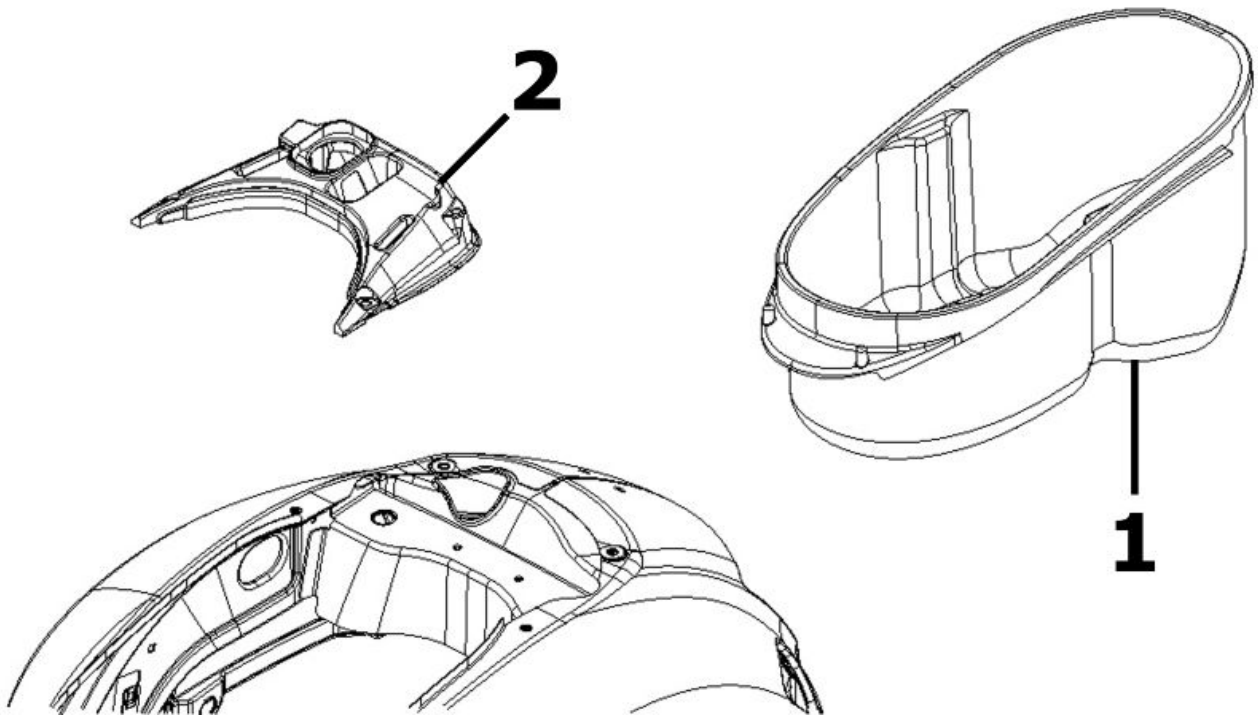

HELMET COMPARTMENT

	Code	Action	Duration
1	004016	Helmet compartment - Removal and Refitting	
2	004011	Central chassis cover - Replacement	

Plate holder

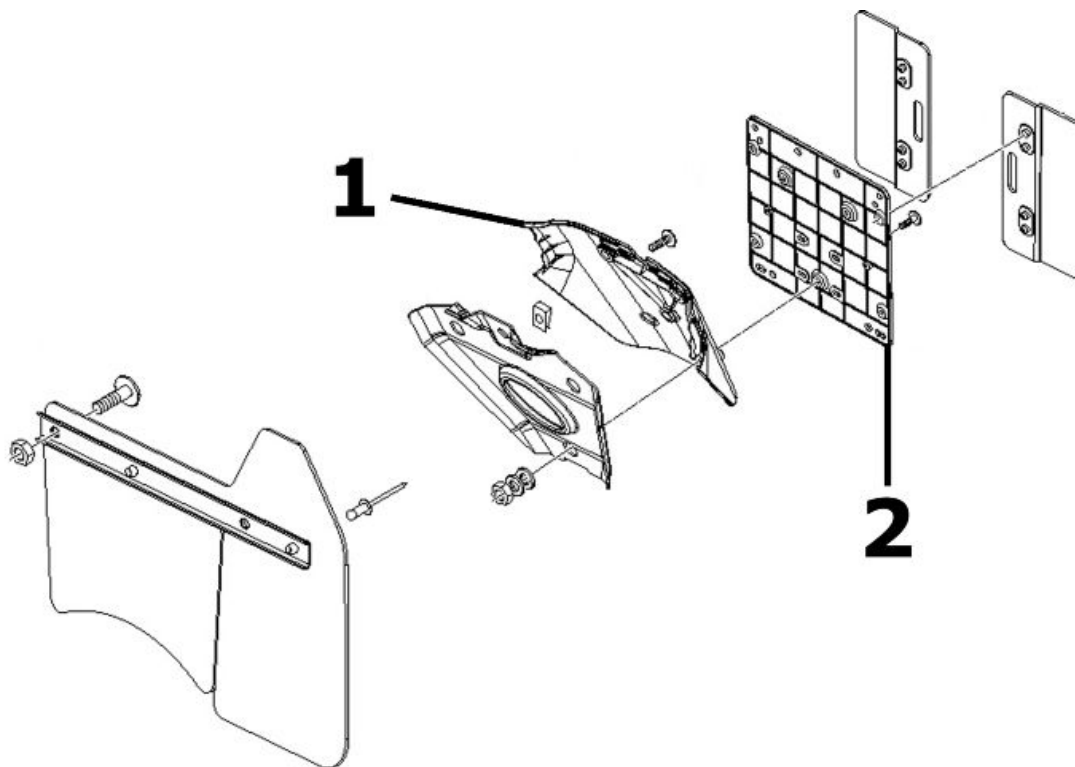

LICENSE PLATE HOLDER

	Code	Action	Duration
1	004136	License plate holder support - Replacement	
2	005048	Licence plate holder - Replacement	

Mudguard

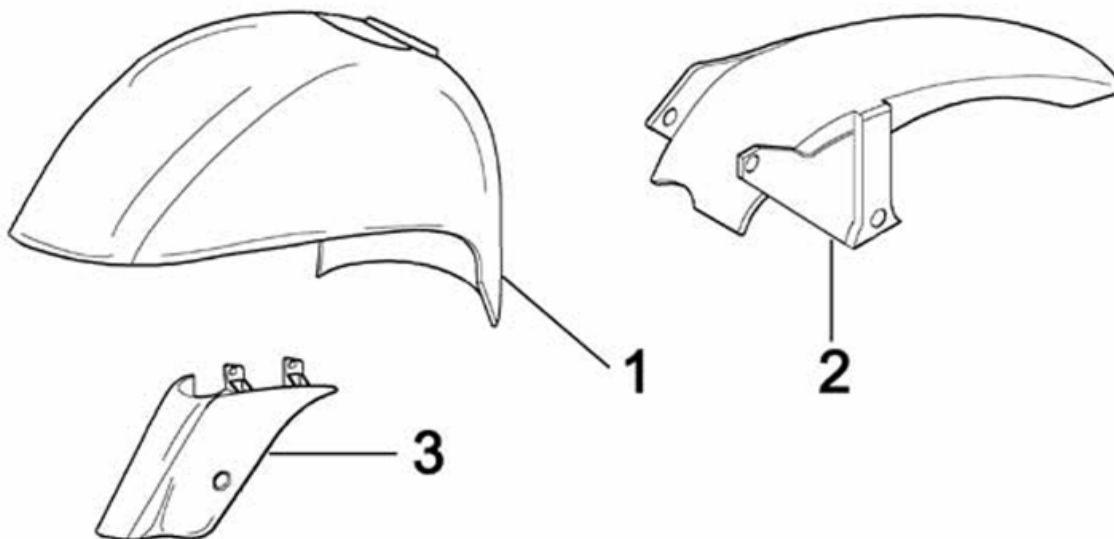

MUDGUARDS

	Code	Action	Duration
1	004002	Front mudguard - Replacement	
2	004009	Rear mudguard - Replacement	
3	003044	Shock absorber cover - Replacement	

Fuel tank

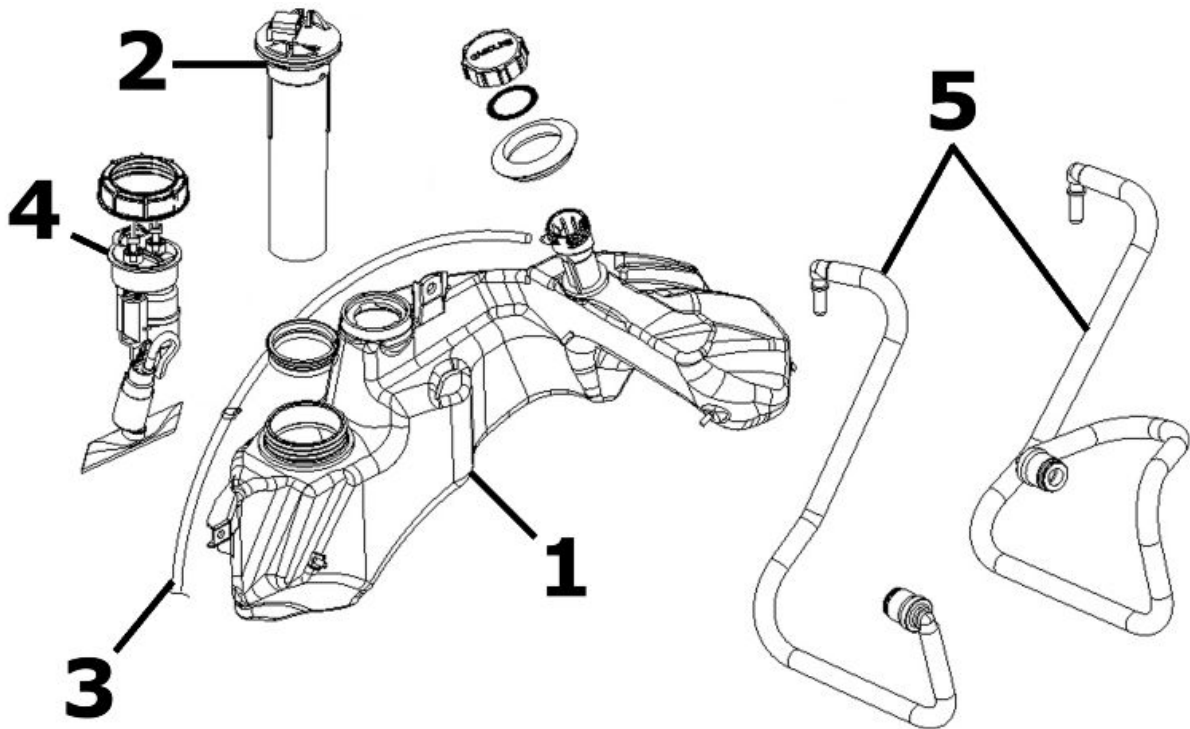

FUEL TANK

	Code	Action	Duration
1	004005	Fuel tank - Replacement	
2	005010	Tank float - Replacement	
3	004109	Fuel tank breather - Replacement	
4	004073	Fuel pump - Replacement	
5	004137	Injector pump pipe - Replacement	

Radiator

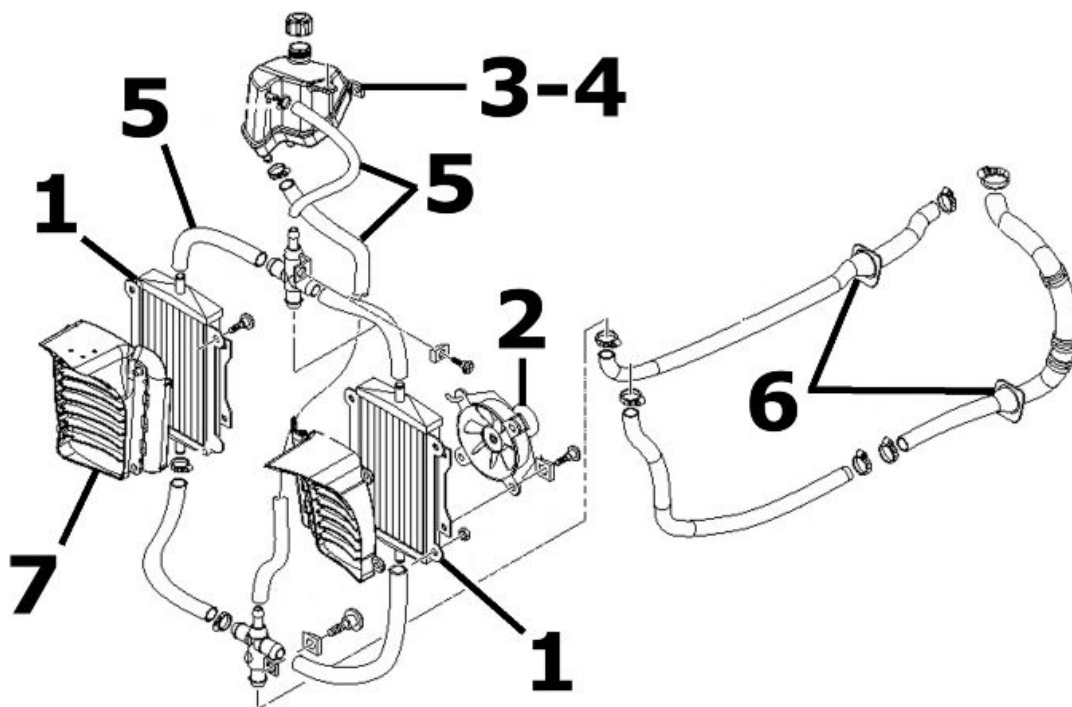
**RADIATOR**

	Code	Action	Duration
1	007002	Water cooling radiator - Replacement	
2	007016	Fan complete with support - Replacement	
3	007001	Expansion tank - Replacement	
4	001052	Coolant and air bleed - Replacement	
5	007013	Expansion tank / radiator connecting hose - Replacement	
6	007003	Delivery line and coolant return - Replacement	
7	001170	Air deflector - Replacement	

Rear shock-absorber

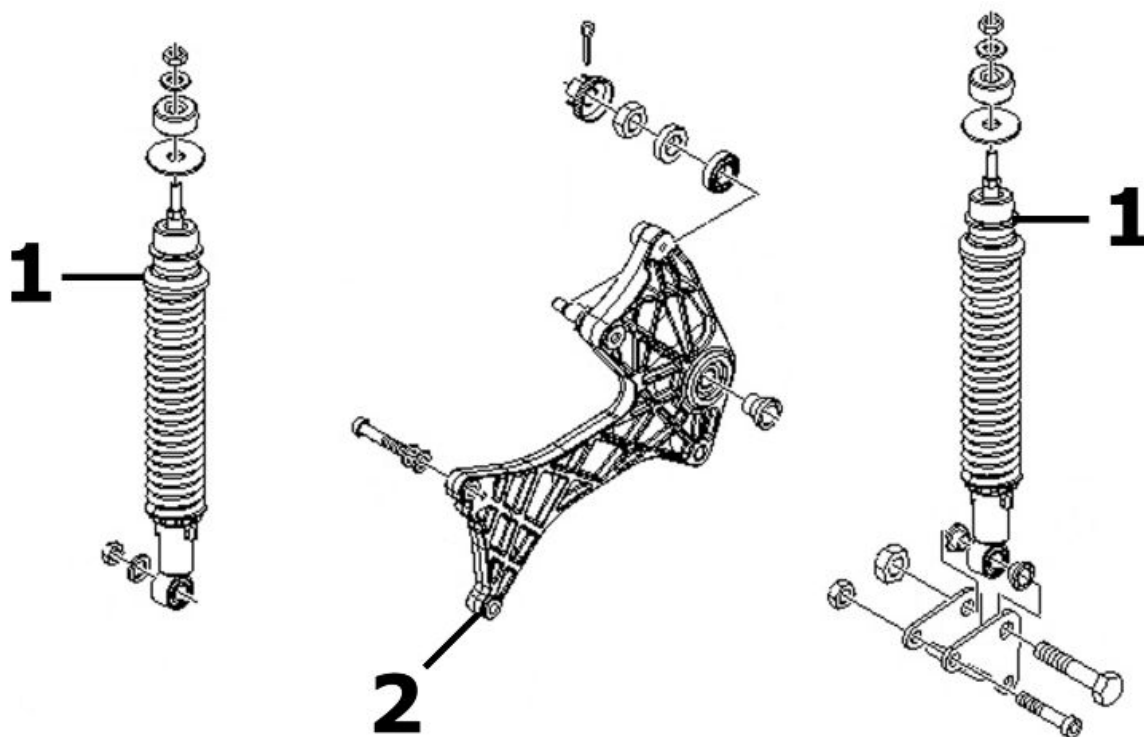

REAR SHOCK ABSORBERS

	Code	Action	Duration
1	003007	Rear shock absorber - Removal and Refitting	
2	003077	muffler/rear shock absorber support arm - Service	

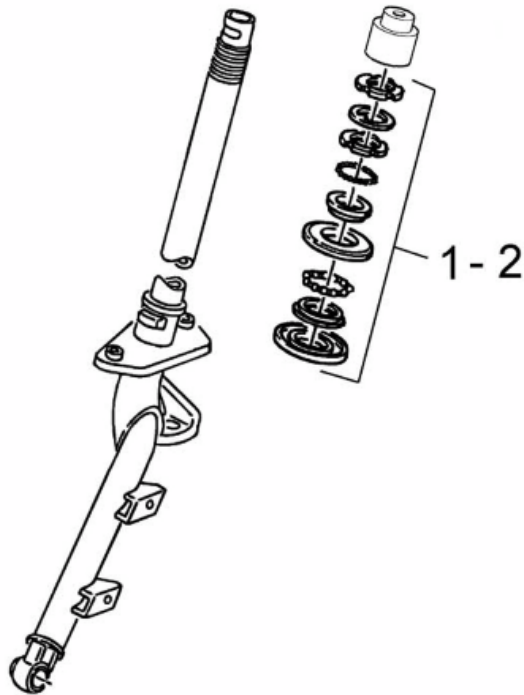
Steering column bearings**STEERING FIFTH WHEELS**

	Code	Action	Duration
1	003002	Steering fifth wheel - Replacement	
2	003073	Steering clearance - Adjustment	

Handlebar covers

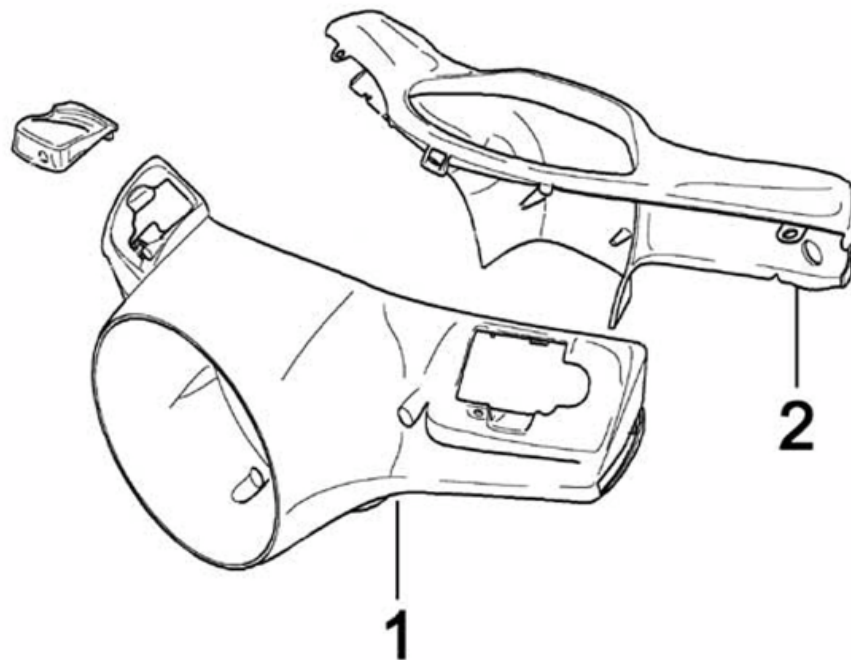

HANDLEBAR COVERS

	Code	Action	Duration
1	004018	Front handlebar covers - Replacement	
2	004019	Rear handlebar cover - Replacement	

Handlebar components

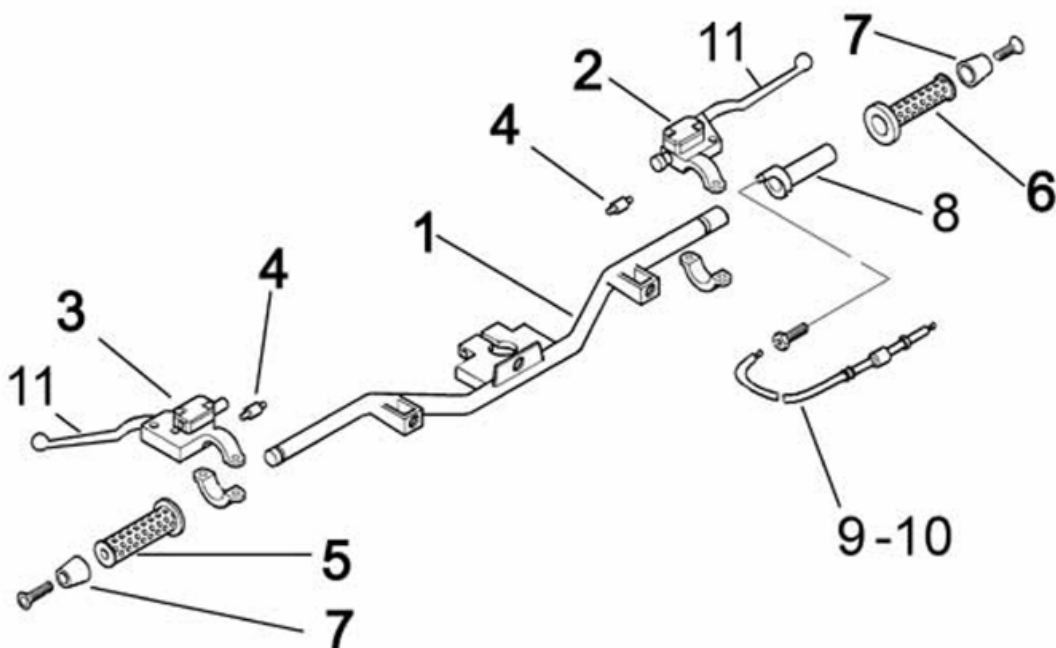

HANDLEBAR COMPONENTS

	Code	Action	Duration
1	003001	Handlebar - Removal and refitting	
2	002067	Rear brake pump - Replacement	
3	002024	Front brake pump - Removal and refitting	
4	005017	Stop switch - Replacement	
5	002059	Right-hand knob - Replacement	
6	002071	Left hand grip - Replacement	
7	003059	Counterweight - Replacement	
8	002060	Throttle grip - Replacement	
9	002063	Throttle control transmission - Replacement	
10	003061	Accelerator transmission - Adjustment	
11	002037	Brake or clutch lever - Replacement	

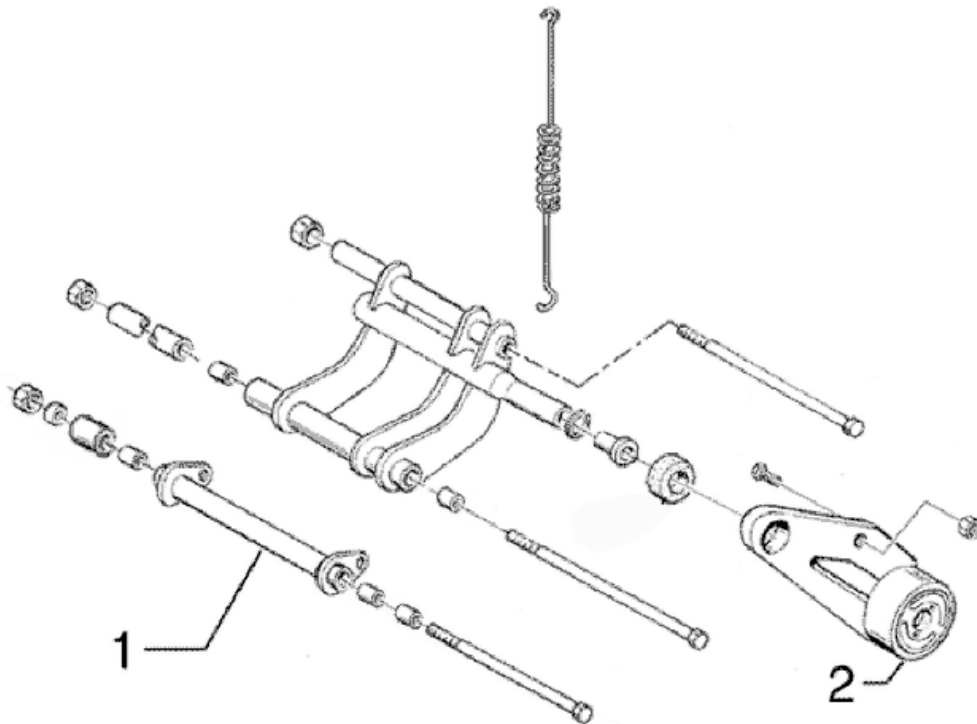
Swing-arm**SWINGING ARM**

	Code	Action	Duration
1	001072	Swinging arm - Engine-chassis connection - Replacement	
2	004058	Silent block - Replacement	

Seat

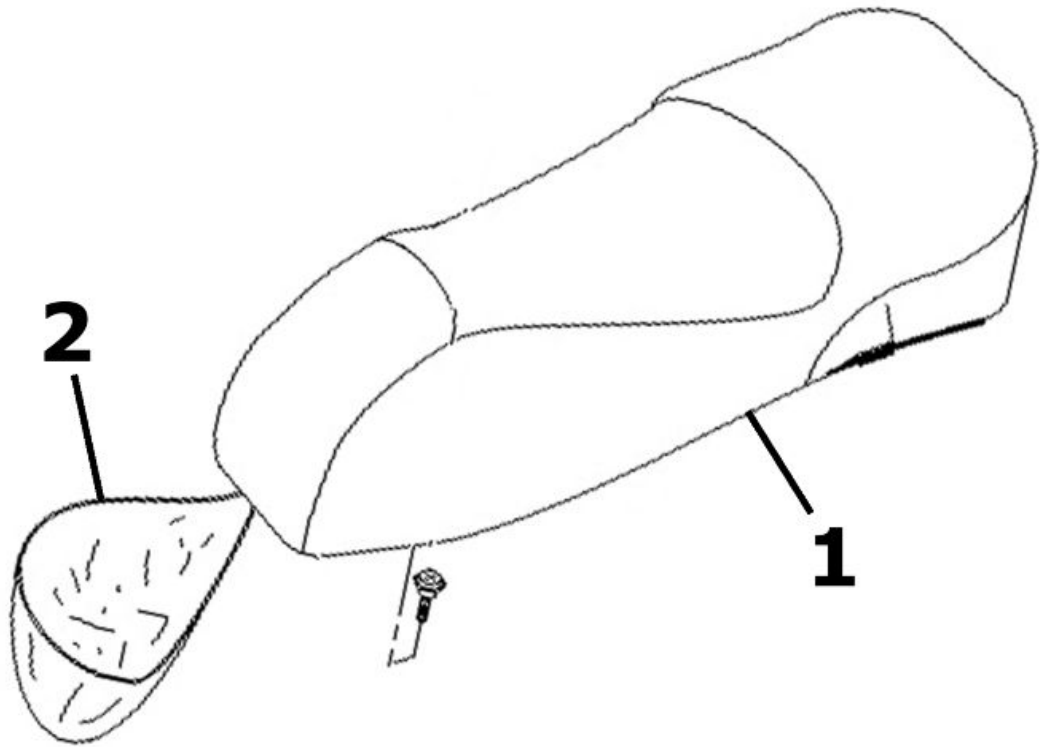

SADDLE

	Code	Action	Duration
1	004003	Saddle - Replacement	
2	004144	Saddle cover - Replacement	

Instrument panel

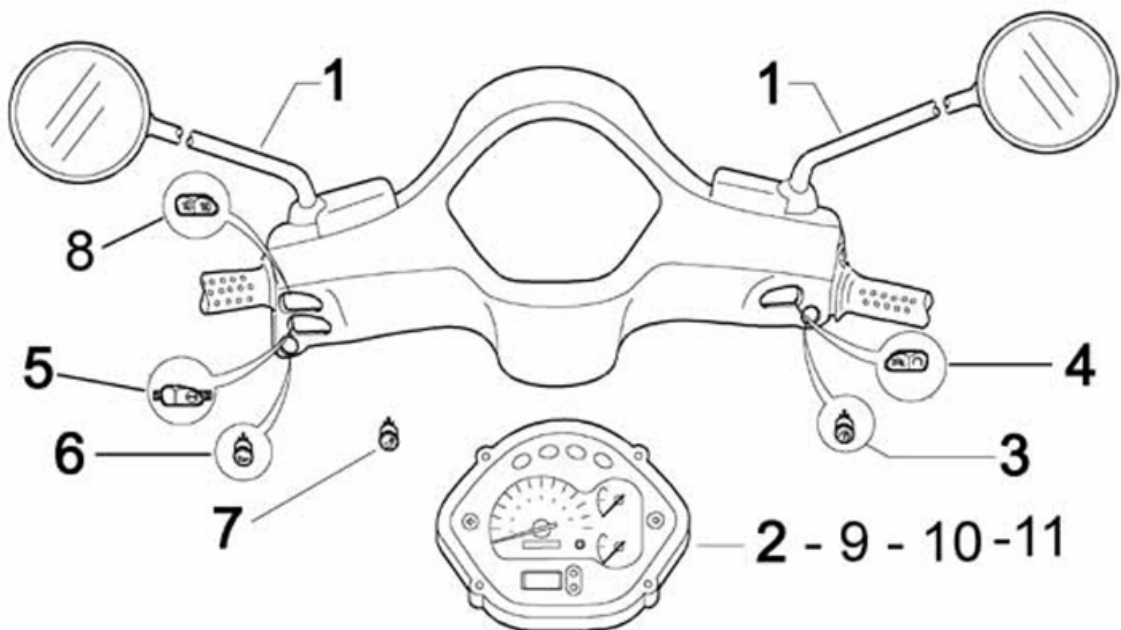

INSTRUMENT PANEL

	Code	Action	Duration
1	004066	Driving mirror - Replacement	
2	005014	Odometer - Replacement	
3	005041	Starter button - Replacement	
4	005077	Emergency stop switch - Replacement	
5	005006	Light switch or turn indicators - Replacement	
6	005040	Horn button - Replacement	
7	005121	Saddle opening button - Replacement	
8	005039	Headlight switch - Replacement	
9	005078	Odometer glass - Replacement	
10	005038	Instrument panel warning light bulbs - Replacement	
11	005076	Clock / Cell - Replacement	

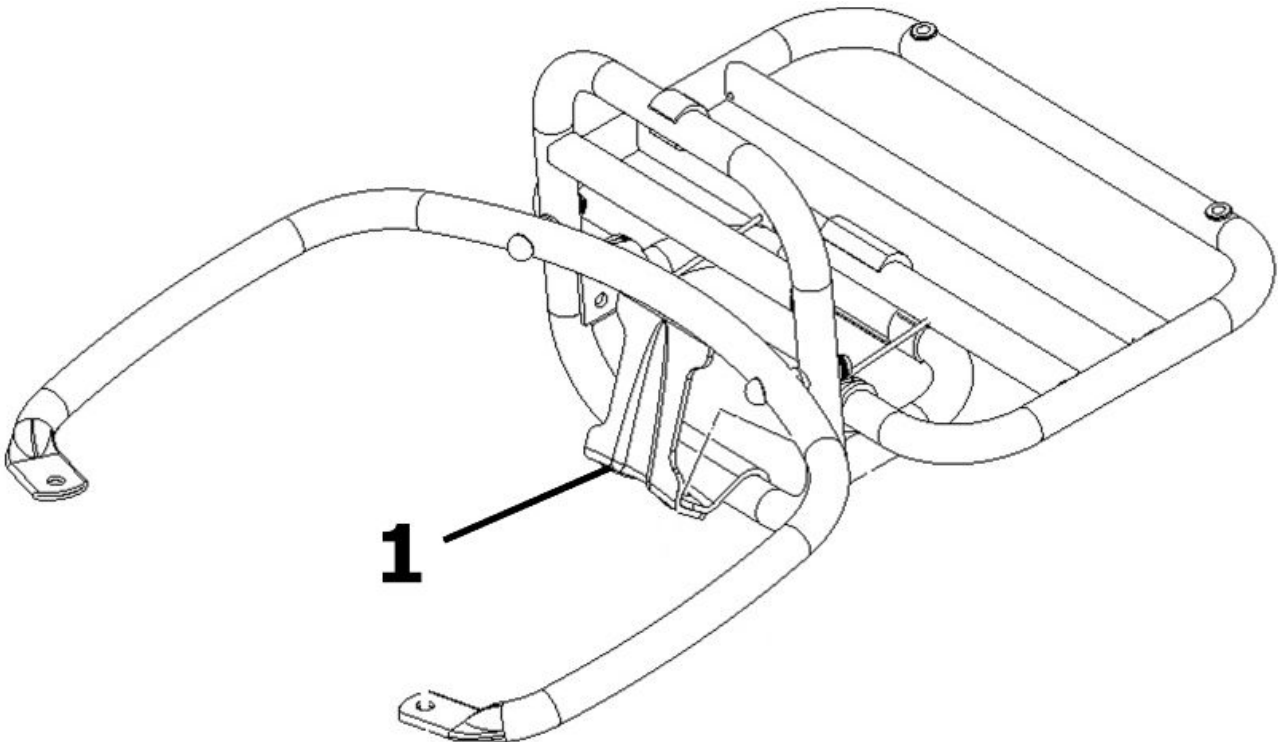
Rear rack**LUGGAGE RACK**

	Code	Action	Duration
1	004008	Luggage rack - Replacement	

Locks

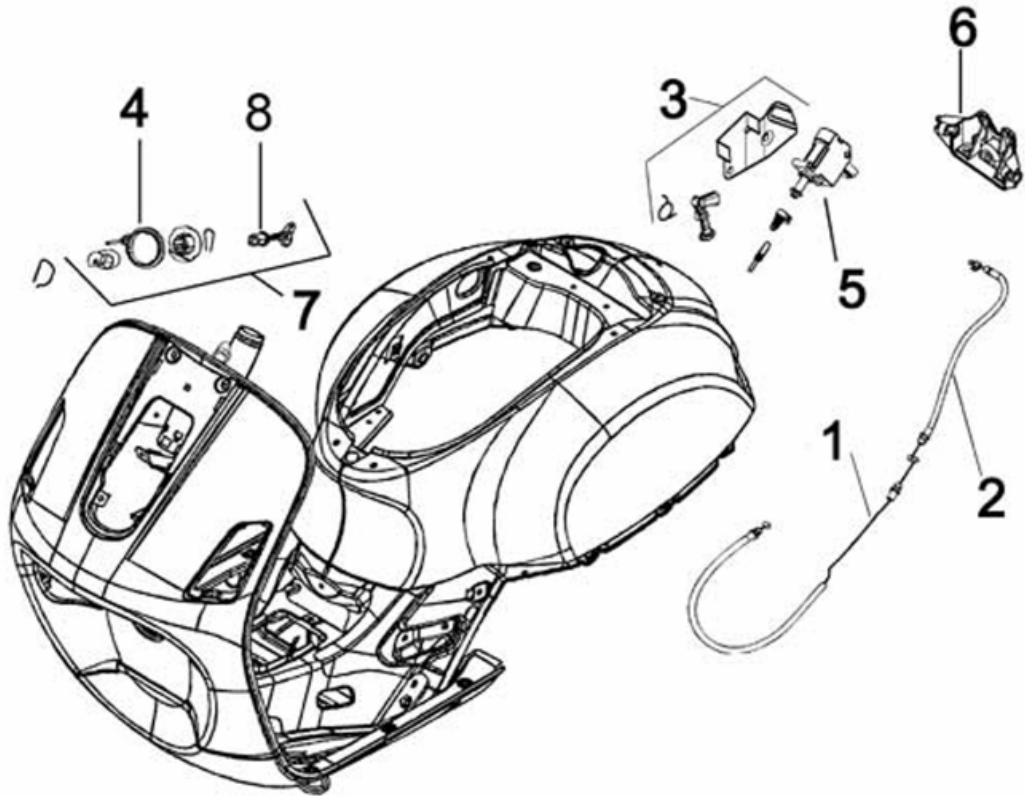

LOCKS

	Code	Action	Duration
1	002083	Saddle opening transmission - Replacement	
2	002092	Transmission splitter/ hook transmission - Replacement	
3	004158	Saddle opening splitter - Replacement	
4	005072	Immobilizer aerial - Replacement	
5	005099	Electric saddle opening device - Replacement	
6	004054	Saddle lock catch - Replacement	
7	004010	Anti-theft lock - Replacement	
8	005016	Key switch - Replacement	

Turn signal lights

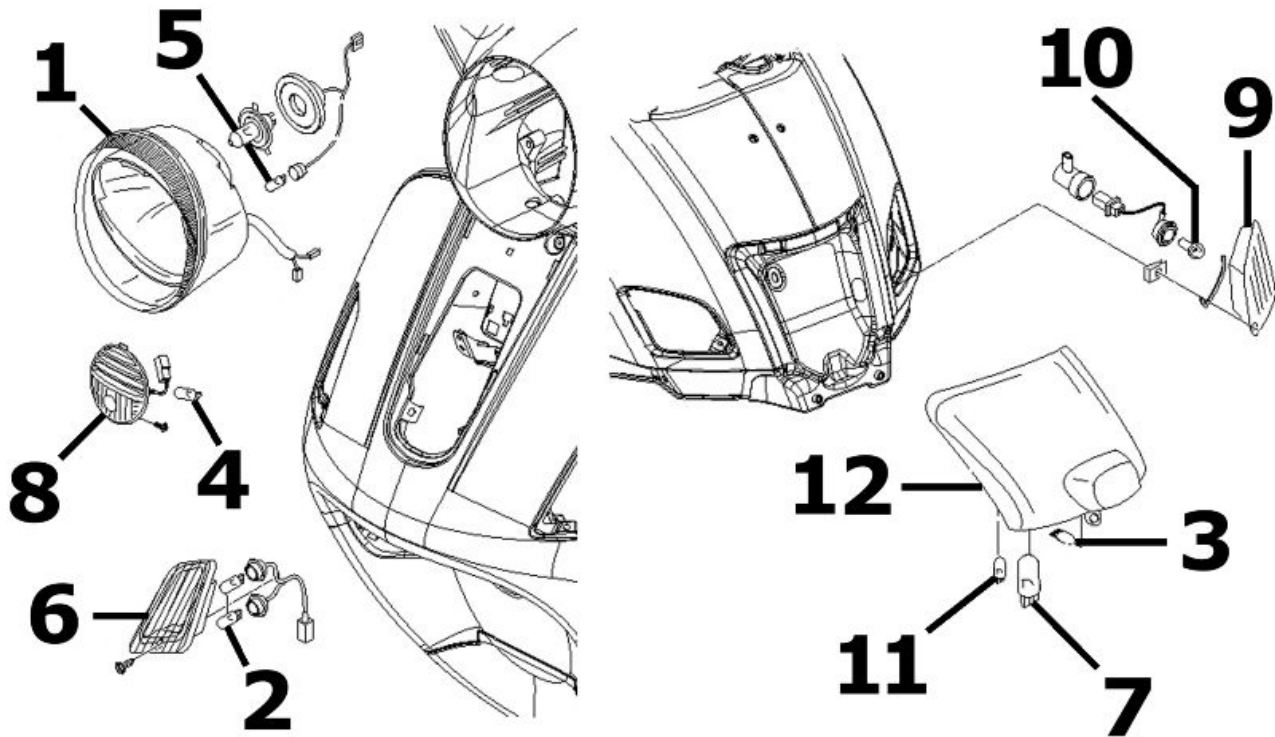
**INDICATORS AND LIGHTS**

	Code	Action	Duration
1	005002	Front headlamp - Replacement	
2	005067	Front turn indicator bulb - Replacement	
3	005031	Licence plate light bulb - Replacement	
4	005139	Tail light bulb - Replacement	
5	005008	Front headlamp bulbs - Replacement	
6	005012	Front turn indicator - Replacement	
7	005090	Stop light bulb - Replacement	
8	005140	Front light - Replacement	
9	005022	Rear turn indicators - Replacement	
10	005068	Rear turn indicator bulb - Replacement	
11	005066	Rear light bulbs - Replacement	
12	005028	Rear light assembly glass - Replacement	

Front wheel

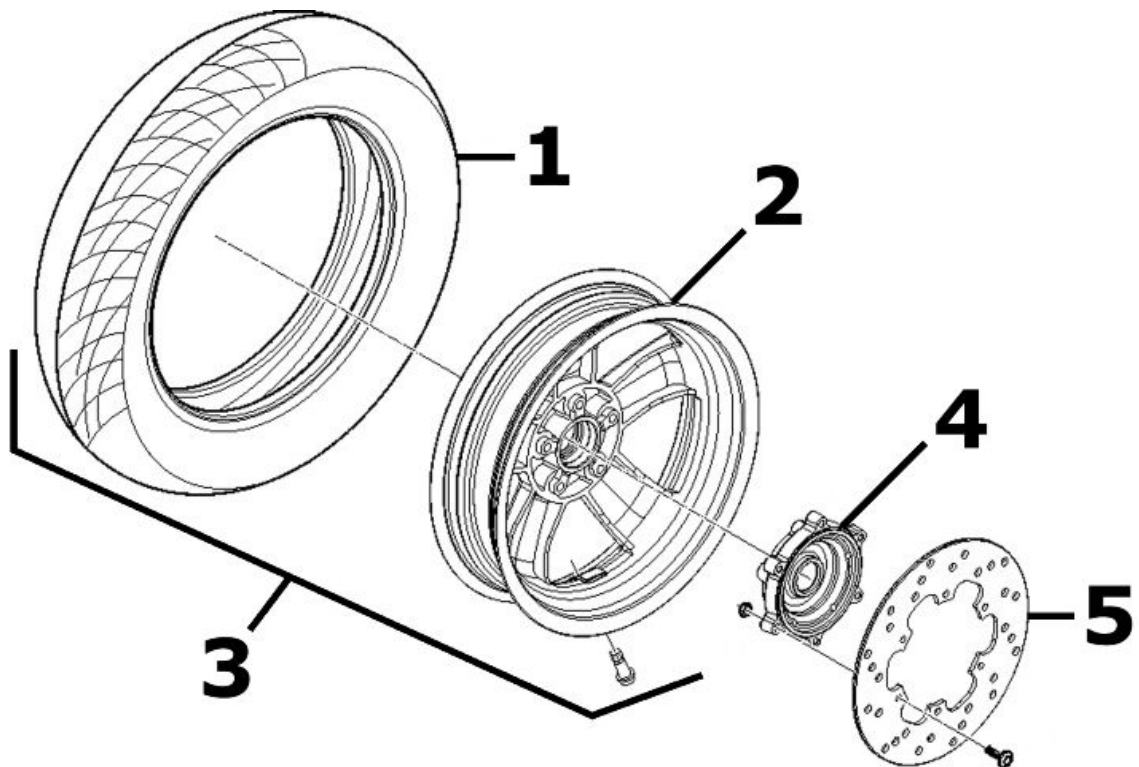

FRONT WHEEL

	Code	Action	Duration
1	003047	Front tyre - replace	
2	003037	Front wheel rim- Replacement	
3	004123	Front wheel - Replacement	
4	003033	Front wheel hub- Replacement	
5	002041	Brake disc - Replacement	

Rear wheel

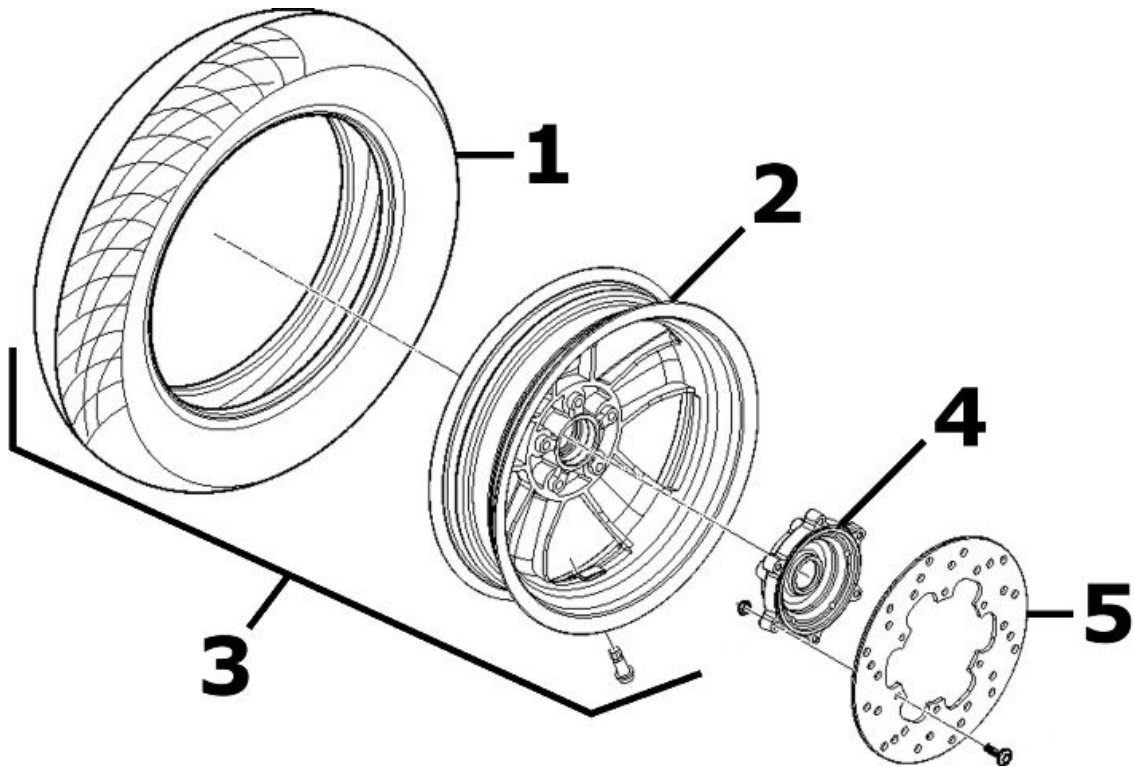
**REAR WHEEL**

	Code	Action	Duration
1	004126	Rear wheel tyre - Replacement	
2	001071	Front wheel rim - Removal and refitting	
3	001016	Rear wheel - Replacement	
4	002028	Rear wheel hub - Replacement	
5	002070	Rear brake disc - Replacement	

Electric devices

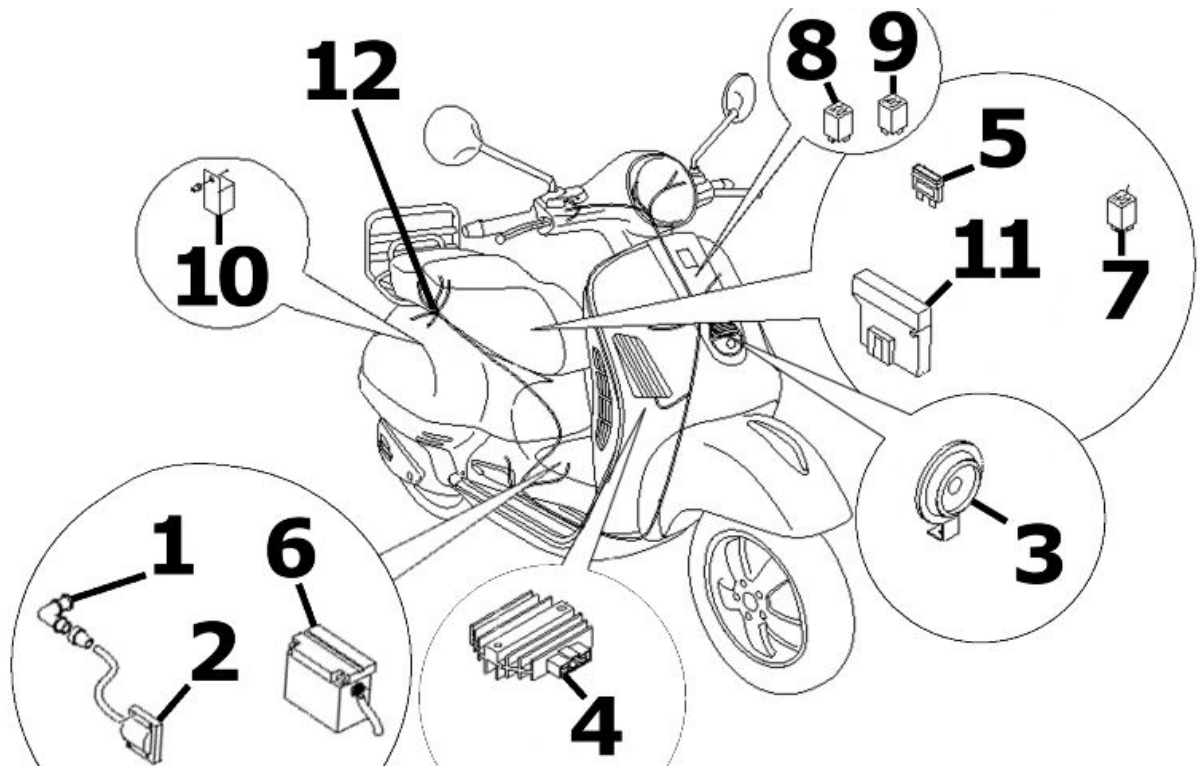

ELECTRICAL DEVICES

	Code	Action	Duration
1	001094	Spark plug cap - Replacement	
2	001069	HV coil - Replacement	
3	005003	Horn - Replacement	
4	005009	Voltage regulator - Replacement	
5	005052	Fuse (1) - Replacement	
6	005007	Battery - Replacement	
7	005120	Control unit power supply remote control - Replacement	
8	005035	Headlight remote control - Replacement	
9	005117	Electric fan remote control - Replacement	
10	005011	Start-up remote control switch - Replacement	
11	005054	Fuse block (1) - Replacement	
12	005001	Electrical system - Removal and re-fitting	

Transmissions

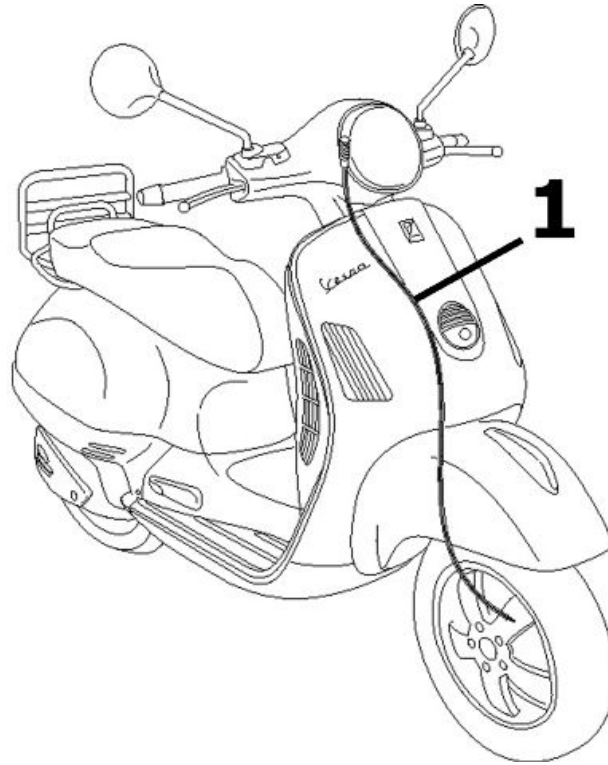

TRANSMISSIONS

	Code	Action	Duration
1	002051	Odometer transmission assembly - Replacement	

Front suspension

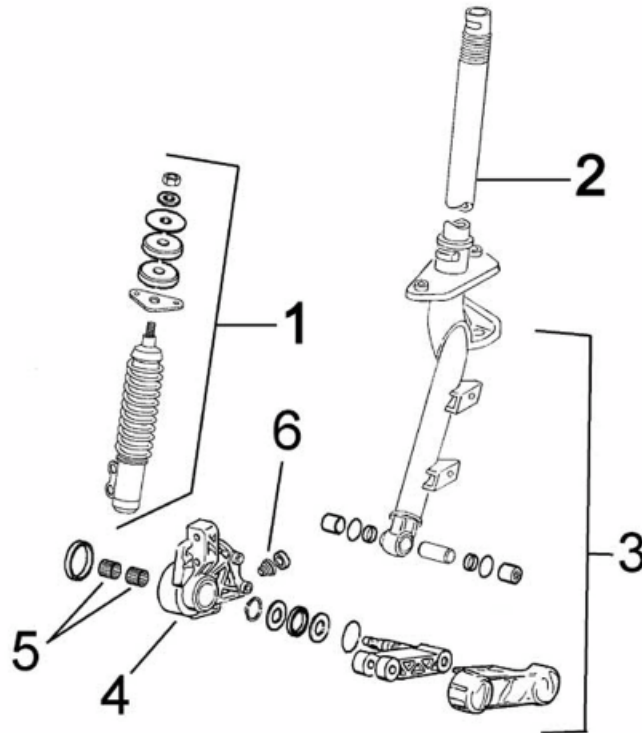

FRONT SUSPENSION

	Code	Action	Duration
1	003011	Front shock absorber - Removal and Refitting	
2	003045	Steering tube - Replacement	
3	003010	Front suspension - Service	
4	003035	Shock absorber support and brake calliper - Replacement	
5	003034	Front wheel hub bearing - Replacement	
6	001064	Odometer reel - Replacement	

Braking system

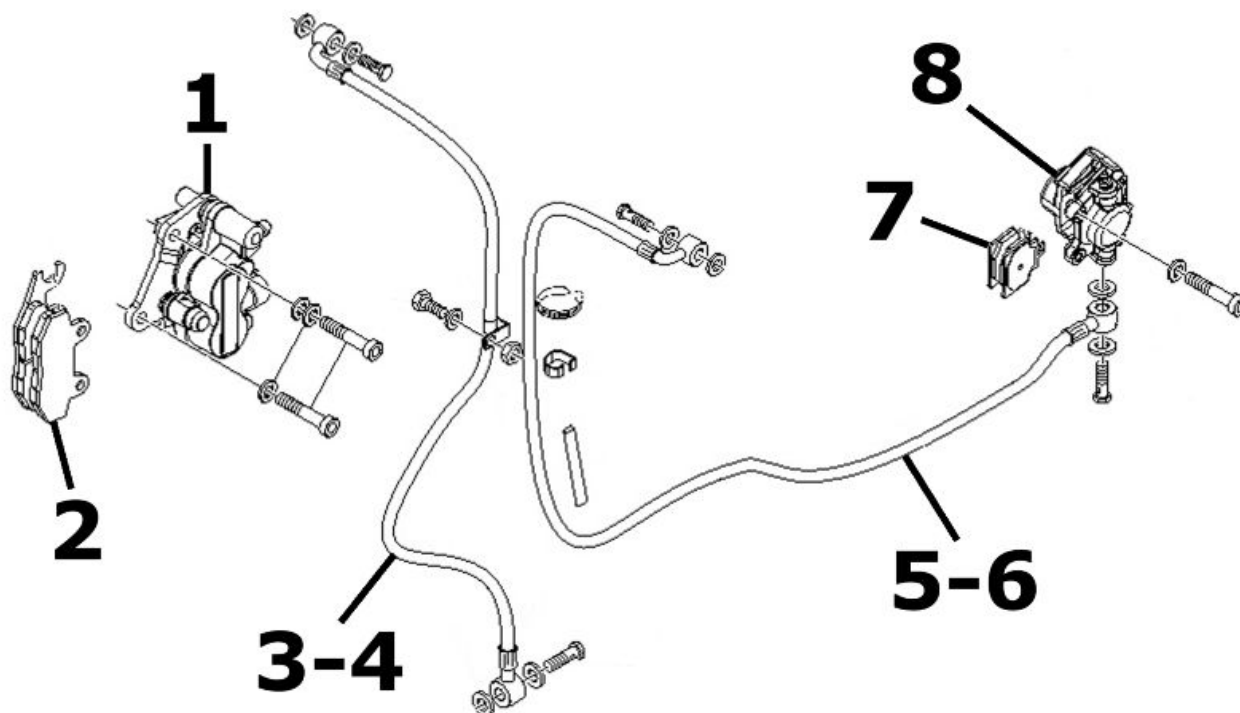
**BRAKE SYSTEM**

	Code	Action	Duration
1	002039	Front brake calliper - Replacement	
2	002007	Front brake pads - Replacement	
3	002021	Front brake piping - Replacement	
4	002047	Front brake fluid and air bleeding system - Replacement	
5	002020	Rear brake disc piping - Replacement	
6	002080	Rear brake oil bleeding system - Replacement	
7	002002	Rear brake pads - Replacement	
8	002048	Rear brake calliper - Replacement	

Stickers

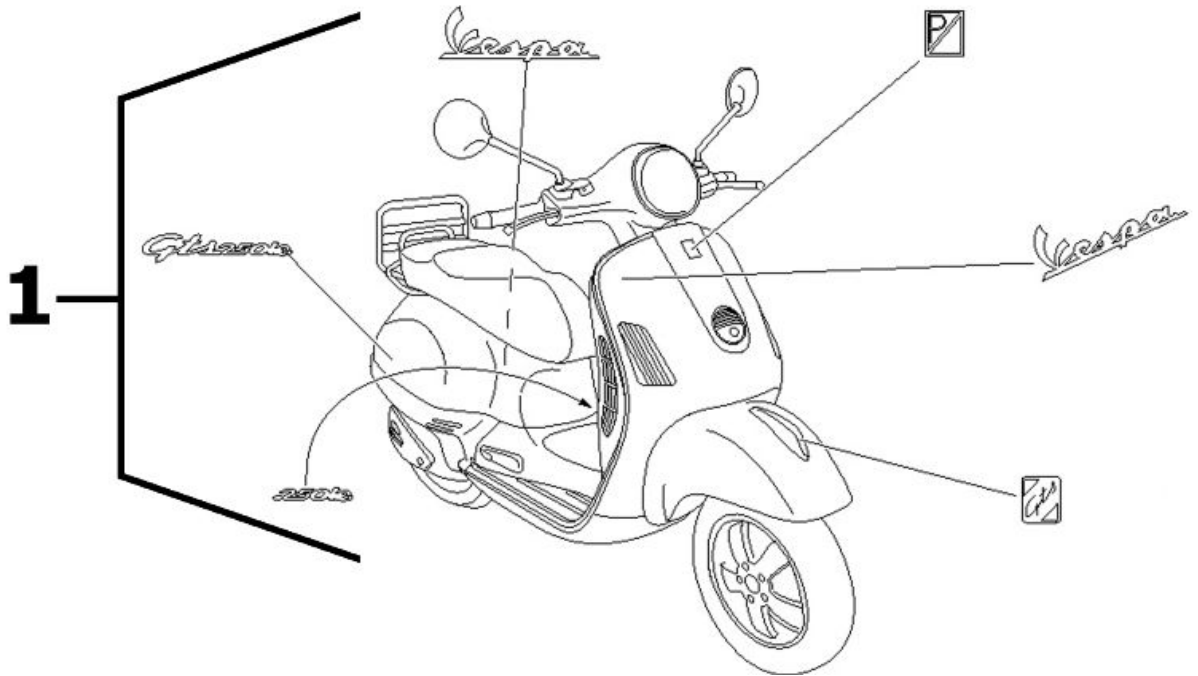

TRANSFERS

	Code	Action	Duration
1	004159	Plates / Stickers - Replacement	

A

Air filter: 49

B

Battery: 80, 90, 99

Brake: 235, 237, 239–241, 243, 245, 246

Brake fluid: 245

C

Coolant: 202

E

Engine oil: 50

F

Fuel: 179, 186, 263, 293

Fuses: 97

H

Headlight: 55, 259

Horn: 93

Hub oil: 48

I

Identification: 8

Instrument panel: 258, 299

L

Light switch:

Luggage rack:

M

Maintenance: 7, 45

O

Oil filter: 51, 277

S

Saddle:

Shock absorbers: 231

Spark plug: 47

Stand: 233

Start-up:

T

Tank: 263, 293

Transmission: 10, 57, 113, 127, 282

Turn indicators: 83

Tyre pressure:

Tyres: 15