

PINOUT PREDISPOSIZIONE PMP

- 1 - + da batteria
- 2 - + da chiave
- 3 - Linea K
- 4 - Luce abbagliante
- 6 - Indicatore di direzione destro
- 7 - CAN L
- 8 - CAN H
- 9 - Tachimetro
- 10 - Massa
- 11 - Indicatore livello carburante
- 12 - Indicatore di direzione sinistro

PMP PREINSTALLATION PINOUT

- 1 - + from battery
- 2 - + from key
- 3 - K line
- 4 - High-beam light
- 6 - Right turn signal
- 7 - CAN L
- 8 - CAN H
- 9 - Speedometer
- 10 - Ground
- 11 - Fuel level indicator
- 12 - Left turn signal

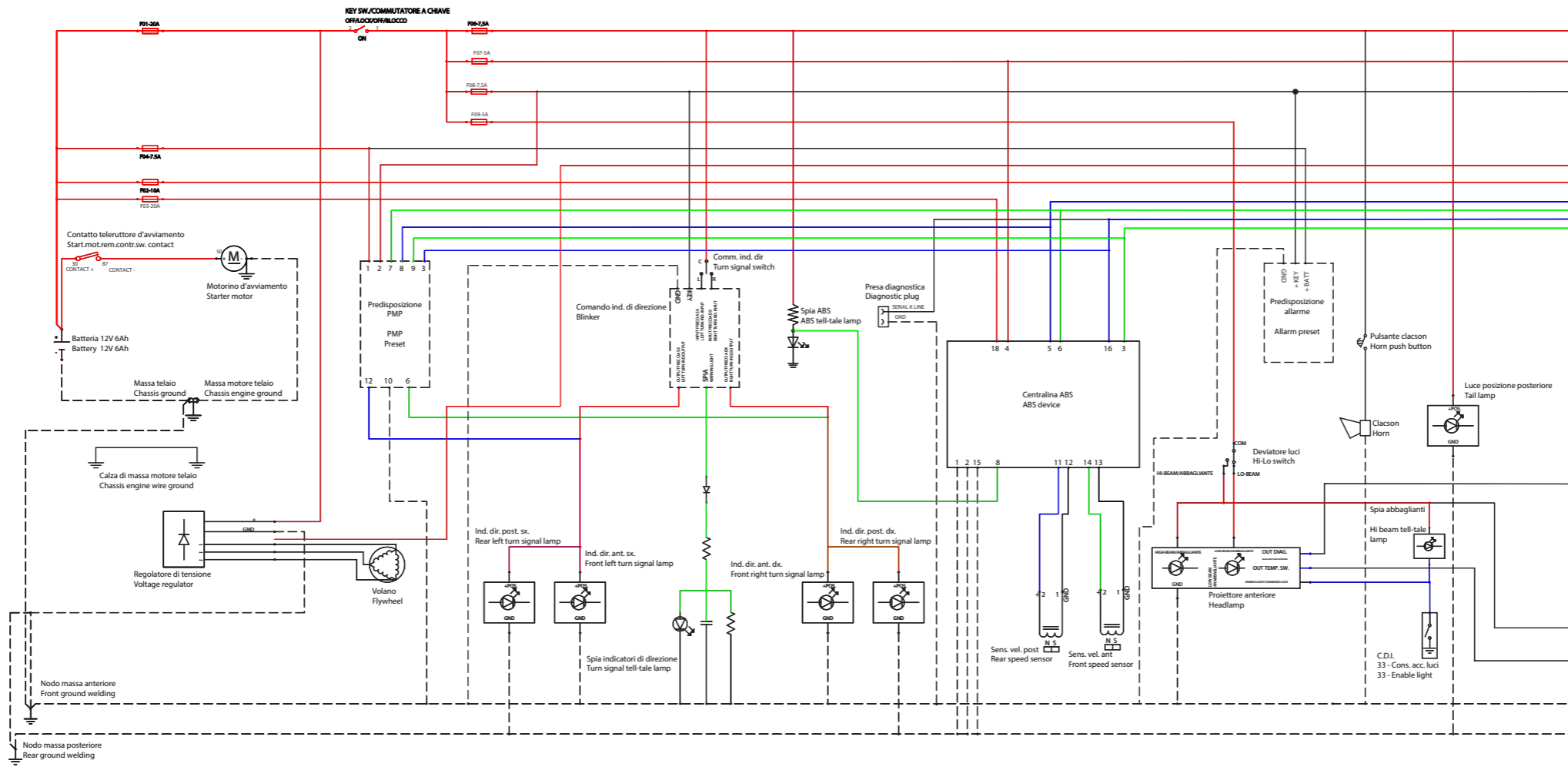

PINOUT CENTRALINA ABS

- 1 - Massa
- 2 - Massa
- 3 - Tachimetro
- 4 - + da chiave
- 5 - CAN H
- 6 - CAN L
- 8 - Spia ABS
- 11 - Segnale ruota fonica posteriore
- 12 - Massa ruota fonica posteriore
- 13 - Massa ruota fonica anteriore
- 14 - Segnale ruota fonica anteriore
- 15 - Massa
- 16 - Linea K
- 18 - + da batteria

ABS CONTROL UNIT PIN-OUT

- 1 - Ground
- 2 - Ground
- 3 - Speedometer
- 4 - + from key
- 5 - CAN H
- 6 - CAN L
- 8 - ABS warning light
- 11 - Rear tone wheel signal
- 12 - Rear tone wheel ground
- 13 - Front tone wheel ground
- 14 - Front tone wheel signal
- 15 - Ground
- 16 - K line
- 18 - + from battery

PINOUT CENTRALINA

- 1 - Bobina A.T.
- 2 - Boost
- 3 - Sensore caduta
- 4 - Interruttore arresto motore
- 5 - Pulsante avviamento motore
- 6 - + da chiave
- 7 - Massa 1
- 8 - Pulsanti STOP
- 9 - + da batteria
- 10 - Consenso all'avviamento
- 11 - Lambda +
- 12 - Lambda -
- 13 - Sensore temperatura motore
- 14 - Antenna immobilizer
- 15 - Massa sensori
- 16 - Linea K
- 17 - Immobilizer
- 18 - Sensore temperatura proiettore
- 19 - Massa sensori
- 20 - Pick up -
- 21 - NC
- 22 - Teleruttore carichi iniezione
- 23 - Massa 2
- 24 - Spia pressione ruote
- 25 - Spia iniezione

CONTROL UNIT PINOUT

- 1 - H.V. coil
- 2 - Boost
- 3 - Fall sensor
- 4 - Engine stop switch
- 5 - Engine start up button
- 6 - + from key
- 7 - Ground lead 1
- 8 - STOP buttons
- 9 - + from battery
- 10 - Start up enabling
- 11 - Lambda +
- 12 - Lambda -
- 13 - Engine temperature sensor
- 14 - Immobilizer antenna
- 15 - Sensor ground
- 16 - K line
- 17 - Immobilizer
- 18 - Headlamp temperature sensor
- 19 - Sensor ground
- 20 - Pick up -
- 21 - NC
- 22 - Injection load solenoid
- 23 - Ground lead 2
- 24 - Tyre pressure warning lamp
- 25 - Injection warning light

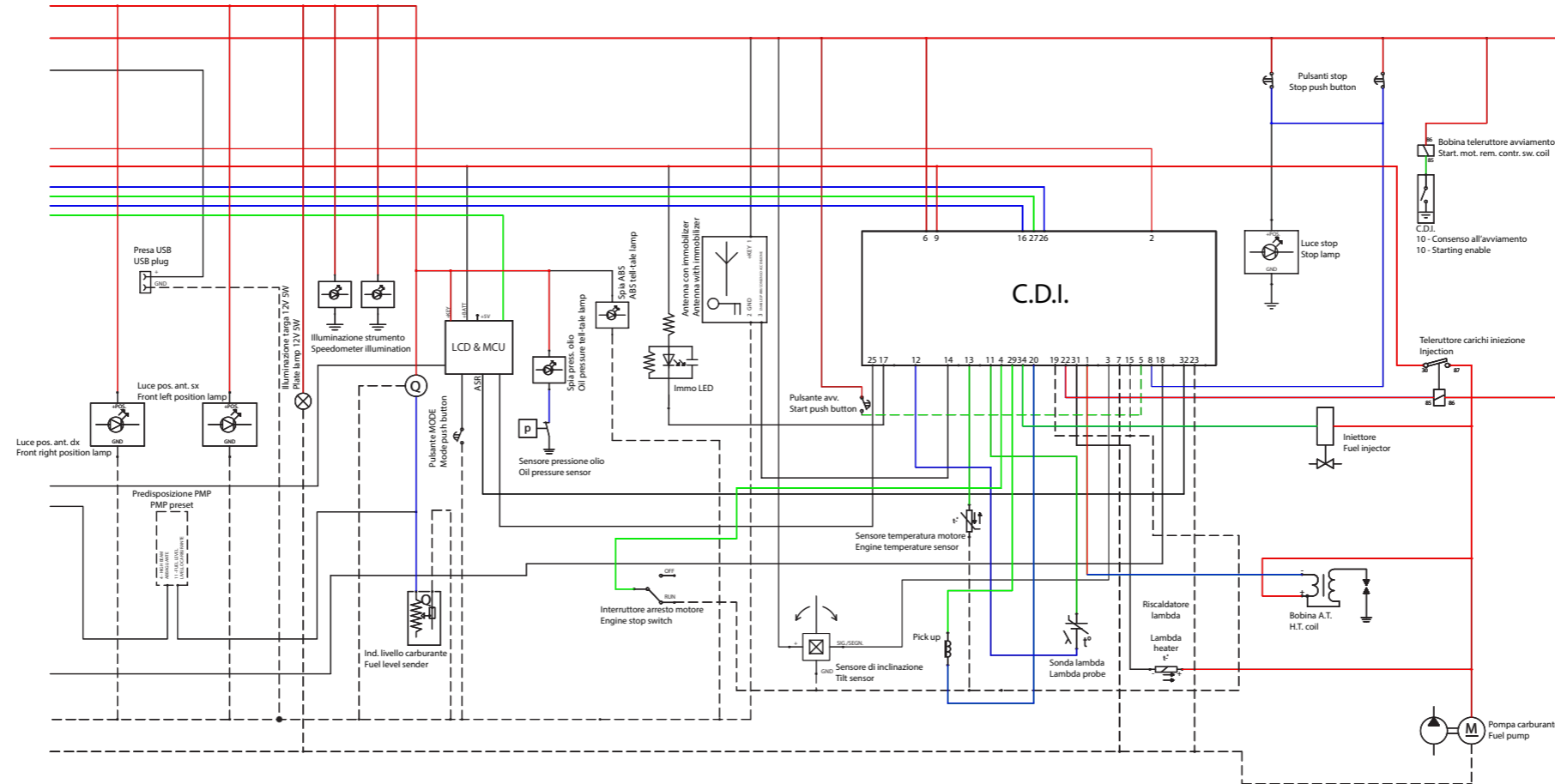

PINOUT CENTRALINA

- 26 - CAN H
- 27 - CAN L
- 28 - NC
- 29 - Pick up +
- 30 - NC
- 31 - Riscaldatore sonda lambda
- 32 - Spia ASR
- 33 - Consenso accensione luci
- 34 - Inietttore

CONTROL UNIT PINOUT

- 26 - CAN H
- 27 - CAN L
- 28 - NC
- 29 - Pick up +
- 30 - NC
- 31 - Lambda probe heater
- 32 - ASR warning light
- 33 - Lights enable
- 34 - Injector

PINOUT PRÉINSTALLATION PMP

- 1 - + par batterie
- 2 - + par clé
- 3 - Ligne K
- 4 - Feu de route
- 6 - Clignotant droit
- 7 - CAN L
- 8 - CAN H
- 9 - Compteur de vitesse
- 10 - Masse
- 11 - Indicateur niveau de carburant
- 12 - Clignotant gauche

PINOUT VORBEREITUNG PMP

- 1 - + von Batterie
- 2 - + über Zündschlüssel
- 3 - Linie K
- 4 - Fernlicht
- 6 - Rechter Blinker
- 7 - CAN L
- 8 - CAN H
- 9 - Tachometer
- 10 - Masse
- 11 - Benzinstandanzeiger
- 12 - Linker Blinker

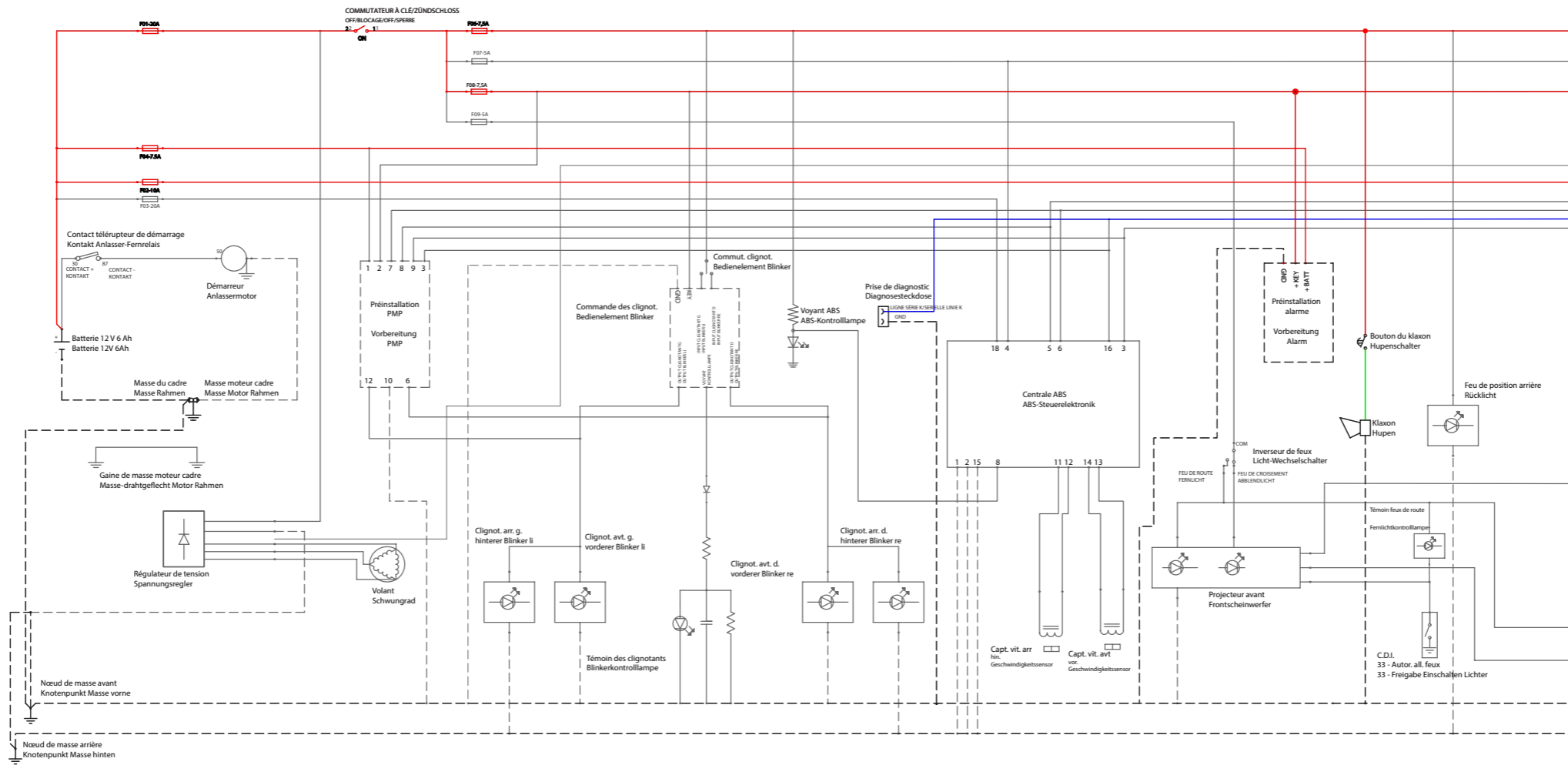

SORTIE CENTRALE ABS

- 1 - Masse
 - 2 - Masse
 - 3 - Compteur de vitesse
 - 4 - + par clé
 - 5 - CAN H
 - 6 - CAN L
 - 8 - Voyant ABS
 - 11 - Signal roue phonique arrière
 - 12 - Masse roue phonique arrière
 - 13 - Masse roue phonique avant
 - 14 - Signal roue phonique avant
 - 15 - Masse
 - 16 - Ligne K
 - 18 - + par batterie
- ### PINOUT ABS-STEUERELEKTRONIK
- 1 - Masse
 - 2 - Masse
 - 3 - Tachometer
 - 4 - + über Zündschlüssel
 - 5 - CAN H
 - 6 - CAN L
 - 8 - ABS-Kontrolllampe
 - 11 - Signal hinterer Hallgeber
 - 12 - Masse hinterer Hallgeber
 - 13 - Masse vorderer Hallgeber
 - 14 - Signal vorderer Hallgeber
 - 15 - Masse
 - 16 - Linie K
 - 18 - + von Batterie

PINOUT CENTRALE

- 1 - Bobine H.T.
- 2 - Boost
- 3 - Capteur de chute
- 4 - Interrupteur arrêt moteur
- 5 - Bouton de démarrage
- 6 - + par clé
- 7 - Masse 1
- 8 - Boutons STOP
- 9 - + par batterie
- 10 - Autorisation au démarrage
- 11 - Lambda +
- 12 - Lambda -
- 13 - Capteur de température moteur
- 14 - Antenne antidémarrage
- 15 - Masse des capteurs
- 16 - Ligne K
- 17 - Antidémarrage
- 18 - Capteur de température projecteur
- 19 - Masse des capteurs
- 20 - Pick up -
- 21 - NF
- 22 - Télérupteur charge d'injection
- 23 - Masse 2
- 24 - Voyant de pression roues
- 25 - Voyant injection

PIN-OUT ZÜNDELEKTRONIK

- 1 - Zündspule
- 2 - Boost
- 3 - Fallsensor
- 4 - Schalter zum Abstellen des Motors
- 5 - Schalter zum Anlassen des Motors
- 6 - + über Zündschlüssel
- 7 - Masse 1
- 8 - Bremslichtschalter
- 9 - + von Batterie
- 10 - Startfreigabe
- 11 - Lambda +
- 12 - Lambda -
- 13 - Motor-Temperatursensor
- 14 - Antenne Wegfahrsperr
- 15 - Masse Sensoren
- 16 - Linie K
- 17 - Wegfahrsperr
- 18 - Temperatursensor Scheinwerfer
- 19 - Masse Sensoren
- 20 - Pick up -
- 21 - NC
- 22 - Fernrelais Einspritz-Ladung
- 23 - Masse 2
- 24 - Reifendruckkontrolllampe
- 25 - Einspritzkontrolllampe

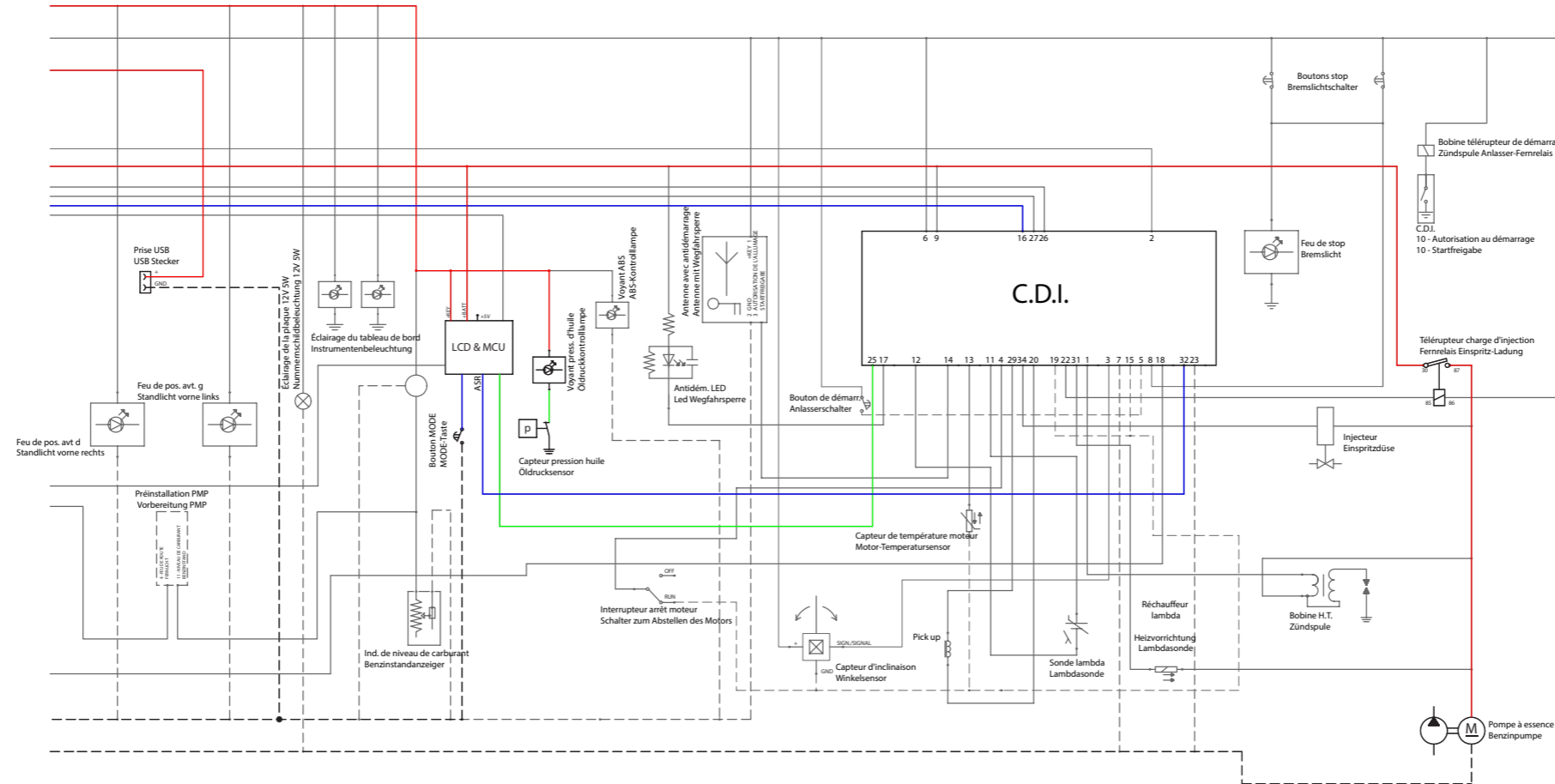

PINOUT CENTRALE

- 26 - CAN H
- 27 - CAN L
- 28 - NF
- 29 - Pick up +
- 30 - NF
- 31 - Réchauffeur sonde lambda
- 32 - Voyant ASR
- 33 - Autorisation allumage feux
- 34 - Injecteur

PIN-OUT ZÜNDELEKTRONIK

- 26 - CAN H
- 27 - CAN L
- 28 - NC
- 29 - Pick up +
- 30 - NC
- 31 - Heizvorrichtung Lambdasonde
- 32 - Kontrolllampe ASR
- 33 - Startfreigabe Lichter
- 34 - Einspritzdüse

PINOUT PREINSTALACIÓN PMP

- 1 - + desde batería
- 2 - + desde tensión
- 3 - Línea K
- 4 - Luz de carretera
- 6 - Intermitente derecho
- 7 - CAN L
- 8 - CAN H
- 9 - Velocímetro
- 10 - Masa
- 11 - Indicador nivel de combustible
- 12 - Intermitente izquierdo

PMP PREINSTALLATION PINOUT

- 1 - + from battery
- 2 - + from key
- 3 - K line
- 4 - High-beam light
- 6 - Right turn signal
- 7 - CAN L
- 8 - CAN H
- 9 - Speedometer
- 10 - Ground
- 11 - Fuel level indicator
- 12 - Left turn signal

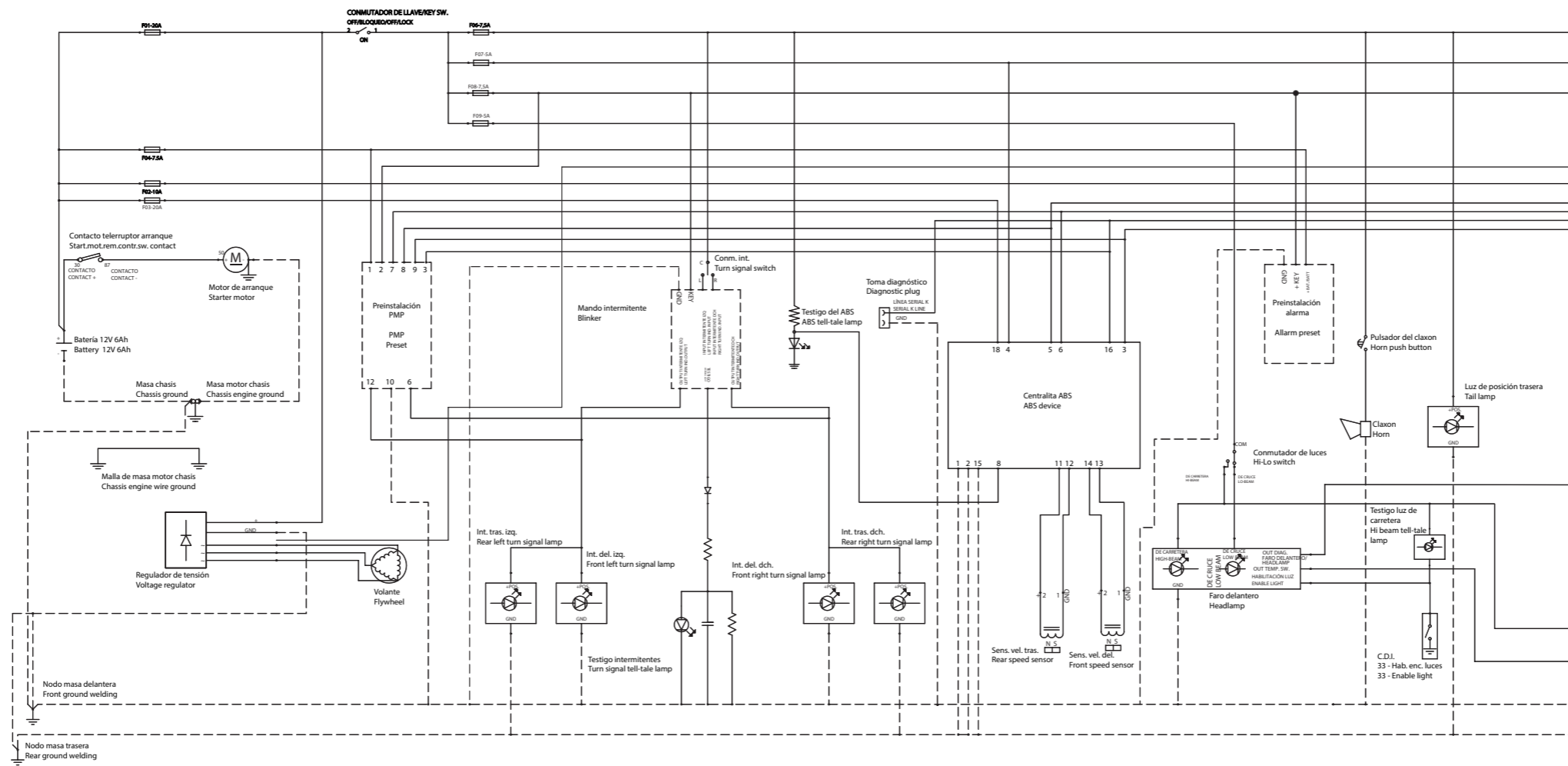

PINOUT CENTRALITA ABS

- 1 - Masa
- 2 - Masa
- 3 - Velocímetro
- 4 - + desde tensión
- 5 - CAN H
- 6 - CAN L
- 8 - Testigo del ABS
- 11 - Señal rueda fónica trasera
- 12 - Masa rueda fónica trasera
- 13 - Masa rueda fónica delantera
- 14 - Señal rueda fónica delantera
- 15 - Masa
- 16 - Línea K
- 18 - + desde batería

ABS CONTROL UNIT PIN-OUT

- 1 - Ground
- 2 - Ground
- 3 - Speedometer
- 4 - + from key
- 5 - CAN H
- 6 - CAN L
- 8 - ABS warning light
- 11 - Rear tone wheel signal
- 12 - Rear tone wheel ground
- 13 - Front tone wheel ground
- 14 - Front tone wheel signal
- 15 - Ground
- 16 - K line
- 18 - + from battery

PINOUT CENTRALITA

- 1 - Bobina A.T.
- 2 - Boost
- 3 - Sensor caída
- 4 - Interruptor parada motor
- 5 - Pulsador de arranque motor
- 6 - + desde tensión
- 7 - Masa 1
- 8 - Pulsadores de STOP
- 9 - + desde batería
- 10 - Habilitación arranque
- 11 - Lambda +
- 12 - Lambda -
- 13 - Sensor de temperatura motor
- 14 - Antena del Immobilizer
- 15 - Masa sensores
- 16 - Línea K
- 17 - Immobilizer
- 18 - Sensor de temperatura faro
- 19 - Masa sensores
- 20 - Pick up -
- 21 - NC
- 22 - Telerruptor cargas inyección
- 23 - Masa 2
- 24 - Testigo presión ruedas
- 25 - Testigo de la inyección

CONTROL UNIT PINOUT

- 1 - H.V. coil
- 2 - Boost
- 3 - Fall sensor
- 4 - Engine stop switch
- 5 - Engine start up button
- 6 - + from key
- 7 - Ground lead 1
- 8 - STOP buttons
- 9 - + from battery
- 10 - Start up enabling
- 11 - Lambda +
- 12 - Lambda -
- 13 - Engine temperature sensor
- 14 - Immobilizer antenna
- 15 - Sensor ground
- 16 - K line
- 17 - Immobilizer
- 18 - Headlamp temperature sensor
- 19 - Sensor ground
- 20 - Pick up -
- 21 - NC
- 22 - Injection load solenoid
- 23 - Ground lead 2
- 24 - Tyre pressure warning lamp
- 25 - Injection warning light

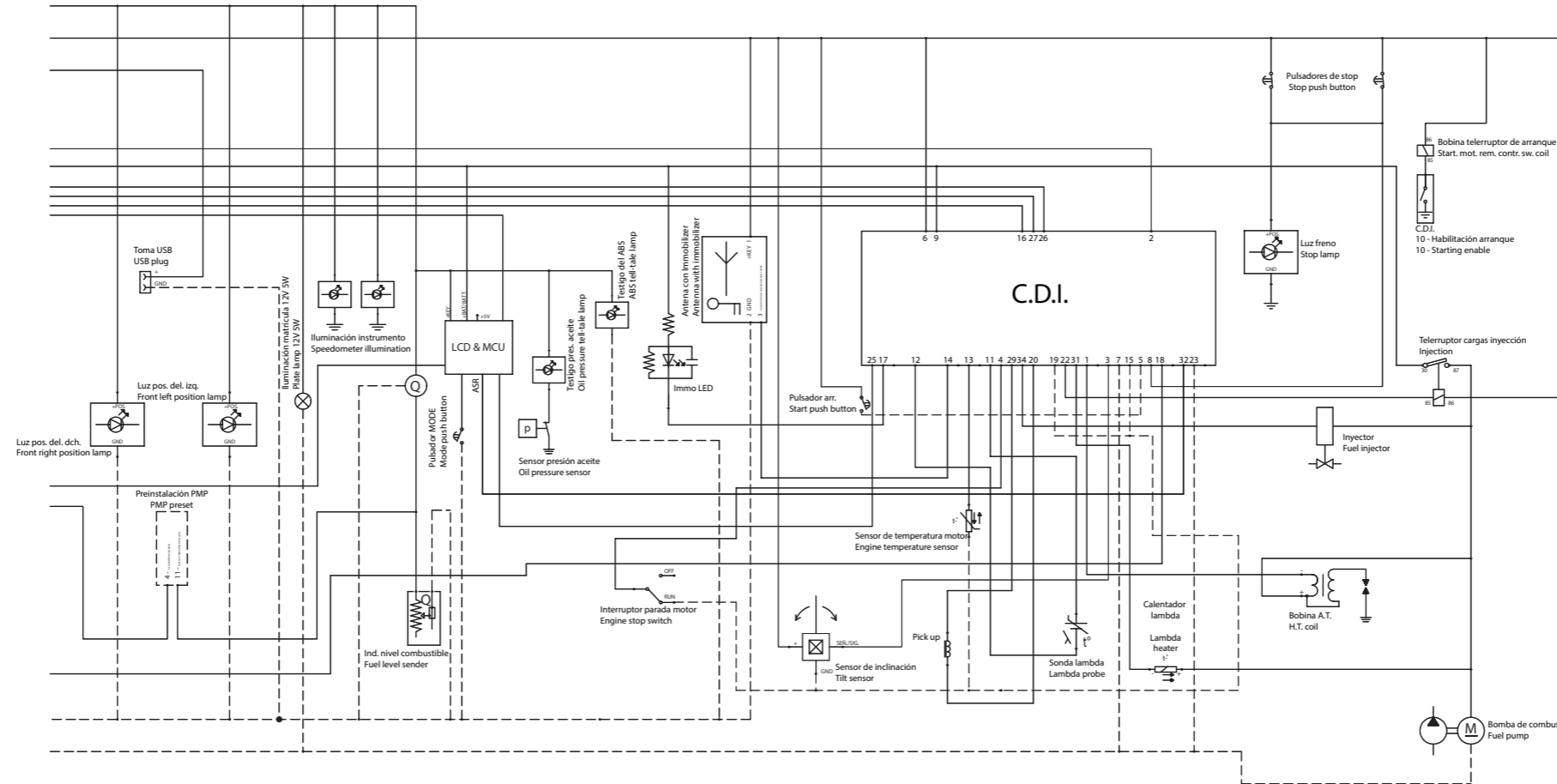

PINOUT CENTRALITA

- 26 - CAN H
- 27 - CAN L
- 28 - NC
- 29 - Pick up +
- 30 - NC
- 31 - Calentador sonda lambda
- 32 - Testigo ASR
- 33 - Habilitación encendido luces
- 34 - Inyector

CONTROL UNIT PINOUT

- 26 - CAN H
- 27 - CAN L
- 28 - NC
- 29 - Pick up +
- 30 - NC
- 31 - Lambda probe heater
- 32 - ASR warning light
- 33 - Lights enable
- 34 - Injector