

PIAGGIO WOULD LIKE TO THANK YOU

for choosing one of its products. We have prepared this booklet to help you to get the very best from your scooter. Please read it carefully before riding the vehicle for the first time. It contains information, tips and precautions for using your vehicle. It also describes features, details and devices to assure you that you have made the right choice. We believe that if you follow our suggestions, you will soon get to know your new vehicle and use it for a long time at full satisfaction. This booklet forms an integral part of the vehicle; should the vehicle be sold, it must be transferred to the new owner.

## **MP3 LT 400 i.e.**



The instructions given in this booklet are intended to provide a clear, simple guide to using your scooter; this booklet also details routine maintenance procedures and regular checks that should be carried out on the vehicle at an **authorised Dealer or Service Centres**. The booklet also contains instructions for simple repairs. Any operations not specifically described in this booklet require the use of special tools and/or particular technical knowledge: to carry out these operations, refer to any **authorised Dealer or Service Centres**.



### **Personal safety**

Failure to completely observe these instructions will result in serious risk of personal injury.



### **Safeguarding the environment**

Sections marked with this symbol indicate the correct use of the vehicle to prevent damaging the environment.



### **Vehicle intactness**

The incomplete or non-observance of these regulations leads to the risk of serious damage to the vehicle and sometimes even the invalidity of the guarantee.

*The signs that you see on this page are very important. They are used to highlight those parts of the booklet that should be read with particular care. As you can see, each sign consists of a different graphic symbol, making it quick and easy to locate the various topics.*



# INDEX

**VEHICLE**..... 7

- Dashboard..... 9
- Analogue instrument panel..... 10
- Clock..... 12
- Digital lcd display..... 13
  - Maintenance icons..... 13
  - \*MODE\* button..... 14
- Key switch..... 14
  - Locking the steering wheel..... 15
  - Releasing the steering wheel..... 15
- Switch direction indicators..... 16
- Horn button..... 16
- Light switch..... 17
- Emergency flashing light button..... 17
- Start-up button..... 18
- Engine stop button..... 18
- Front suspension unlock-lock switch..... 19
- The immobilizer system..... 19
  - Keys..... 19
  - Immobilizerdevice enabled indicator led..... 20
  - Operation..... 21
  - Programming the immobilizer system..... 22
- Saddle opening remote control..... 24
  - Remote control programming..... 24
- Accessing the fuel tank..... 26
- The saddle..... 26
  - Opening the saddle to access the helmet compartment by remote control..... 27
  - Opening the saddle to access the helmet compartment in an emergency..... 29
  - Opening of top box..... 30
  - Identification..... 30

**USE**..... 33

- Checks..... 34
- Refuelling..... 34
- Tyre pressure..... 37
- Shock absorbers adjustment..... 38
- Running in..... 39
- Starting up the engine..... 40
  - Precautions..... 43
- Difficult start up..... 44
- Stopping the engine..... 44
- Stand..... 45
- Automatic transmission..... 45
- Safe driving..... 46
- Front suspension locking system..... 48
- Integral pedal braking system..... 53

**MAINTENANCE**..... 55

- Engine oil level..... 56
  - Engine oil level check..... 56
  - Engine oil top-up..... 57
  - Warning light (insufficient oil pressure)..... 57
  - Engine oil change..... 58
- Hub oil level..... 59
- Tyres..... 61
- Spark plug dismantlement..... 62
- Removing the air filter..... 64
- Air filter cleaning..... 64
- Cooling fluid level..... 65
- Checking the brake oil level..... 66
  - Braking system fluid top up..... 67
- Battery..... 69
  - Use of a new battery..... 69
- Long periods of inactivity..... 70
- Fuses..... 70
- Front light group..... 75

|   |            |
|---|------------|
| Headlight adjustment.....               | 79         |
| Front direction indicators.....         | 79         |
| Rear optical unit.....                  | 80         |
| Rear turn indicators.....               | 82         |
| Number plate light.....                 | 83         |
| Helmet compartment lighting bulb.....   | 83         |
| Rear-view mirrors.....                  | 84         |
| Front and rear disc brake.....          | 84         |
| Puncture.....                           | 85         |
| Periods of inactivity.....              | 86         |
| Cleaning the vehicle.....               | 87         |
| <b>TECHNICAL DATA.....</b>              | <b>91</b>  |
| Kit equipment.....                      | 96         |
| <b>SPARE PARTS AND ACCESSORIES.....</b> | <b>97</b>  |
| Warnings.....                           | 98         |
| <b>PROGRAMMED MAINTENANCE.....</b>      | <b>101</b> |
| Scheduled maintenance table.....        | 102        |

# MP3 LT 400 i.e.



**PIAGGIO®**



**Chap. 01  
Vehicle**

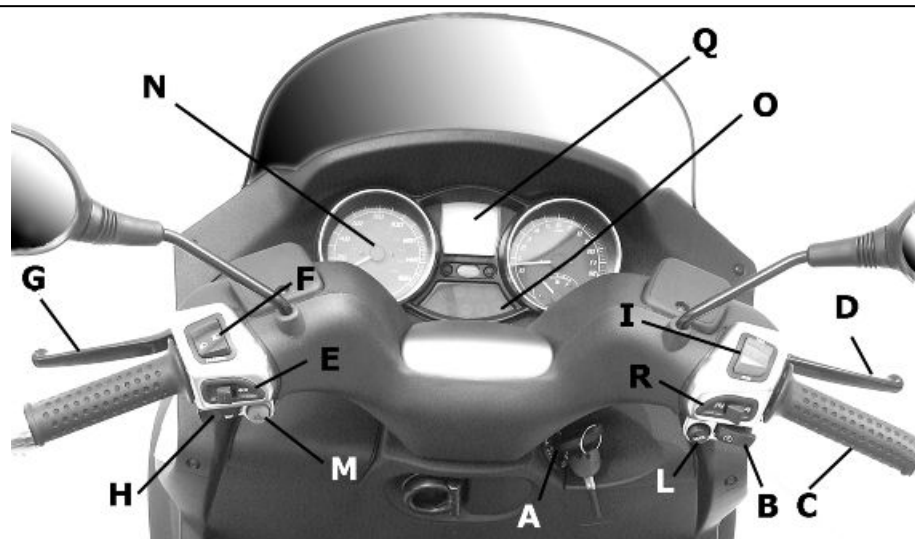

01\_01

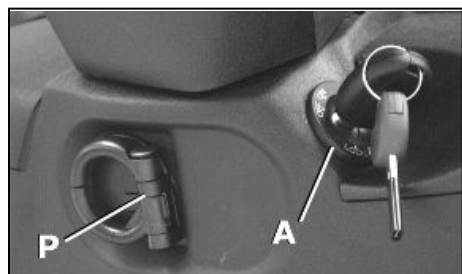

01\_02



## Dashboard (01\_02)

**A** = Ignition key-switch

**B** = Starter button

**C** = Throttle grip

**D** = Front brake lever

**E** = Turn indicator switch

**F** = Headlight switch

**G** = Rear brake lever

**H** = Horn button

**I** = Engine cut-off switch

**L** = Mode switch

**M** = Emergency turn indicator switch

**N** = Analogue instrument panel

**O** = Indicator unit

**P** = Bag hook

**Q** = Digital instrument panel

**R** = Front suspension locking-unlocking switch

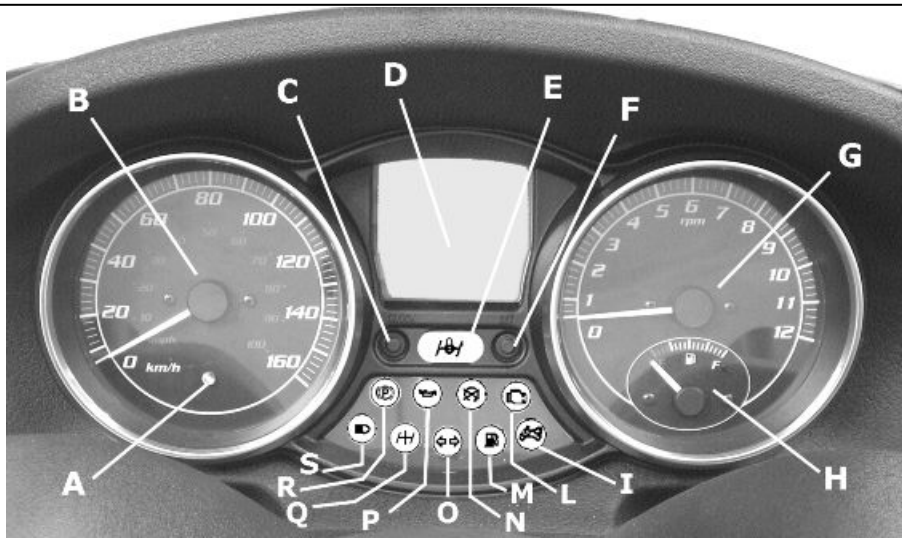

01\_03

### Analogue instrument panel (01\_03)

A = Led immobilizer / anti-theft device

B= Speedometer with twin scale (km/h and mph)

C = CLOCK switch

D = Digital display

E = Front suspension locking system warning light

F = SET switch

G = Rpm indicator

H = Fuel gauge

I = Warning light for helmet compartment courtesy light on

L = Engine control telltale light and injection system failure warning light

M = Low fuel warning light

N = Engine stop warning light

D= Turn indicator warning light

P = Low oil pressure warning light

Q = Front suspension locking system failure warning light

R = Warning light for parking brake engaged

C = High-beam warning light

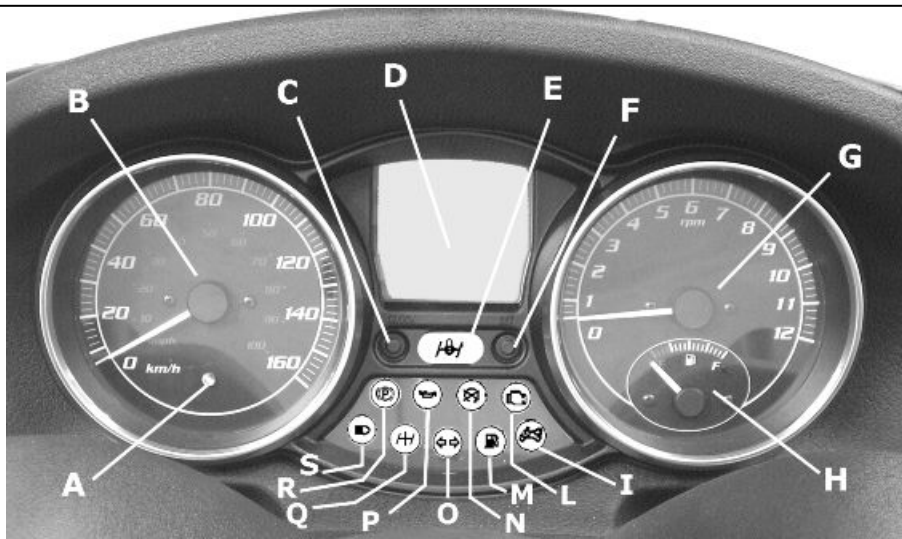

01\_04

### Clock (01\_04)

Pushing the «**CLOCK**» button for less than 1 second displays the following sequence:

- TIME
- DATE

To set the clock, push and hold the «**CLOCK**» button for other 3 seconds.

The numbers showing the hours will begin flashing.

Set the hour using the «**SET**» button. Push the «**CLOCK**» button again and the minutes numbers start flashing.

Set the minutes using the «**SET**» button. Push the «**CLOCK**» button again and the day numbers start flashing.

Set the day with the «**SET**» button. Push the «**CLOCK**» button again and the month numbers start flashing.

Set the month with the «**SET**» button. Push the «**CLOCK**» button again and the year numbers start flashing.

Set the year with the «**SET**» button. Press the «**CLOCK**» button again for 4 seconds to exit the adjustment menu.

During the reset process, not pressing any buttons for a period longer than 8 seconds ends the process automatically and the display shows the modified time.

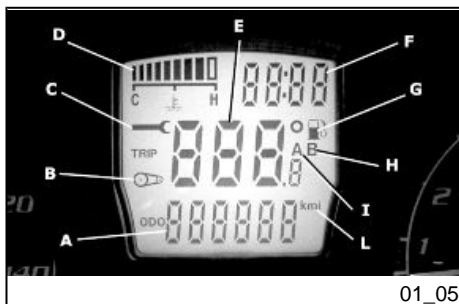

### Digital lcd display (01\_05)

A = Total odometer gauge

B = «**BELT**» maintenance icon

C = «**SERVICE**» maintenance icon

D = Engine coolant temperature indicator

E = Trip odometer (A-B) and ambient temperature gauge (selected with the MODE button)

F = TIME-DATE indicator

G = Low fuel warning light

H = Trip odometer gauge (B)

I = Trip odometer gauge (A)

L = Kilometre - mile indicator

### Maintenance icons

The icons signal the user that scheduled maintenance operations should be carried out. A flashing «**SERVICE**» icon signals the need to carry out the scheduled maintenance.

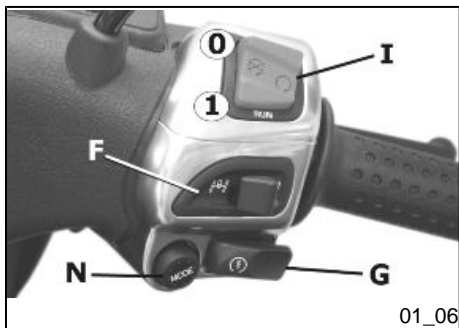

### \*MODE\* button (01\_06)

Pushing the «MODE» switch (N) for less than a second displays the following function sequence:

1. Trip odometer "A"
2. Trip odometer "B"
3. Ambient temperature "°"

Push the «MODE» switch (N) for longer than 3 seconds to zero set the trip odometer

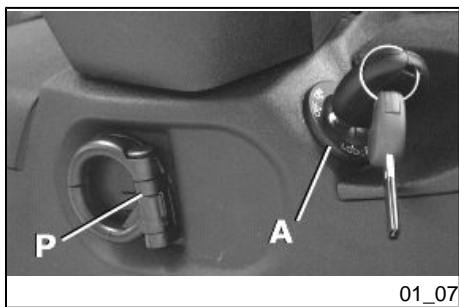

### Key switch (01\_07, 01\_08)

1. **LOCK** = Ignition disabled, extractable key, mechanical antitheft device enabled. The parking brake cannot be released when pressed and cannot be pressed when released.
2. **« OFF »** = Ignition disabled, extractable key, mechanical antitheft device disabled and enabled/disabled parking brake.
3. **ON** = Ready to start, non-extractable key, mechanical antitheft device disabled.
4. **«HELMET COMPARTMENT OPENING»** = Helmet compartment opening position. Press the key when in "OFF" or "ON" and turn it anticlockwise.

nance service. A flashing «BELT» icon signals the driving belt needs replacing. In any case, vehicle maintenance must be carried out at the kilometre service intervals recommended in this booklet.

### WARNING

**REFER TO THE «SCHEDULED MAINTENANCE TABLE» FOR FURTHER MAINTENANCE OPERATIONS**

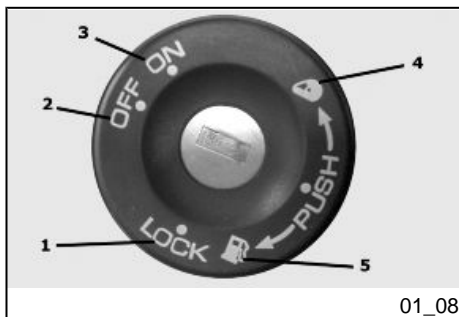

5. «**FUEL TANK COVER OPENING**» = Fuel tank cover opening position. Press the key when in "OFF" or "ON" and turn it clockwise.

### Locking the steering wheel

Turn the handlebar to the left (as far as it will go), turn the key to «**LOCK**» and remove the key.

### Releasing the steering wheel

Reinsert the key and turn it to «**OFF**».

#### CAUTION



**DO NOT TURN THE KEY TO «LOCK» OR «KEY OFF» WHILE RIDING.**

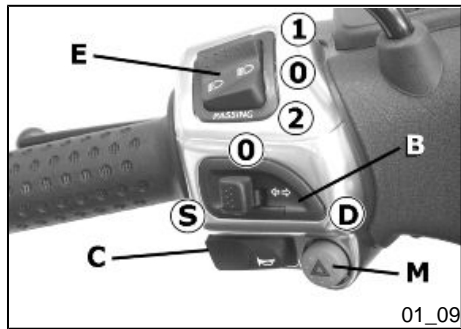

### Switch direction indicators (01\_09)

Lever towards "S" = Left turn indicator is switched on;

Lever towards "D" = Right turn indicator is switched on;

The lever «B» automatically returns to «0» and the turn indicators remain on; press the lever to turn them off.

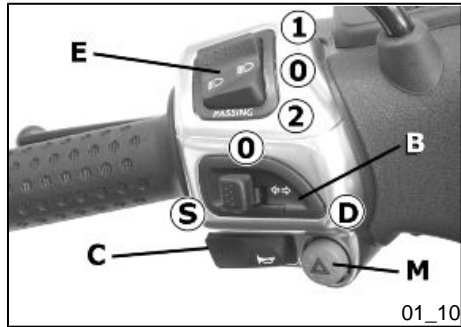

### Horn button (01\_10)

Push the «C» button to sound the horn.



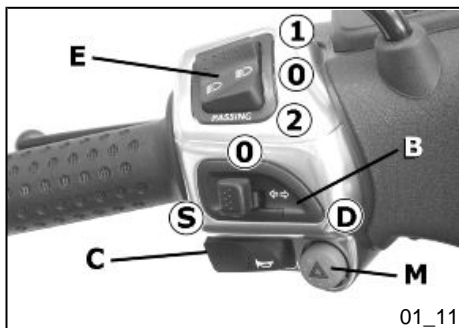

### Light switch (01\_11)

0 = Low-beam light

1 = High beam light

2 = Passing (flashing)

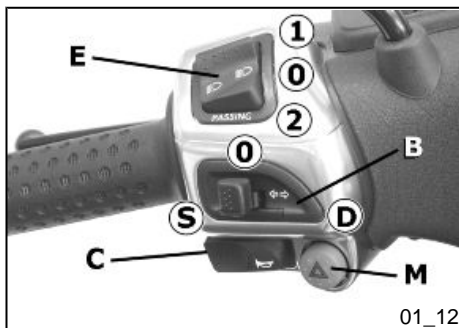

### Emergency flashing light button (01\_12)

It enables the activation of the 4 turn indicators simultaneously. The control «M» can be enabled only with the key set to «ON», but once enabled, it keeps functioning even if the key is set to «OFF» or «LOCK». To disable this function, simply turn the key switch to «ON».



### Start-up button (01\_13)

Turn the key to «ON».

Turn the RUN/OFF switch to «RUN».

Pull one of the two brake levers.

Press the «G» switch to start the engine.

Warning, in vehicles fitted with a suspension locking system, the vehicle will start but will remain at idling speed if the rider is not seated on the saddle in riding position.

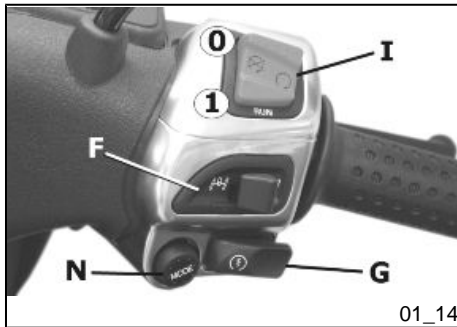

### Engine stop button (01\_14)

Functioning of the engine cut-off switch "I":

0 = OFF

1 = RUN

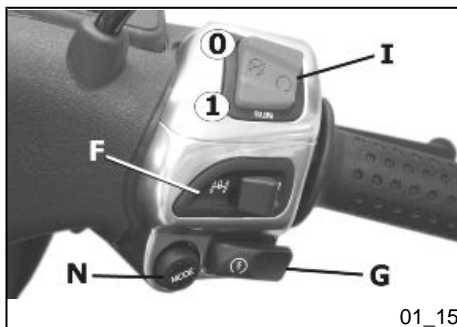

01\_15

## Front suspension unlock-lock switch (01\_15)

The «F» switch engages and disengages the front suspension locking system.

As the topic is so complex, find the instructions for using this control in the **Use** chapter.

## The immobilizer system

In order to enhance theft protection, the vehicle is equipped with a «**PIAGGIO IMMOBILIZER**» electronic engine locking device that is activated automatically when the starter key is removed. Upon start-up, the «**PIAGGIO IMMOBILIZER**» system checks the starter key, and only if this key is recognised will the immobilizer system allow the vehicle to be started.



01\_16

## Keys (01\_16, 01\_17, 01\_18)

Two types of keys are supplied together with the vehicle.

The red handgrip key «A» is the «**MASTER**» key.

Only a single copy of this key is supplied, which is necessary to program all your other keys and for your dealer to perform some maintenance operations. For this reason it is advised that it be used only in exceptional circumstances.

The black key "B" (single copy supplied) is used for normal operations such as:

- engine start up
- open the rear glove-box and the saddle (with remote control)

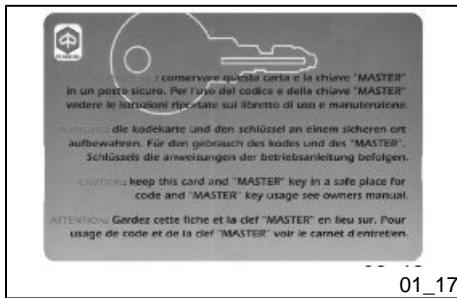

01\_17

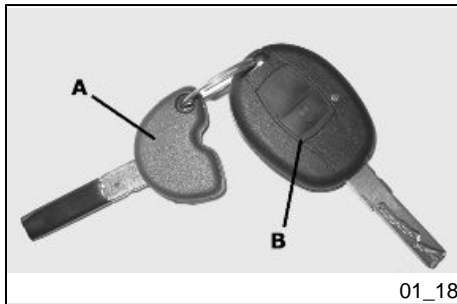

01\_18

Together with the two keys, you will be given a CODE CARD bearing the same code imprinted onto the two keys.

#### WARNING



**LOSING THE RED KEY PREVENTS ANY REPAIRS OF THE 'PIAGGIO IMMOBILIZER' SYSTEM AND THE ENGINE CONTROL UNIT.**

#### WARNING



**KEEP THE 'CODE CARD' AND THE RED HANDGRIP KEY IN A SAFE PLACE (NOT ON YOUR VEHICLE).**

### Immobilizerdevice enabled indicator led (01\_19)

Activation of the "PIAGGIO IMMOBILIZER" system is signalled by a flashing «A» indicator. In order to reduce battery discharge, the indicator LED turns off automatically after 48 hours of uninterrupted functioning. Should the signal led system break down in its flashing function, give information about the type of problem to an **Authorised Piaggio-Gilera Service Centre**.

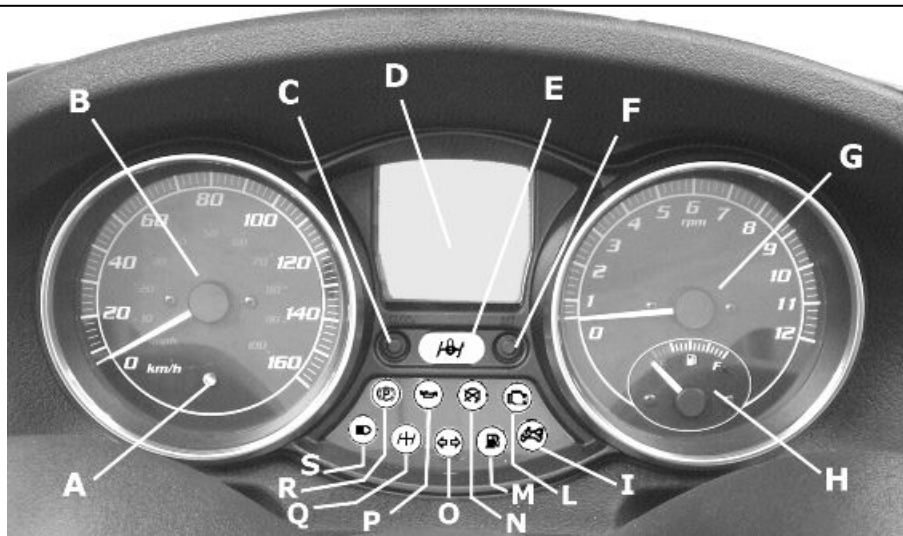

01\_19

## Operation

Every time the starter key is removed in the "OFF" or "LOCK" position, the safety system activates the immobilizer system. Turning the key to "ON" disables the engine lock, provided that the safety system recognises the code transmitted by the key. If the code is not recognised, turn the key first to "OFF" and then to "ON"; if the lock cannot be disabled, try with the other key supplied (red-coloured). If the engine cannot be started, contact an **Authorised Piaggio Service Centre**, which is provided with the electronic equipment required to detect and repair the system.

When additional keys are required, please note that data storage (up to 7 keys max.) must be done on all keys, both new and existing ones.

Take the red handgrip key and all the black keys supplied to an **Authorised Piaggio Service Centre**.

The codes of keys not submitted for the new programming procedure are deleted from the memory. Any lost keys will therefore not be enabled to start the engine.

#### **WARNING**



**EACH KEY HAS ITS OWN AND UNIQUE CODE, WHICH MUST BE STORED IN THE SYSTEM CONTROL UNIT MEMORY.**

**VIOLENT SHOCKS MAY AFFECT THE ELECTRONIC COMPONENTS OF THE KEY.**

**IF OWNERSHIP OF THE VEHICLE IS TRANSFERRED, THE RED HANDGRIP KEY (AS WELL AS THE OTHER KEYS) AND THE "CODE CARD" MUST ALSO BE TRANSFERRED TO THE NEW OWNER.**

### **Programming the immobilizer system**

Below is described the procedure to follow for programming the **PIAGGIO IMMOBILIZER** system and/or for storing other key codes. The programming procedure should be carried out with the engine stop switch set to «**RUN**».

#### **Procedure start - red key**

Insert the red handgrip key in the switch key (in "**OFF**" position) and turn it to "**ON**". After 1 - 3 seconds, turn the key to «**OFF** » again and pull it out.

### Intermediate step - black key

After pulling out the red key, insert the black key within 10 seconds and promptly turn it to «**ON**». After 1-3 seconds, turn the key to «**OFF**» again and pull it out. In this way, a maximum of 7 black keys can be programmed by repeating the above procedure keeping the indicated times.

### Final step - red key

After pulling out the last black key, insert the red key again and turn it to "**ON**" (this operation should be performed within 10 seconds of pulling out the previous key). Leave it in this position for 1 to 3 seconds and return it to «**OFF**».

### Proper programming check

Insert the red key disabling the transponder (i.e., tilt the key cap by 90°) and turn the key to "**ON**". Perform the engine start-up operation. Ensure that the engine does not start. Insert the black key and repeat the start-up operation. Check that engine starts.

#### **WARNING**

**SHOULD THE ENGINE START WITH THE RED KEY (WITH TRANSPONDER OFF), OR IN THE EVENT OF WRONG OPERATION DURING PROGRAMMING, REPEAT THE PROCEDURE FROM THE BEGINNING.**

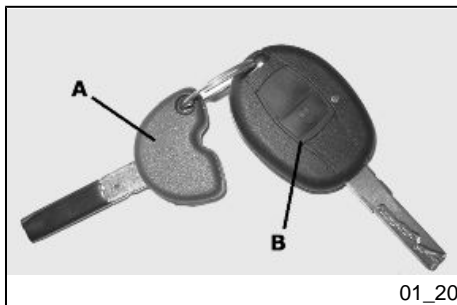

01\_20



01\_21

## Saddle opening remote control (01\_20, 01\_21)

The scooter is fitted with a remote control to open the saddle. This remote control is supplied together with the keys and it has been programmed to control the opening device control unit at the manufacturing stage. If the remote control is lost, a new one can be requested and programmed at any **Authorised Service Centre**. The remote control is powered by internal batteries that get discharged after extended used; If the green LED turns on when the button is pressed, the remote control is working properly. You may need to replace the batteries if the remote control fails or if its range of operation is reduced. To separate the two halves of the remote control, insert the blade of a plain slot screwdriver at one point on the edge and slide it all around. Once the remote control is open, remove the **two batteries** from the contact terminal. Install the two new **CR1616 3V** batteries with the positive pole facing the contact terminal.

Reassemble the remote control by pressing the two clip-on halves gently with your fingers.

To open the saddle without the remote control, follow the procedure described in the «Emergency Saddle Opening» section.

## Remote control programming

Follow these steps to program the remote controls:

1. Insert the remote control key to be programmed in the steering lock key block.
2. Turn the key to «ON», press the button on the remote control, release the button, then turn the key back to «OFF» within four seconds of turning «ON».
3. Wait 1 to 8 seconds.
4. Repeat steps 2 and 3 four more times without removing the key.



The control unit confirms the programming has been successful by opening the saddle.

**WARNING**

**TO STORE THE OTHER REMOTE CONTROLS TO MEMORY (8 MAXIMUM) YOU NEED TO REPEAT THE WHOLE PROCEDURE AGAIN. FAILURE TO CARRY OUT THESE OPERATIONS WITHIN THE INDICATED TIMES WILL RESULT IN THE AUTOMATIC CANCELLATION OF THE PROCESS FOR PROGRAMMING THE REMOTE-CONTROLLED KEYS.**

**WARNING**

**AVOID PRESSING THE REMOTE CONTROL BUTTON MORE THAN ONCE WHEN FAR AWAY FROM THE SCOOTER. THE SYNCHRONISM BETWEEN THE REMOTE CONTROL AND THE RECEIVER CAN BE IMPAIRED. SHOULD THIS BE THE CASE, REPEAT THE PROGRAMMING PROCEDURE. DO NOT KEEP THE REMOTE CONTROL IN PLACES WITH TEMPERATURES EXCEEDING 60° C THE BATTERY WILL RUN DOWN TOO QUICKLY.**

**WARNING**

**TO AVOID BATTERY DISCHARGE, THE SADDLE OPENING REMOTE CONTROL RADIO RECEIVER DEACTIVATES 7 DAYS AFTER THE LAST TIME THE VEHICLE WAS SHUT OFF.**

**JUST TURN THE KEY TO «ON» TO REACTIVATE THE RECEIVER.**

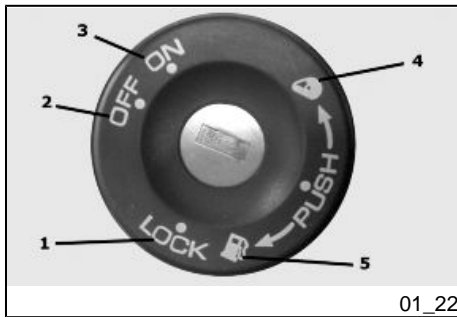

01\_22

### Accessing the fuel tank (01\_22, 01\_23)

To open the fuel tank cover, set the key to «OFF» or « ON», then press and turn it clockwise.

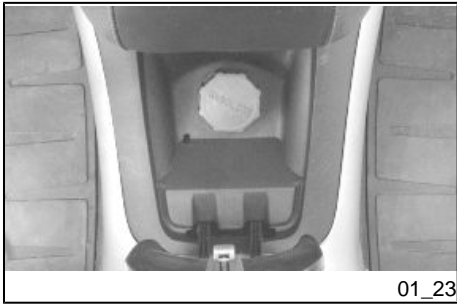

01\_23



01\_24

### The saddle (01\_24, 01\_25, 01\_26)

The saddle is supplied with a protection cover which may be used in case of rain.

Lift the saddle and extract the cover from its housing, then extend it over the whole length of the saddle, starting from the front-end; do not over stretch the cover to avoid tearing the material; close the saddle.



01\_25

**CAUTION****DO NOT USE THE VEHICLE WITHOUT THE PROTECTION COVER.**

01\_26

**Opening the saddle to access the helmet compartment by remote control (01\_27)**

When the key is in «**LOCK**» or «**OFF**» position you can open the saddle using the remote control. The saddle cannot be opened only when the key is set to "ON".

**WARNING****OBJECTS INAPPROPRIATELY ARRANGED INSIDE THE HELMET COMPARTMENT MAY DEFORM THE SADDLE CAUSING THE COURTESY LIGHT TO RE-**

MAIN ON AND THIS WILL DISCHARGE THE BATTERY. IN ANY CASE, THE WARNING LIGHT "I" ON THE INSTRUMENT PANEL SIGNALS IF THE LIGHT IS ON OR OFF.

**WARNING**



THE REMOTE CONTROL OPERATES WITHIN A DISTANCE OF ABOUT 3/5 METRES WITH FULLY CHARGED BATTERIES. WHEN YOU ARE NEAR THE SCOOTER, HANDLE THE REMOTE CONTROL CAREFULLY SO AS TO AVOID UNINTENTIONAL OPENING OF THE SADDLE. REFER TO THE «OPENING THE SADDLE WITH REMOTE CONTROL» SECTION TO REPLACE BATTERIES.

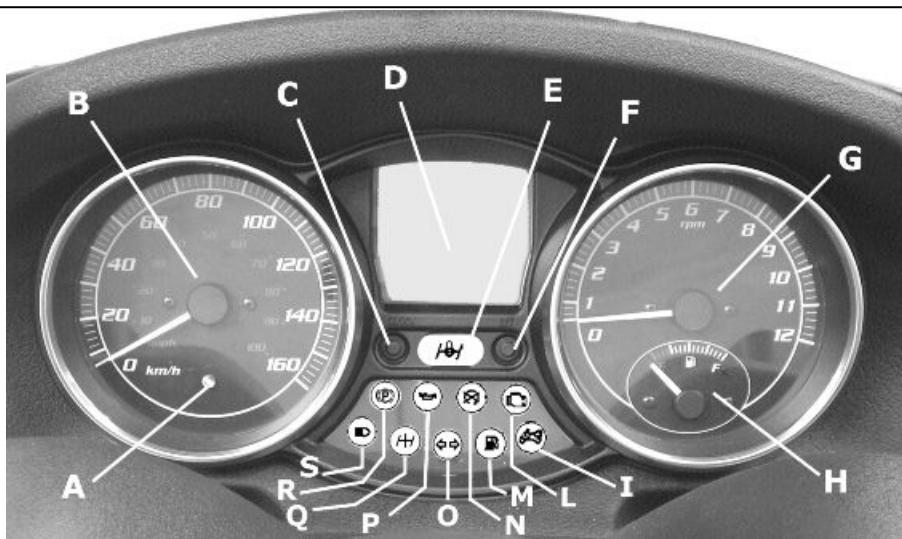

## Opening the saddle to access the helmet compartment in an emergency (01\_28, 01\_29)

If the remote control battery or the vehicle battery is discharged, follow these steps to open the saddle:

1. Open the rear compartment with the key switch
2. Softly press with your hand on the point shown in the photo and in the sense indicated by the arrow inside the helmet compartment until the saddle closing device springs

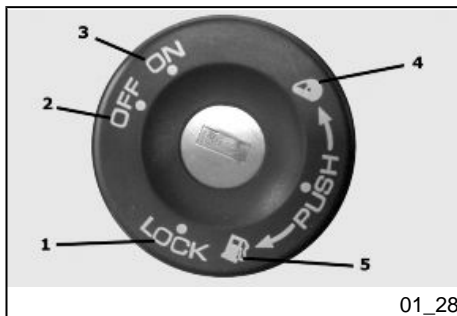

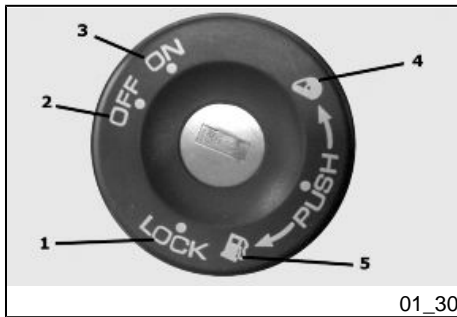

01\_30

## Opening of top box (01\_30)

With the switch set to «OFF» or «ON», press the key and turn it anticlockwise, towards position «4».

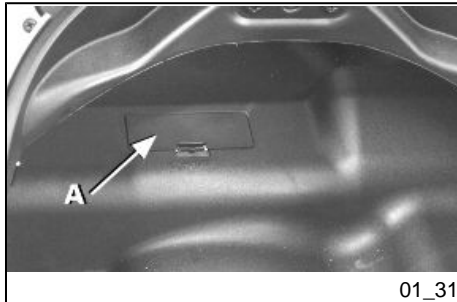

01\_31

## Identification (01\_31, 01\_32)

The identification registration numbers consist of a prefix stamped on the chassis and engine "B" respectively, followed by a number. These numbers must always be indicated on spare parts requests. To read the chassis number, remove the relevant port "A" in the helmet compartment. We recommend checking that the chassis registration number stamped on the vehicle corresponds with that on the vehicle documentation.

### CAUTION



**BE REMINDED THAT ALTERING IDENTIFICATION REGISTRATION NUMBERS CAN LEAD TO SERIOUS PENAL SANCTIONS (IMPOUNDING OF THE VEHICLE, ETC.).**

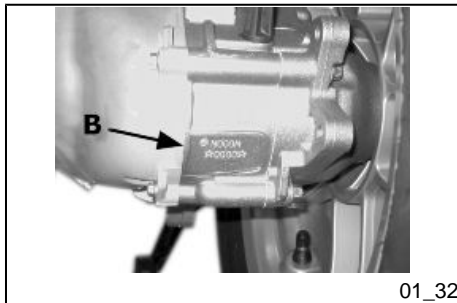

01\_32







# MP3 LT 400 i.e.



**PIAGGIO®**



**Chap. 02**  
**Use**

## Checks

Before using the vehicle, check:

1. That the fuel tank is full.
2. The correct fluid level for front and rear brakes.
3. That the tyres are properly inflated.
4. The correct functioning of tail lights, headlamp, turn indicators, stop light and license plate light.
5. The correct functioning of front and rear brakes.
6. The oil level in the in the gearcase.
7. The engine oil level.
8. The coolant level.

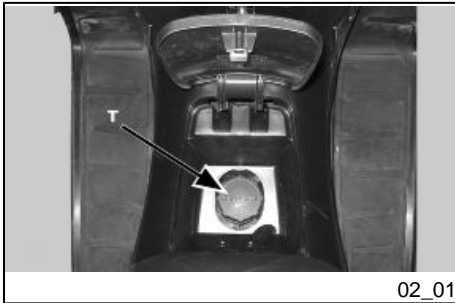

## Refuelling (02\_01, 02\_02)

**Fuel:** Open the access door to the fuel tank cap and remove the cap «T».

Recommended fuel: Unleaded petrol, min octane rating of 95. The instrument «H» indicates the fuel level and the warning light «M» indicates the reserve.

### WARNING



**SWITCH OFF THE ENGINE BEFORE REFUELLING WITH PETROL.**

**PETROL IS HIGHLY INFLAMMABLE.**

**DO NOT SMOKE AND KEEP NAKED FLAMES AT A DISTANCE: FIRE HAZARD.**

**DO NOT INHALE FUEL FUMES.**

**DO NOT ALLOW PETROL TO COME INTO CONTACT WITH HOT ENGINE OR ANY PLASTIC PARTS.**

**CAUTION**



**PETROL DAMAGES THE PLASTIC PARTS OF THE BODYWORK.**

**WARNING**



**DO NOT RIDE WITH THE FUEL TANK ALMOST EMPTY, LACK OF FUEL CAN DAMAGE THE CATALYTIC CONVERTER.**

**CAUTION**



**USING NON-RECOMMENDED PETROL REDUCES THE EFFICIENCY OF THE EXHAUST AND FUEL SUPPLY SYSTEMS.**

**CAUTION**



**DO NOT USE THE VEHICLE TO THE COMPLETE EXHAUSTION OF THE FUEL; SHOULD THIS OCCUR, DO NOT ATTEMPT TO START THE ENGINE. TURN THE KEY SWITCH TO «OFF» AND TOP-UP THE TANK AS SOON AS POSSIBLE. FAILURE TO FOLLOW THESE GUIDELINES COULD DAMAGE THE FUEL PUMP AND/OR THE CATALYTIC CONVERTER.**

**WARNING**

**IT IS HIGHLY INADVISABLE TO REFUEL USING METHODS OTHER THAN NORMAL FUEL PUMPS. IF PETROL IS NOT COMPLETELY CLEAN, IT CAN DAMAGE THE FUEL SUPPLY SYSTEM FILTERS.**

**CAUTION**

**USING OILS OTHER THAN THOSE RECOMMENDED CAN SHORTEN THE LIFE OF THE ENGINE.**

**Characteristic****Fuel tank capacity**

Tank capacity: ~12 l (approximate value)

**Fuel reserve**

2 l (approx.)



02\_02

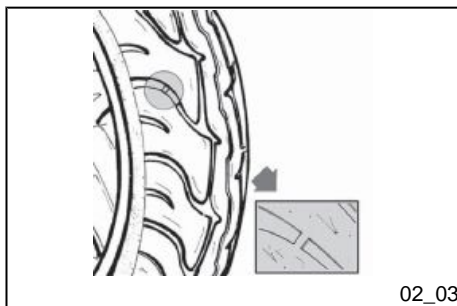

02\_03

### Tyre pressure (02\_03)

Check tyre pressure and wear periodically (roughly every 500 km). Tyres feature wear indicators; replace tyres as soon as these indicators become visible on the tyre tread. Also check that the tyres do not show signs of splitting at the sides or irregular tread wear; if this occurs, go to an authorised workshop or at least to a workshop equipped to replace tyres.

**CAUTION**

**TYRE PRESSURE SHOULD BE CHECKED WHEN TYRES ARE COLD. INCORRECT TYRE PRESSURE CAUSES ABNORMAL TYRE WEAR AND MAKES RIDING DANGEROUS.**

**TYRES MUST BE REPLACED WHEN THE TREAD REACHES THE WEAR LIMITS SET FORTH BY LAW.**

**CAUTION**

**"MICHELIN GOLD STANDARD" TYRES RECOMMENDED FOR THIS VEHICLE USING TYRES OTHER THAN THOSE INDICATED MAY CAUSE INSTABILITY.**

**Characteristic****Front tyre pressure**

1.6 bar

**Rear tyre pressure**

2.5 bar

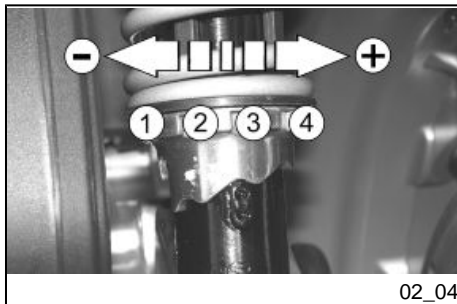
**Shock absorbers adjustment (02\_04)**

The preloading of the springs can be adjusted to 4 positions acting on the ring nut located in the lower part of the shock absorbers with the specific spanner supplied.

**Position 1:** minimum preload: driver only

**Position 2:** medium preloading: rider only

**Position 3:** medium preloading: rider and passenger

**Position 4:** maximum preloading: rider, passenger, and luggage.

02\_04

In order to carry out this operation you will need to use the specific spanner in the kit.

#### CAUTION



**RIDING THE VEHICLE WITH THE SPRING PRELOADING NOT CORRECTLY SET FOR THE RIDER AND POSSIBLE PASSENGER, COULD REDUCE THE COMFORT OF THE RIDE AND THE PRECISION OF THE STEERING.**

#### WARNING



**WE RECOMMEND WEARING GLOVES WHILE CARRYING OUT THIS OPERATION IN ORDER TO AVOID INJURIES.**

#### WARNING



**WE STRONGLY RECOMMEND NOT TO ADJUST BOTH SHOCK ABSORBERS WITH DIFFERENT PRELOADING**

## Running in

**DURING THE FIRST 1000 KM DO NOT RIDE THE VEHICLE OVER 80% OF ITS MAX. SPEED. AVOID OPENING THE THROTTLE GRIP COMPLETELY OR KEEPING A CONSTANT SPEED ALONG LONG SECTIONS OF ROAD. AFTER THE FIRST 1000 KM INCREASE SPEED PROGRESSIVELY, IF POSSIBLE, UNTIL THE MAXIMUM PERFORMANCE IS OBTAINED.**

## CAUTION



**IN ORDER TO AVOID DAMAGING THE VEHICLE, PLEASE COMPLY WITH THE RULES LISTED ABOVE.**

### **Starting up the engine (02\_05)**

The vehicle is supplied with an ignition cut-off system, activated by the emergency cut-off switch. The engine cannot be started if the ignition cut-off switch is in the **OFF** position.

A running engine automatically shuts off when the ignition cut-off switch is set to **OFF**.

The vehicle is equipped with automatic transmission with direct drive, so that starting is effected by turning the throttle grip to idle speed; to start-off from a stationary position, progressively twist the throttle grip. The vehicle is equipped with an electrical fuel pump that switches on automatically as soon as the engine is started. To start the vehicle, before pressing the starter button «**B**», pull and keep pulled the front brake lever «**D**» or the rear brake lever «**G**» that operates the corresponding ignition consent switches. Besides, if the vehicle has a front suspension locking system, a sensor placed under the saddle will prevent vehicle motion, but not ignition, if the rider is not seated in riding position.

1. Rest the vehicle on its centre stand, ensuring the rear wheel is not touching the ground.
2. Hold the throttle twist grip «**C**» in closed throttle position.
3. Insert the key into the ignition switch «**A**» and turn it to **ON** .
4. Ensure that the switch «**I**» is **ON**.
5. Pull either the front, «**D**», or rear brake lever, «**G**», then press the starter button «**B**».



**WARNING**

**THE AUTOMATIC TRANSMISSION MAKES THE REAR WHEEL TURN EVEN WHEN THE THROTTLE IS SLIGHTLY TWISTED. RELEASE THE BRAKE CAREFULLY AFTER STARTING, AND THEN ACCELERATE GRADUALLY.**

**CAUTION**

**DO NOT START-UP THE ENGINE IN CLOSED AREAS BECAUSE EXHAUST GASES ARE TOXIC.**

**CAUTION**

**DUE TO THE HIGH TEMPERATURES THE CATALYTIC CONVERTER CAN REACH, ALWAYS TAKE CARE, WHEN PARKING THE VEHICLE, THAT THE EXHAUST DOES NOT COME INTO CONTACT WITH FLAMMABLE MATERIALS, TO AVOID SERIOUS BURNS.**

**CAUTION**

**DO NOT SHUT OFF THE ENGINE WHILE THE VEHICLE IS MOVING. UNBURNED FUEL COULD ENTER THE CATALYTIC CONVERTER AND BURN, CAUSING THE CONVERTER TO OVERHEAT AND POSSIBLY DESTROYING IT.**

**CAUTION**

**NEITHER PUSH THE STARTER BUTTON NOR TURN THE KEY SWITCH TO «ON» WHEN THE TANK IS EMPTY SINCE THE START-UP SYSTEM MAY GET DAMAGED.**

**WARNING**

**NEVER TRY TO START-UP THE ENGINE WITH THE THROTTLE GRIP TWISTED. THIS MAY LEAD TO LOSING CONTROL OF THE VEHICLE AND TO ROLLOVER, WITH CONSEQUENT SERIOUS OR, IN SOME CASES, LETHAL INJURIES.**

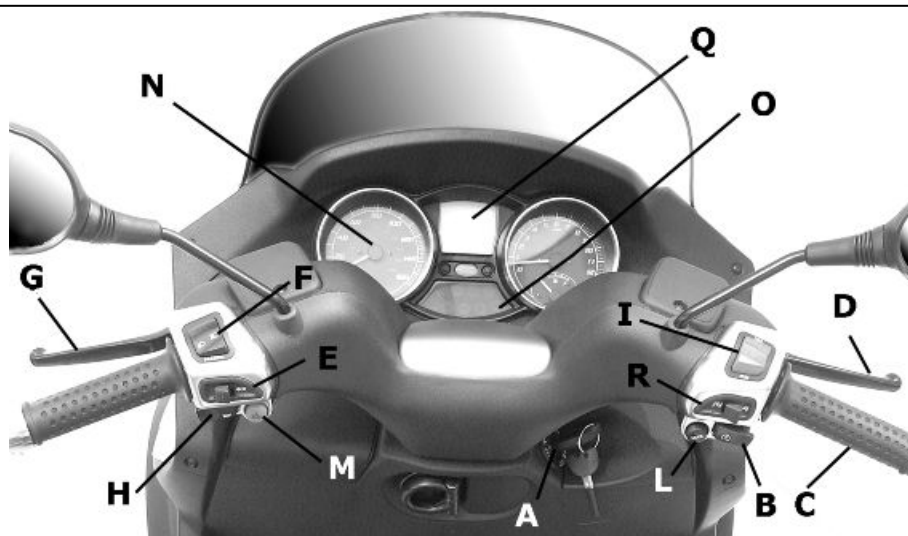

02\_05

## Precautions

### CAUTION



**NEVER STRESS THE ENGINE AT LOW TEMPERATURES IN ORDER TO AVOID POSSIBLE DAMAGE. BE CAREFUL NEVER TO EXCEED THE MAXIMUM SPEED WHILE RUNNING DOWNHILL, IN ORDER TO AVOID DAMAGING THE ENGINE. IN ANY CASE, IN ORDER TO PRESERVE THE ENGINE FROM PROLONGED OVERREVVING, THE REVOLUTION LIMITER WILL BE ACTIVATED IF THE ENGINE SPEED EXCEEDS THE ESTABLISHED THRESHOLD.**

**WARNING**

**AFTER A LONG DISTANCE COVERED AT THE MAXIMUM SPEED, DO NOT STOP THE ENGINE IMMEDIATELY, BUT LET IT RUN AT IDLE FOR A FEW SECONDS.**

**Difficult start up**

In the rare case of engine flooding, to facilitate start-up, it is possible to try to put the vehicle into action with the gas hand grip partially or completely open. It is however necessary, once the engine is started, to take your vehicle to an **Authorised Service Centre** to determine the cause of this problem and to re-establish the vehicle proper functioning.

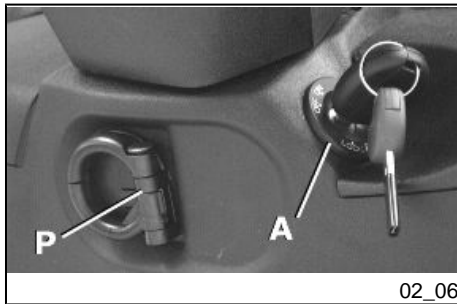
**Stopping the engine (02\_06)**

Fully untwist the throttle grip, then rotate the key in the switch «A » to «KEY OFF» (extractable key).

**CAUTION**

**DUE TO THE HIGH TEMPERATURES THE CATALYTIC CONVERTER CAN REACH, ALWAYS TAKE CARE, WHEN PARKING THE VEHICLE, THAT THE EXHAUST DOES NOT COME INTO CONTACT WITH FLAMMABLE MATERIALS, TO AVOID SERIOUS BURNS.**

**CAUTION**

**DO NOT SHUT OFF THE ENGINE WHILE THE VEHICLE IS MOVING. UNBURNED FUEL COULD ENTER THE CATALYTIC CONVERTER AND BURN, CAUSING THE CONVERTER TO OVERHEAT AND POSSIBLY DESTROYING IT.**

**Stand (02\_07)**

Push with your foot on the centre stand's fork «F» while lifting the vehicle backward, holding onto the handlebar.

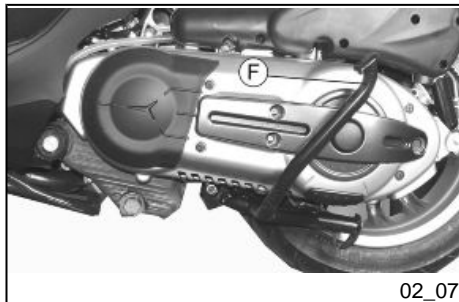
**Automatic transmission**

To ensure simple, pleasurable riding, the vehicle is equipped with automatic transmission with regulator and centrifugal clutch. The system is designed to provide the best performance (acceleration and consumption) while riding on both flat roads and uphill.

If you have to stop on an uphill slope (traffic lights, traffic jam, etc.) **use only the brake to keep the vehicle still, leaving the engine running at idle speed. Using the engine to keep the vehicle still can cause the clutch to overheat, due to the friction of the clutch masses against the capstan. Besides, avoid accelerating with the hand brake engaged.** It is therefore recommended to avoid conditions of prolonged clutch slippage (besides those previously indicated) like driving uphill fully

laden on steep slopes or starting off with driver and passenger at slopes greater than 25%.

Observe the following precautions if the clutch overheats:

1. Do not continue riding in such conditions.
2. Let the clutch cool down with the engine at idle speed for a few minutes.

## Safe driving

Some simple tips are provided below that will enable you to use your vehicle on a daily basis, confidently and safely. Your skill and your mechanical knowledge are the basis of safe riding. We recommend trying out the vehicle in traffic-free zones in order to acquire a good knowledge of the vehicle it self.

1. Before riding off, remember to put on your helmet and fasten it correctly.
2. Reduce speed on rough roads and ride with care.
3. After riding on a long stretch of wet road without using the brakes, braking can be poor at the beginning. In these conditions, it is a good idea to apply the brakes from time to time.
4. Avoid setting off by mounting the vehicle while it is resting on the support. In any case, the rear wheel should not be turning when it comes into contact with the ground, in order to avoid abrupt departures.
5. When riding the vehicle on roads with sand, mud, snow mixed with salt, etc., we recommend that you clean the brake disc frequently with a non-aggressive detergent in order to avoid the formation of abrasive build-ups in the holes, which could result in early wear of brake pads.

**CAUTION**

**ALWAYS RIDE WITHIN YOUR LIMITS RIDING UNDER THE INFLUENCE OF ALCOHOL OR OTHER DRUGS AND CERTAIN MEDICINES IS EXTREMELY DANGEROUS.**

**CAUTION**

**IN ORDER TO PREVENT ANY ACCIDENTS RIDE VERY CAREFULLY AFTER ADDING ACCESSORIES AND WHILE CARRYING LUGGAGE. ADDING ACCESSORIES AND LUGGAGE CAN REDUCE THE VEHICLE'S STABILITY, PERFORMANCE AND SAFETY DURING USE.**

**WARNING**

**NEVER RIDE THE VEHICLE WITH ADDED ACCESSORIES (CASE AND/OR WINDSHIELD) FASTER THAN 120 KM/H. WITHOUT THESE ACCESSORIES THE VEHICLE MAY BE DRIVEN AT A HIGHER SPEED WITHIN THE LEGAL LIMITS. IF THERE ARE NOT-PIAGGO ACCESSORIES FITTED, OR AN ABNORMAL LOAD, OR IF THE VEHICLE IS NOT IN A GENERALLY GOOD CONDITION, OR WHENEVER WEATHER CONDITIONS DEMAND IT, SPEED SHOULD BE FURTHER REDUCED.**

**CAUTION**

**DO NOT ADJUST THE MIRRORS WHILE RIDING. THIS COULD CAUSE YOU TO LOOSE CONTROL OVER THE VEHICLE.**

## CAUTION



ANY CHANGES TO THE VEHICLE PERFORMANCE AS WELL AS ALTERATIONS TO ORIGINAL STRUCTURAL PARTS IS STRICTLY FORBIDDEN BY LAW, AND RENDERS THE VEHICLE NO LONGER CONFORMING TO THE APPROVED TYPE AND DANGEROUS FOR RIDING.

### Front suspension locking system (02\_08, 02\_09, 02\_10, 02\_11, 02\_12)

The following section is applicable only to versions with front suspension locking system.

The front suspension locking system simply prevents vehicle tilting when the «T» switch is pressed. The vehicle can be stopped without your feet touching the ground.

The warning light «E» starts flashing when the key switch is set to «ON». This means that the system is enabled for locking activation.

When the «T» switch is turned to «1» a continuous sound alarm signals that the locking system is engaged and, at the same time, the warning light «E» turns on steadily.

When the «T» switch is turned to «2» an intermittent sound alarm signals that the locking system is disengaged and, at the same time, the warning light «E» starts flashing again. Warning light «E» turns off when riding starts. This means that the system allows for vehicle tilting.

Engaging tilt locking is possible only if the following conditions occur at the same time:

- Throttle completely untwisted
- Engine rpm below 2500 rpm
- Vehicle speed below 10 km/h
- Locking system WARNING light «Q» off (the system has not detected failures)



If one of these conditions is not checked, the warning light «E » remains off and locking cannot be engaged (in normal riding conditions, the warning light «E » is off).

With engine on, system locked and warning light «E » on, the suspension locking system is disengaged automatically and the warning light «E » turns off when the throttle is twisted to start the ride.

For riders' safety, the vehicle has a **rider detection sensor** in the saddle which enables the system to prevent vehicle motion and suspension unlocking (in case of locked suspension) when the rider is not properly seated in riding position: in such case, the WARNING light «Q » turns on steadily

#### CAUTION



**THE RIDER DETECTION SENSOR IS LOCATED IN THE FRONT PART OF THE SADDLE. AVOID PLACING BAGS OR HEAVY OBJECTS ACCIDENTALLY ON THE SADDLE.**

**NOT OBSERVING THIS RULE MAY MOVE THE VEHICLE FORWARD AND RELEASE THE SUSPENSION LOCKING SYSTEM EVEN IF THE RIDER IS NOT SEATED, BY SIMPLY TWISTING THE THROTTLE. THE VEHICLE COULD FALL ACCIDENTALLY AS A CONSEQUENCE.**

#### WARNING



**EVERY TIME THE VEHICLE IS STOPPED, MAKE SURE THE FRONT SUSPENSION LOCKING SYSTEM IS ENGAGED. OTHERWISE, PLACE YOUR FEET ON THE GROUND TO KEEP THE VEHICLE UPRIGHT.**

**WARNING**

**AVOID USING THE LOCKING SYSTEM WHEN RIDING THE VEHICLE ALONG IRREGULAR ROADS OR ROADS WITH OBSTACLES(E.G. ROAD HUMPS, SIDEWALK, ETC.).**

**IN CASE OF ENGINE FAILURE (DISCHARGED BATTERY) AVOID PULLING THE VEHICLE WITH THE LOCKING SYSTEM ENGAGED.**

**WITH THE LOCKING SYSTEM ENGAGED AND THE ENGINE OFF, AVOID MOVING THE VEHICLE AT SPEEDS ABOVE 5 Km/h.**

**WARNING**

**IF THE RIDER IS NOT SEATED ON THE SADDLE WHILE THE VEHICLE IS IN MOTION AND THE LOCKING SYSTEM IS ENGAGED, AVOID OPERATING THE THROTTLE CONTROL PURPOSELESSLY AS THIS MAY DAMAGE THE CATALYTIC CONVERTER.**

**CAUTION**

**DO NOT RIDE DOWNHILL WITH THE SUSPENSION LOCKING SYSTEM ENGAGED AND THE KEY SWITCH SET TO OFF.**



02\_08

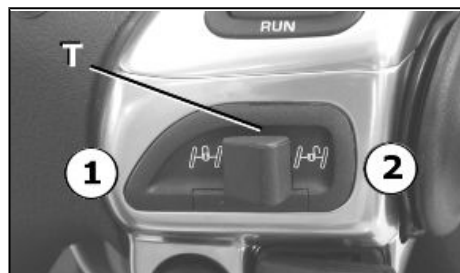

02\_09

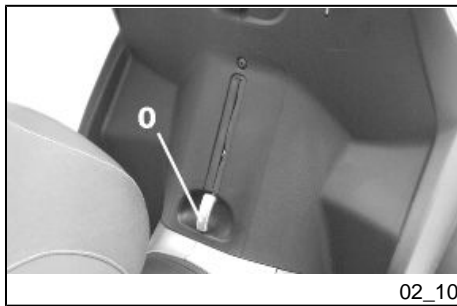

02\_10

With the vehicle off and the suspension locking system engaged, it is possible to get off the vehicle without using the stand. For safety reasons, engage the hand brake hand by pulling the lever shown in the figure from position «0» to position «1».

The warning light «R» on the instrument panel turns on when the hand brake is engaged.

When the hand brake is engaged and the key switch is turned to «1», a safety system is activated impeding release of the hand brake. To release the hand brake, turn the key switch to «2» or «3». If the switch is set to position «1», the hand brake can also be engaged.

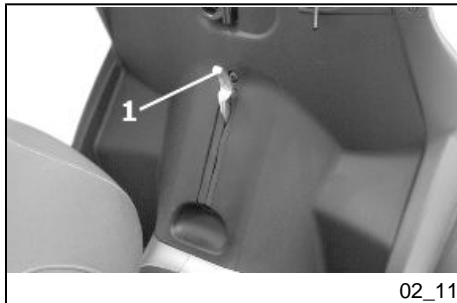

02\_11

If the WARNING light «Q» turns on (flashes), it means that there is a failure in the front suspension locking system. Therefore, it is necessary to contact an **Authorised Service Centre**. If the front suspension is locked, it can be unlocked by operating the «T» switch twice quickly on the unlocking position «2». Once the suspension is unlocked, the vehicle can be normally used, except for the locking system which will be disengaged.

For some cases of failure, the vehicle speed is auto-limited to 30 Km/h. This automatic procedure is activated to enhance safety until the failure is eliminated.

Always contact an **Authorised Service Centre**.

If the continuous sound alarm is activated when the WARNING light «Q» turns on (steadily), try to unlock the system by operating the «T» switch twice quickly on the unlocking position «2». If it cannot be unlocked, contact an **Authorised Service Centre**.

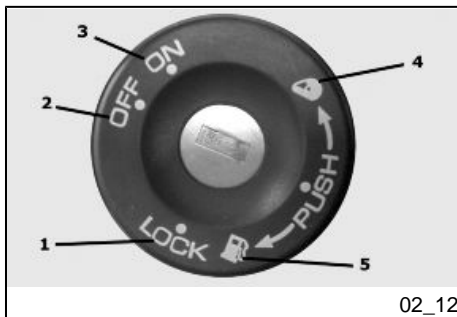

02\_12

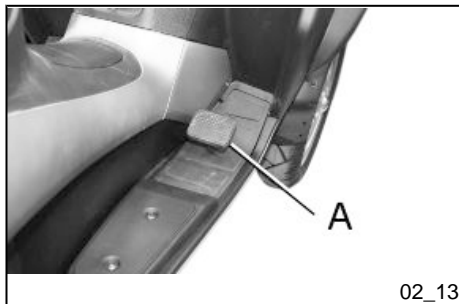

02\_13

## Integral pedal braking system (02\_13, 02\_14, 02\_15)

The vehicle is equipped with an integral braking system controlled by the brake pedal "A" located on the right hand footrest. Operating this pedal brakes both the front brake discs and the rear brake disc simultaneously.

The brake pedal functions simultaneously with the conventional braking system. As a result, any of the three braking controls may be used indifferently.

An optional "heelrest" kit is also available for optimised rider comfort. To install the heelrest, remove the rubber footrest mat and cut off approximately 20 cm of the mat. Using the screws, spacer and clamps provided, fix the plate as shown in the diagram.

### CAUTION

**AS THE SYSTEM IS LINKED TO THE CONVENTIONAL BRAKE PUMPS, OPERATING HANDLEBAR CONTROLS AND FOOT PEDAL MAY CAUSE A PERCEPTIBLE MOVEMENT OF THE BRAKE LEVERS AND VICE VERSA.**

**THIS IS NORMAL.**



02\_14

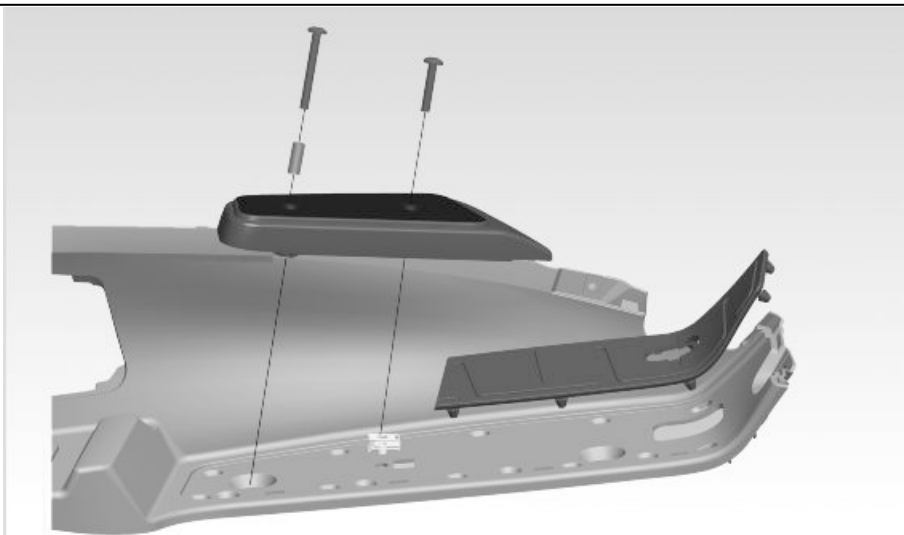

02\_15

# MP3 LT 400 i.e.



**PIAGGIO®**



**Chap. 03  
Maintenance**

## Engine oil level

In 4T engines, engine oil is used to lubricate the distribution elements, main bearings and thermal group. **An insufficient quantity of oil can seriously damage the engine.** In all four-stroke engines, a loss of efficiency in oil performance and certain consumption should be considered normal. Consumption can particularly reflect the conditions of use (i.e. when driving at 'full acceleration' all the time, oil consumption increases). The replacement intervals provided for by the maintenance programme are defined depending on the total content of oil in the engine and the average consumption measured following standardised methods. **In order to prevent any problems, we recommend checking oil level more frequently than indicated in the Scheduled Maintenance table or before setting off on long journeys. The vehicle is, however, equipped with an oil pressure warning light on the instrument panel.**

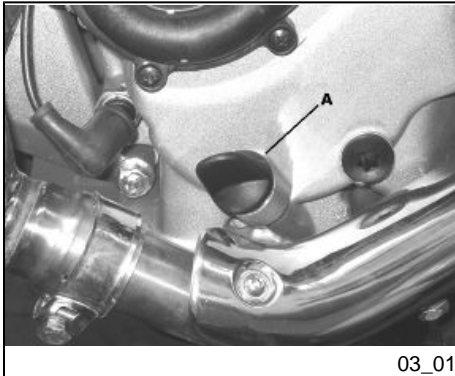

### Engine oil level check (03\_01, 03\_02)

Every time the vehicle is used, visually inspect the level of the engine oil when the engine is cold (after **completely unscrewing** the oil cap/dipstick). The oil level should be somewhere between the MAX and MIN index marks on the level rod; «A»; while the oil is being checked, the vehicle must be resting on its centre stand on an even, horizontal surface.

If the check is carried out after the vehicle has been used, and therefore with a hot engine, the level line will be lower; in order to carry out a correct check, wait at least 10 minutes after the engine has been stopped so as to get the correct level.



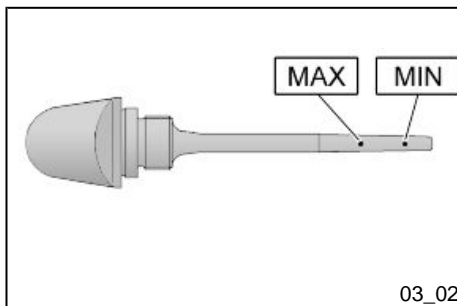

03\_02

### Engine oil top-up

Always check the oil level before carrying out top ups and add oil without exceeding the **MAX** level. Getting an oil level between the **MIN and MAX levels** requires ~ **400 cm<sup>3</sup>** of oil. An oil check-up and top-up should be carried out at any **Authorised Service Centre**, as indicated in the scheduled maintenance table.

### Warning light (insufficient oil pressure)

The vehicle is equipped with a warning light that comes on when the key is turned to «**ON**». However, this light should come off once the engine has been started. **If the light comes on while braking, at idle speed or while turning a corner, it is necessary to check the oil level and top it up if required. If after having topped-up the oil, the warning light still comes on while braking, at idle speed or while turning a corner, it will be necessary to take your vehicle to an Authorised Service Centre.**

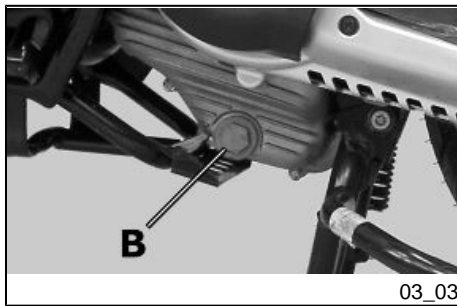

03\_03

## Engine oil change (03\_03, 03\_04, 03\_05)

The oil and the filter must be changed as indicated in the scheduled maintenance table at an **Authorised Service Centre**. The engine should be emptied by draining the oil via the drainage tap «**B**» of the mesh filter on the transmission side. In order to facilitate oil drainage, loosen the cap/dipstick «**A**». Unscrew and remove the oil cartridge filter. Install a new oil filter taking care to lubricate the sealing O-rings with engine oil. Since a certain quantity of oil still remains in the circuit, add approximately 1500 cm<sup>3</sup> of oil through cap «**A**». Then start up the vehicle, leave it running for a few minutes and switch it off: after 5 minutes, check the level and if necessary, top-up **without exceeding the MAX level**. The cartridge filter must be replaced at every oil change. For top-ups and oil changes, use new oil of the recommended type.

### CAUTION



**RUNNING THE ENGINE WITH INSUFFICIENT LUBRICATION OR WITH INADEQUATE LUBRICANTS ACCELERATES THE WEAR AND TEAR OF THE MOVING PARTS AND CAN CAUSE IRRETRIEVABLE DAMAGE.**

**TOPPING UP THE ENGINE WITH AN EXCESSIVE AMOUNT OF OIL MAY CAUSE MALFUNCTION AND/OR A DROP IN PERFORMANCE OF THE VEHICLE.**

**USING OILS OTHER THAN THOSE RECOMMENDED CAN SHORTEN THE LIFE OF THE ENGINE.**

### CAUTION



**USED OILS CONTAIN SUBSTANCES HARMFUL TO THE ENVIRONMENT. FOR OIL CHANGE, CONTACT AN AUTHORISED SERVICE CENTRE, WHICH IS EQUIPPED TO DISPOSE OF USED OILS IN AN ENVIRONMENTALLY FRIENDLY AND LEGAL WAY.**

### Recommended products

**AGIP CITY HI TEC 4T**

*Engine oil*

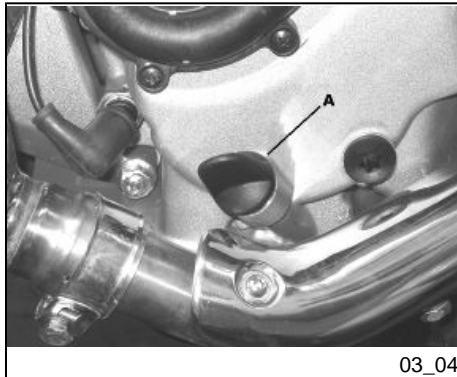

03\_04

SAE 5W-40, API SL, ACEA A3, JASO MA Synthetic oil

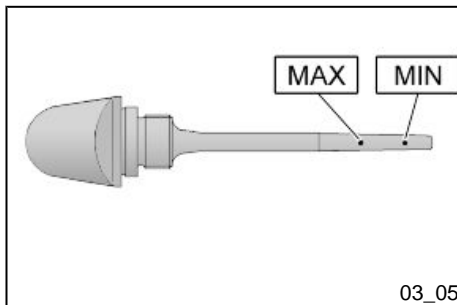

03\_05

### Hub oil level (03\_06, 03\_07)

Check the oil in the rear hub. (oil content ~ 250 cc). To check the rear hub oil level, proceed as follows:

- 1) Rest the vehicle onto its centre stand, on level ground.
- 2) Unscrew the dipstick «A», dry it with a clean cloth and then reinsert it **screwing it fully into place**.
- 3) Pull out the dipstick to control that the oil level reaches the second notch from the bottom, as indicated by the arrow in figure, this is the correct level and must remain constant at all times.
- 4) Screw the dipstick back in, checking that it is correctly locked in place.

#### CAUTION



**RIDING THE VEHICLE WITH INSUFFICIENT HUB LUBRICATION OR WITH CONTAMINATED OR IMPROPER LUBRICANTS ACCELERATES THE WEAR AND TEAR OF THE MOVING PARTS AND CAN CAUSE SERIOUS DAMAGE.**

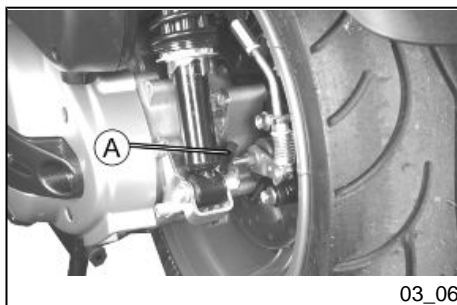

03\_06

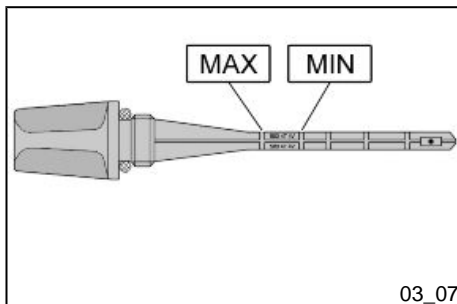

03\_07

**CAUTION**

USED OIL CAN HARM THE ENVIRONMENT. COLLECTION AND DISPOSAL SHOULD BE CARRIED OUT IN COMPLIANCE WITH REGULATIONS IN FORCE.

**CAUTION**

AN EXCESSIVE QUANTITY OF OIL CAN LEAD TO SPILL OVER, WHICH MAY CAUSE THE ENGINE AND THE WHEEL TO GET DIRTY.

**CAUTION**

WHEN REPLACING THE HUB OIL DO NOT LET THE OIL COME INTO CONTACT WITH THE REAR BRAKE DISC.

**CAUTION**

FOR OIL REPLACEMENT, CONTACT ANY AUTHORISED SERVICE CENTRE AS THEY ARE EQUIPPED TO DISPOSE OF USED OILS IN AN ENVIRONMENTALLY FRIENDLY AND LEGAL WAY.

**Recommended products**

**AGIP ROTRA 80W-90**

*Rear hub oil*

SAE 80W/90 Oil that exceeds the requirements of API GL3 specifications

## Characteristic

### Transmission oil

250 cm<sup>3</sup>

### Tyres (03\_08)

Check tyre pressure and wear periodically (roughly every 500 km). Tyres feature wear indicators; replace tyres as soon as these indicators become visible on the tyre tread. Also check that the tyres do not show signs of splitting at the sides or irregular tread wear; if this occurs, go to an authorised workshop or at least to a workshop equipped to replace tyres.

#### CAUTION



**TYRE PRESSURE SHOULD BE CHECKED WHEN TYRES ARE COLD. INCORRECT TYRE PRESSURE CAUSES ABNORMAL TYRE WEAR AND MAKES RIDING DANGEROUS.**

**TYRES MUST BE REPLACED WHEN THE TREAD REACHES THE WEAR LIMITS SET FORTH BY LAW.**

#### WARNING



**THE WHEELS FITTED WITH TYRES SHOULD ALWAYS BE BALANCED. RIDING THE VEHICLE WITH VERY LOW TYRE PRESSURE OR WITH INCORRECTLY BALANCED TYRES CAN LEAD TO DANGEROUS STEERING VIBRATIONS.**

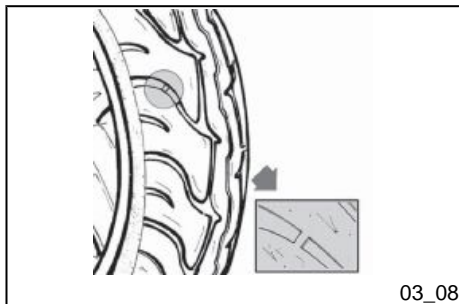

## TYRES

|            |                                 |
|------------|---------------------------------|
| Front tyre | Tubeless, 120/70-12" 51S or 51P |
| Rear tyre  | Tubeless 120/70-14" 68S or 68P  |

## TYRE INFLATION PRESSURE

|                     |         |
|---------------------|---------|
| Front tyre pressure | 1.6 bar |
| Rear tyre pressure  | 2.5 bar |



### **Spark plug dismantlement (03\_09, 03\_10)**

Remove the port on the left-hand side panel of the vehicle by undoing the fixing screw «A» and using a small screwdriver in the rear notch shown in the figure, then proceed as follows:

1. Disconnect spark plug HV wire cap «B»;
2. Unscrew the spark plug using the wrench supplied.;
3. When refitting, place the spark plug in the hole at the due inclination and tighten it by hand until it is finger tight;
4. Only use the wrench to lock it in place;
5. Place cap «B» fully over the spark plug.
6. Refit the port making sure the rear hook is inserted.

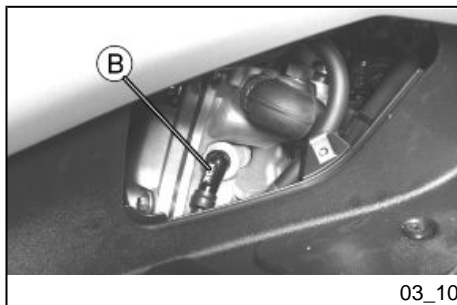
**WARNING**

**SPARK PLUG MUST BE REMOVED WHEN THE ENGINE IS COLD. REPLACE THE SPARK PLUG AS INDICATED IN THE SCHEDULED MAINTENANCE TABLE. THE USE OF ELECTRONIC CENTRAL UNITS AND OF NON-COMPLIANT ELECTRONIC IGNITIONS OR SPARK PLUGS OTHER THAN THOSE PRESCRIBED MAY SERIOUSLY DAMAGE THE ENGINE.**

**N.B.**

**USING SPARK PLUGS OTHER THAN THE INDICATED TYPE OR SHIELDLESS SPARK PLUG CAPS CAN CAUSE ELECTRICAL SYSTEM FAILURES.**

**Characteristic****Spark plug**

CHAMPION RG 6 YC

**Alternative spark plug**

NGK CR7EKB

**Electric characteristic****Electrode gap**

0.7 ÷ 0.8 mm

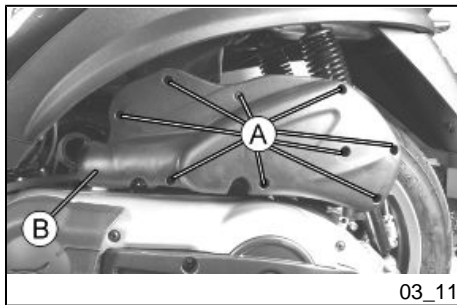

## Removing the air filter (03\_11)

Proceed as follows:

Unscrew the nine fixing screws «A» and remove the air filter cover «B».

## Air filter cleaning

1. Wash the sponge with water and mild soap.
2. Dry it with a clean cloth and short blasts of compressed air.
3. Impregnate the sponge with a mixture of 50% petrol and 50% specified oil.
4. Gently squeeze the filtering element, let it drip dry and then refit it.

### CAUTION



**IF THE VEHICLE IS USED ON DUSTY ROADS, IT IS NECESSARY TO SERVICE THE AIR FILTER MORE OFTEN TO AVOID DAMAGING THE ENGINE.**

## Recommended products

### AGIP FILTER OIL

*Oil for air filter sponge*

Mineral oil with specific additives for increased adhesiveness



## Cooling fluid level (03\_12, 03\_13, 03\_14, 03\_15)

The engine cooling system operates by forcing circulation of fluid. The cooling circuit contains about 2 litres of coolant consisting of a mixture of 50% de-ionised water and glycol ethylene-based antifreeze solution with corrosion inhibitors. Recommended coolant: supplied with the vehicle, already mixed and ready for use. For proper engine functioning, the coolant temperature must be between the 4th and 7th lit segment, as indicated by the instrument «D» on the digital instrument panel. When the 9th segment lights up, the icon and all the segments start flashing; stop the engine, let it cool down and check the fluid level; if the result is normal, take your vehicle to an **Authorised Piaggio Service Centre**.

The fluid inspection should be carried out every 6,000 km when the engine is cold, following the methods indicated below.

- Rest the vehicle in vertical position on the stand and remove the screw of the expansion tank cap shown in the photo
- Remove the expansion tank cover «A», turning in anticlockwise.
- Look inside the expansion tank: the fluid level must always be between the min and the max level
- If the coolant level is near the minimum mark, top up when the engine is cold.

If the coolant needs to be topped up frequently or the expansion tank is completely dry, check the cooling system to find the cause of the problem. It is therefore indispensable to have the cooling system checked at an **Authorised Piaggio Service Centre**. The coolant should be replaced every 2 years. Take your vehicle to an **Authorised Piaggio Service Centre** for this operation.

### N.B.

**SHOULD THE 9th SEGMENT OF THE COOLANT TEMPERATURE INDICATOR COME ON DURING A NON-DEMANDING RIDE, SHUT OFF THE ENGINE AND LET IT COOL DOWN. THEN CHECK THE COOLANT LEVEL; IF THE LEVEL IS OK, CONTACT AN AUTHORISED SERVICE CENTRE.**



03\_12

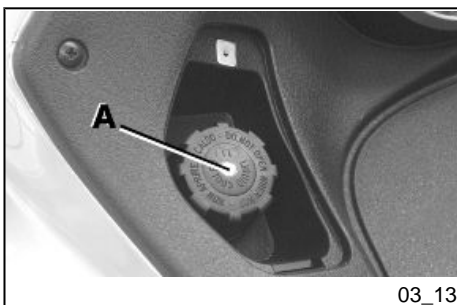

03\_13

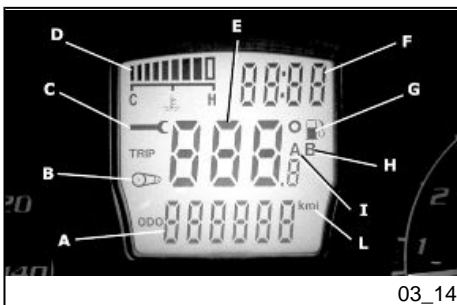

03\_14

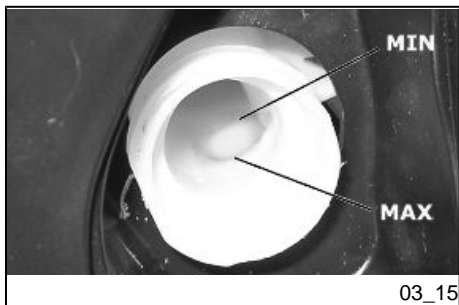

03\_15

**WARNING**

TO AVOID THE RISK OF SCALDING, DO NOT UNSCREW THE EXPANSION TANK COVER WHILE THE ENGINE IS STILL HOT.

**WARNING**

TO PREVENT AVOID HARMFUL FLUID LEAKAGE WHILE RIDING, ENSURE THAT THE LEVEL NEVER EXCEEDS THE MAXIMUM VALUE.

TO ENSURE CORRECT ENGINE OPERATION, KEEP THE RADIATOR GRILLE CLEAN.

**Recommended products****AGIP PERMANENT SPEZIAL***coolant*

Monoethylene glycol-based antifreeze fluid, CUNA NC 956-16

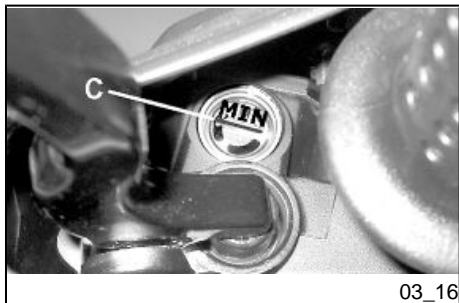

03\_16

**Checking the brake oil level (03\_16, 03\_17, 03\_18)**

The front and rear brake fluid reservoirs are both positioned on the handlebar. Proceed as follows:

1. Rest the vehicle on its centre stand with the handlebars perfectly horizontal;
2. Check the liquid through the sight glass «C».

To check the integral braking system fluid level, remove the cover on the right hand side of the footrest, undoing the screw "D". Check the brake fluid level in the reservoir "E"

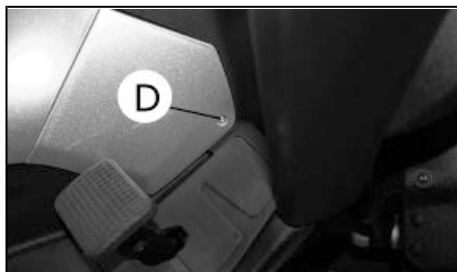

03\_17

A drop in the brake fluid level may be caused by pad wear. Should the level appear to be below the minimum mark, please contact an **Authorised Service Centre or Dealer** in order to have the braking system thoroughly checked.



03\_18

### Braking system fluid top up (03\_19, 03\_20, 03\_21)

Proceed as follows:

Loosen the screw «**B**» and lift the plastic cover «**A**» in order to access the brake fluid reservoir. Loosen the two fastener screws and remove the reservoir cap and top up with the recommended fluid only.

This procedure applies to the rear brake pump top-up operation; follow the same procedure for the front brake pump.

To top up the integral braking system brake fluid, partially remove the fluid reservoir from its mounting, taking care not to detach the pipe. Loosen screw "**F**", lift out the reservoir as shown in the photo and remove the cap to top up the fluid level.



03\_19



03\_20

Under normal climatic conditions, the brake fluid should be changed every 2 years.

This operation must be carried out by trained personnel; take your vehicle to an **authorised Service centre or Dealer**.

#### WARNING



**ONLY USE DOT 4-CLASSIFIED BRAKE FLUID. BRAKE CIRCUIT FLUID IS VERY CORROSIVE; MAKE SURE THAT IT DOES NOT COME INTO CONTACT WITH THE PAINTWORK**

#### CAUTION



**AVOID CONTACT OF BRAKE FLUID WITH EYES, SKIN, AND CLOTHING. IN CASE OF CONTACT, RINSE WITH WATER. THE BRAKING CIRCUIT FLUID IS HYGROSCOPIC, THAT IS, IT ABSORBS HUMIDITY FROM THE SURROUNDING AIR. IF THE HUMIDITY IN THE BRAKING FLUID EXCEEDS A CERTAIN VALUE, IT WILL LEAD TO INEFFICIENT BRAKING. NEVER USE BRAKING FLUID KEPT IN CONTAINERS THAT HAVE ALREADY BEEN OPENED, OR PARTIALLY USED.**

#### Recommended products

##### **AGIP BRAKE 4**

*Brake fluid*

FMVSS DOT 4 Synthetic fluid



03\_21

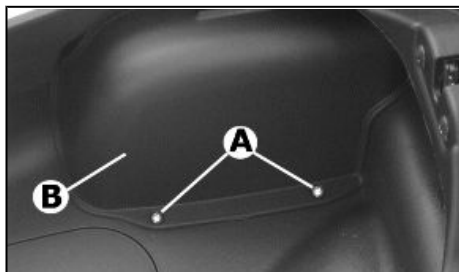

03\_22

## Battery (03\_22)

To access the battery, proceed as follows:

1. Place the vehicle on its centre stand;
2. Open the saddle, following the previously described procedure;
3. Remove the two fasteners "A" and the cover "B".

### WARNING



**IN ORDER TO AVOID DAMAGING THE ELECTRICAL SYSTEM, NEVER DISCONNECT THE WIRING WHILE THE ENGINE IS RUNNING.**

## Use of a new battery

Make sure that the terminals are connected correctly.

### CAUTION



**DO NOT REVERSE THE POLARITY: RISK OF SHORT CIRCUIT AND DAMAGE TO THE ELECTRICAL SYSTEM.**

### WARNING



**USED BATTERIES ARE HARMFUL FOR THE ENVIRONMENT. COLLECTION AND DISPOSAL SHOULD BE CARRIED OUT IN COMPLIANCE WITH REGULATIONS IN FORCE.**

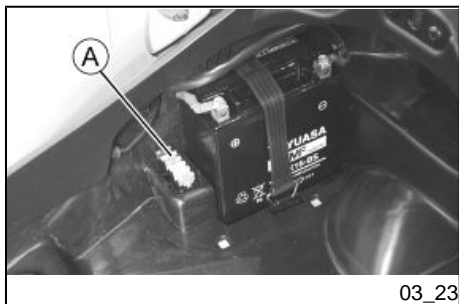

03\_23

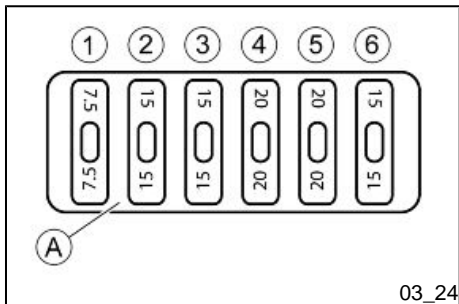

03\_24

## Long periods of inactivity

If the vehicle has not been used for long periods, it is necessary to periodically recharge the battery, bearing in mind that the battery tends to go completely flat within around three months. The battery must be recharged with a current load equal to 1/10 of the battery rated capacity (~ 1A ), for a period not longer than 8 hours. For this operation contact an **Authorised Service Centre**. When refitting a removed battery, make sure that all terminals are properly connected.

## Fuses (03\_23, 03\_24, 03\_25, 03\_26, 03\_27)

The electrical system has twelve fuses divided into two fuse boxes to protect the different installation circuits. One of them is inside the battery compartment «A» and the other is at the internal side of the right footrest «B». To have access, loosen the screw «C» and remove the plastic cover. The chart shows the position and characteristics of the fuses in the vehicle.

### CAUTION



**BEFORE REPLACING A BLOWN FUSE, FIND AND SOLVE THE FAILURE THAT CAUSED IT TO BLOW. NEVER TRY TO REPLACE THE FUSE WITH ANY OTHER MATERIAL (E.G., A PIECE OF ELECTRIC WIRE).**

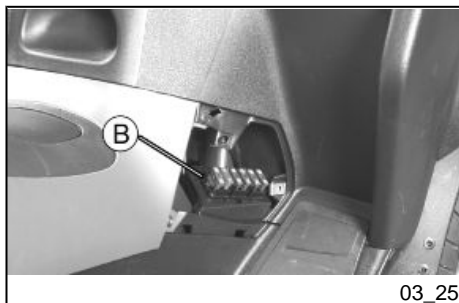

03\_25

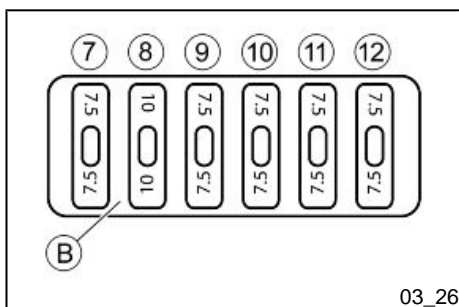

03\_26



03\_27

## FUSE TABLE

|            |   |
|------------|---|
| Fuse No. 1 | <b>Capacity: 7.5 A</b><br><b>Protected circuits:</b> Injection ECU<br>battery power   |
| Fuse No. 2 | <b>Capacity: 15 A</b><br><b>Protected circuits:</b> Battery-<br>powered injection loads, electrical<br>fan  |
| Fuse No. 3 | <b>Capacity: 15 A</b><br><b>Protected circuits:</b> Saddle<br>opening receiver battery power<br>supply, glove box lighting,<br>headlight, turn indicator command<br>device, pre-installation for anti-<br>theft device.<br><br>Live fuse No.12, saddle opening<br>and boot. |
| Fuse No. 4 | <b>Capacity: 20A</b><br><b>Protected circuits:</b> battery-<br>powered ECU for parking control  |
| Fuse No. 5 | <b>Capacity: 20A</b><br><b>Protected circuits:</b> battery-<br>powered fuse No. 7, live fuses No.<br>8 - 9 - 10 - 11  |
| Fuse No. 6 | <b>Capacity: 15 A</b>   |



**Protected circuits:**L.V. socket.

|             |   |
|-------------|---|
| Fuse No. 7  | <p><b>Capacity: 7.5 A</b></p> <p><b>Protected circuits:</b>Battery-powered instrument panel</p>   |
| Fuse No. 8  | <p><b>Capacity: 10A</b></p> <p><b>Protected circuits:</b>Live stop, start-up and start-up enabling lights.</p>  |
| Fuse No. 9  | <p><b>Capacity: 7.5 A</b></p> <p><b>Protected circuits:</b>live passing and horn</p>  |
| Fuse No. 10 | <p><b>Capacity: 7.5A</b></p> <p><b>Protected circuits:</b>Live injection ECU, immobilizer aerial, electric fan remote control, injection load remote control</p>                                |
| Fuse No. 11 | <p><b>Capacity: 7.5A</b></p> <p><b>Protected circuits:</b>Live parking control ECU, pre-installation for anti-theft device, instrument panel, headlight remote control, horn remote control</p> |
| Fuse No. 12 | <p><b>Capacity: 7.5A</b></p> <p><b>Protected circuits:</b>Live turn indicator control, saddle opening switch, tail lights, panel lighting</p>   |

### LIGHT BULBS TABLE

|                                |  |
|--------------------------------|--|
| Low-beam bulb                  | <b>Type:</b> HALOGEN (H1)<br><b>Power:</b> 12V - 55W<br><b>Quantity:</b> 1                           |
| High-beam light bulb           | <b>Type:</b> HALOGEN (H1)<br><b>Power:</b> 12V - 55W<br><b>Quantity:</b> 1                           |
| Helmet compartment light bulb  | <b>Type:</b> FESTOON BULB<br><b>Power:</b> 12V - 5W<br><b>Quantity:</b> 1                            |
| Rear turn indicator light bulb | <b>Type:</b> Incandescent (BAU 15s)<br><b>Power:</b> 12V - 10W<br><b>Quantity:</b> 1 RHS + 1 LHS     |
| Rear tail light bulb           | <b>Type:</b> Incandescent (W2.1 x 9.5 d)<br><b>Power:</b> 12V - 5W<br><b>Quantity:</b> 1 RHS + 1 LHS |
| Stop light bulb                | <b>Type:</b> Incandescent (BAU 15s)<br><b>Power:</b> 12V - 10W                                       |

**Quantity: 2**

License plate bulb

**Type:** Incandescent**Power:** 12V - 5W**Quantity:**2

Front turn indicator bulb

**Type:** Incandescent (BAU 15s)**Power:** 12V - 10W**Quantity:** 1 RHS + 1 LHS

Front tail light bulb

**Type:** Incandescent (W2.1x9.5d)**Power:** 12V - 5W**Quantity:** 1

Instrument panel bulb

**Type:** Incandescent**Power:** 12V - 2W**Quantity:**4

### Front light group (03\_28, 03\_29, 03\_30, 03\_31, 03\_32, 03\_33, 03\_34, 03\_35, 03\_36, 03\_37)

To remove the front headlight assembly, proceed as follows:

1. Remove the Piaggio clip-on badge
2. Remove the screw «A» and the headlight assembly central cover
3. Remove the two headlamp upper fixing screws «B»
4. Remove the two grille front fixing screws «C»
5. Remove the two grille surround fastener screws «D»
6. Remove the two screws «E» located under the position light
7. Remove the two screws «F» located inside the front shield

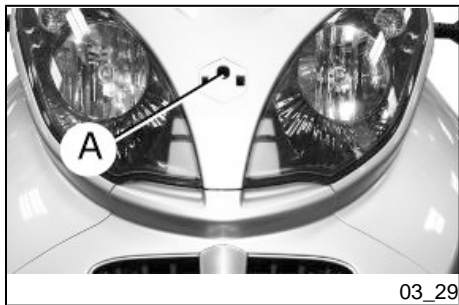

8. Remove the grille surround
9. Remove the two lower headlight fastener screws «G»
10. Take out the front headlight assembly

Refit the components following the above operations in reversed order

**WARNING**



**HIGH- AND LOW-BEAM BULBS ARE HALOGEN TYPE: DO NOT TOUCH THEM WITH YOUR FINGERS TO AVOID DAMAGING THEIR FUNCTION.**

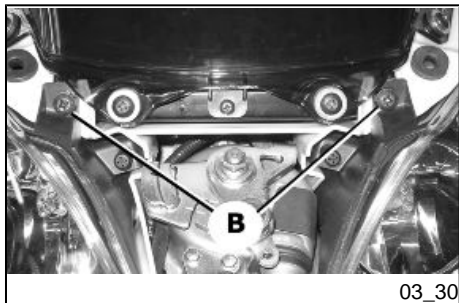



03\_32

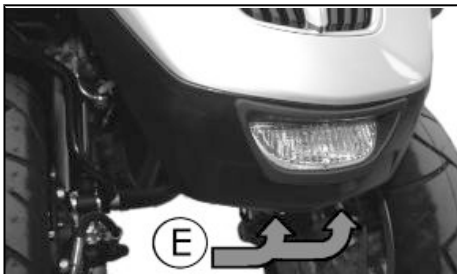

03\_33

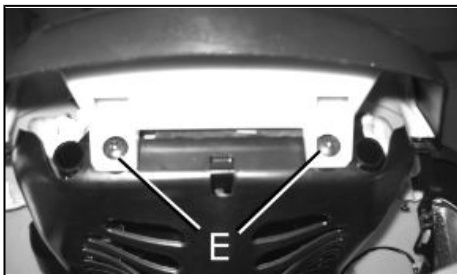

03\_34

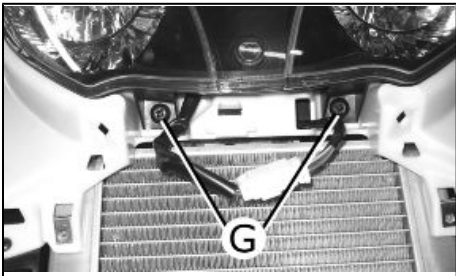

03\_35

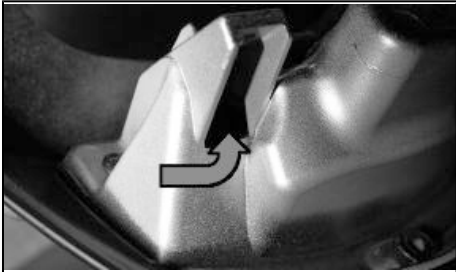

03\_36

To remove the front position light, move the retainer tabs, which are accessible from the rear of the running light mounting. Remove the assembly, complete with light bulb.



03\_37

### Headlight adjustment (03\_38, 03\_39)

Proceed as follows:

1. Position the unloaded vehicle, in running order and with the tyres inflated to the prescribed pressure, on a flat surface 10 m away from a half-lit white screen; ensure that the longitudinal axis of the vehicle is perpendicular to the screen;
2. Remove the headlight assembly central cover
3. Turn on the headlight and check that the limit of the projected light beam is not over 9/10 or below 7/10 of the distance from the ground to the centre of the vehicle headlight;
4. Otherwise, adjust the headlight with the screws «A» indicated in the figure

#### N.B.

THE ABOVE PROCEDURE COMPLIES WITH THE EUROPEAN STANDARDS REGARDING MAXIMUM AND MINIMUM HEIGHT OF LIGHT BEAMS. REFER TO THE STATUTORY REGULATIONS IN FORCE IN EVERY COUNTRY WHERE THE VEHICLE IS USED.

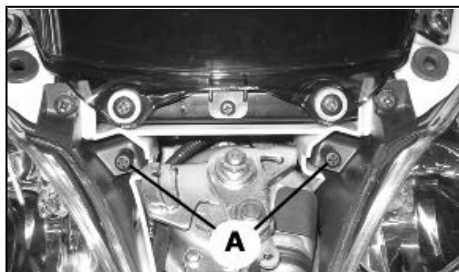

03\_38

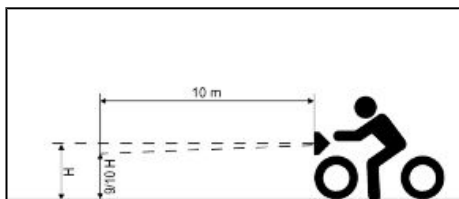

03\_39

### Front direction indicators (03\_40)

To access the bulb, undo the screw «A» and remove the glass «B».

To replace the bulb, hold it and then turn it clockwise.

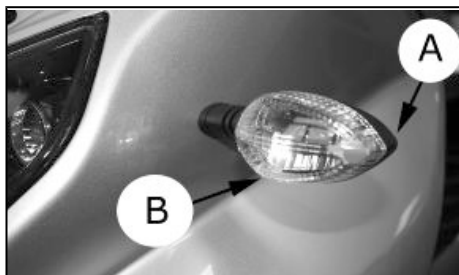

03\_40

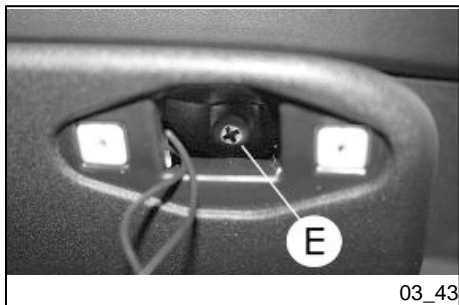
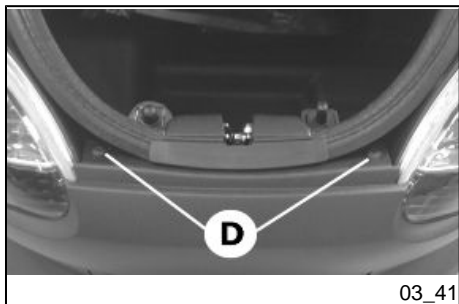

## Rear optical unit (03\_41, 03\_42, 03\_43, 03\_44, 03\_45, 03\_46, 03\_47)

To remove the rear light unit, proceed as follows:

- open the rear compartment cover and remove the two screws «D»,
- remove the two license plate light bulb mounts by loosening screws "C"
- remove the two screws "E" and remove the license plate light mount "F" and rear cover "G"
- loosen screw "H" and remove the light unit from its mounting.

Follow this procedure to remove the bulbs:

Remove the snap-on bulbs «B».

Remove the bulbs «A» on the bayonet by turning them 30° clockwise.





03\_44

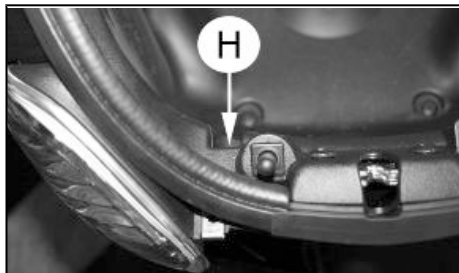

03\_45



03\_46

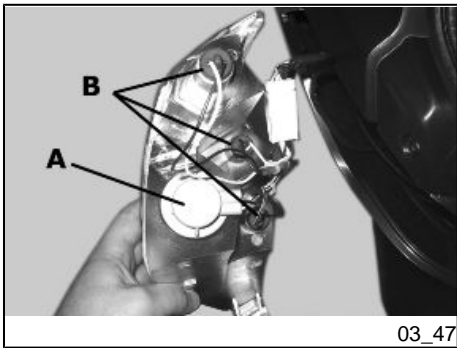

### Rear turn indicators (03\_48)

Remove the screw "A", then remove the turn indicator lens. Remove the bulb.

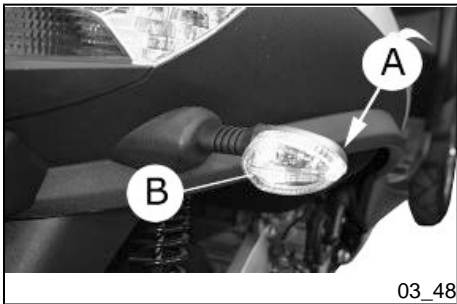

### Number plate light (03\_49, 03\_50)

To replace the license plate light bulbs, remove the two screws "C", then remove the bulb



03\_49



03\_50

### Helmet compartment lighting bulb (03\_51)

Open the rear compartment and insert a small plain slot screwdriver in the lateral notch to detach the snap-on glass «D», then replace the bulb.



03\_51

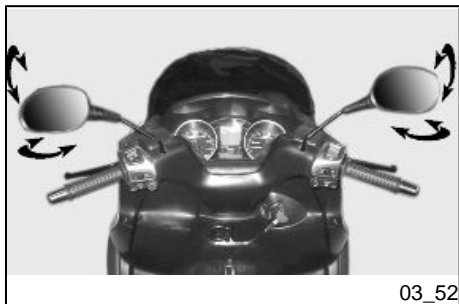

### Rear-view mirrors (03\_52)

The mirrors can be set to the desired position by adjusting the mirror frame.

### Front and rear disc brake

The brake disc and pad wear is automatically compensated, therefore it has no effect on the functioning of the front and rear brakes. For this reason it is not necessary to adjust the brakes. An excessively elastic brake lever stroke may indicate the presence of air in the braking circuit or a failure in the braking system. In this case, mainly due to the importance of brakes to guarantee safe riding conditions, the vehicle should be taken to an **Authorised Service Centre or Dealer**.

#### CAUTION



**BRAKING SHOULD BEGIN AFTER ABOUT 1/3 OF THE BRAKE LEVER STROKE.**

#### CAUTION



**HAVE THE BRAKE PADS CHECKED BY THE DEALER ACCORDING TO THE CHECKS SPECIFIED IN THE SCHEDULED MAINTENANCE TABLE. HOWEVER, IN THE EVENT OF NOISES COMING FROM THE FRONT AND/OR REAR BRAK-**

ING SYSTEM DURING OPERATION, IT IS ADVISABLE TO HAVE THE BRAKING SYSTEM CHECKED BY AN AUTHORISED SERVICE CENTRE OR DEALER. AFTER REPLACING THE BRAKE PADS, DO NOT USE THE SCOOTER UNTIL YOU HAVE OPERATED THE BRAKE LEVER SEVERAL TIMES IN ORDER TO ALLOW THE PLUNGERS TO SETTLE AND THE LEVER STROKE TO BE SET TO THE CORRECT POSITION.

#### CAUTION



THE PRESENCE OF SAND, MUD, SNOW MIXED WITH SALT, ETC. ON THE ROAD, CAN DRASTICALLY REDUCE THE LIFE OF THE BRAKE PADS. IN ORDER TO AVOID THIS, WE RECOMMEND WASHING THE VEHICLE FREQUENTLY WHEN RIDING IN THESE ROAD CONDITIONS.

### Puncture

The vehicle is equipped with Tubeless tyres (without inner tube). In the event of a puncture, Tubeless tyres - unlike tyres with inner tubes - go flat very slowly, resulting in a greater steering safety. In the event of a puncture, an emergency repair can be carried out using an "inflate and repair" spray can. For a final repair, take your vehicle to an **Authorised Service Centre or Dealer**. The replacement of a tyre involves removing the wheel in question. Take your vehicle to an **Authorised Service Centre or Dealer** for these operations.

#### CAUTION



TO USE THE "INFLATE AND REPAIR" SPRAY CAN PROPERLY, FOLLOW THE INSTRUCTIONS ON THE PACKAGING.

**WARNING**

**THE WHEELS FITTED WITH TYRES SHOULD ALWAYS BE BALANCED. RIDING THE VEHICLE WITH VERY LOW TYRE PRESSURE OR WITH INCORRECTLY BALANCED TYRES CAN LEAD TO DANGEROUS STEERING VIBRATIONS.**

**Periods of inactivity**

We recommend carrying out the following operations:

1. Clean the scooter thoroughly and then cover it with a canvas;
2. When placing the vehicle on its centre stand, ensure that the front suspension locking system is disengaged;
3. With engine off and piston at the bottom dead centre, remove the spark plug, add 1÷2 cm<sup>3</sup> of oil through its hole (larger amounts are dangerous for the engine itself). Operate the starter button 1-2 times for roughly 1 second to turn the engine over slowly, then insert the spark plug again;
4. Drain all fuel from the vehicle; spread antirust grease on the unpainted metal parts; keep the wheels lifted above the ground by resting the chassis on two wooden wedges;
5. Concerning the battery, follow the instructions in the «Battery» section.

**Recommended products****AGIP CITY HI TEC 4T**

*Oil to lubricate flexible transmissions (throttle control)*

Oil for 4-stroke engines

## Cleaning the vehicle

Use a low pressure jet of water to soften the caked dirt and mud deposited on the painted surfaces. Once softened, sponge off mud and dirt using a car body sponge soaked in a car body shampoo and water solution (2-4% of car shampoo in water). Then rinse with abundant water, and dry with a shammy cloth. For the engine exterior, use petrol, a brush and clean cloths. Petrol can damage paintwork. Remember that any polishing with silicone wax must always be preceded by washing.

### CAUTION



**DETERGENTS CAN POLLUTE WATER. THE VEHICLE MUST BE WASHED AT A WASH STATION EQUIPPED WITH A SPECIAL WATER PURIFICATION SYSTEM.**

### CAUTION



**THE USE OF A HIGH-PRESSURE WATER JET IS STRONGLY DISCOURAGED FOR ANY ENGINE CLEANING OPERATION; HOWEVER, IF NO OTHER MEANS ARE AVAILABLE, IT IS THEN NECESSARY TO:**

- **ONLY USE A FANLIKE SPRAY JET.**
- **DO NOT HOLD THE NOZZLE NEARER THAN 2 FT (60 CM) FROM THE VEHICLE.**
- **DO NOT USE WATER AT TEMPERATURES OVER 100°F (40°C).**
- **DO NOT USE HIGH-PRESSURE WATER JETS.**
- **DO NOT STEAM WASH.**
- **DO NOT AIM THE JET AT: THE ENGINE, THE WIRING, THE SLOT DIFFUSER ON THE TRANSMISSION OR SCROLL COVERS.**

## CAUTION



NEVER WASH THE SCOOTER IN DIRECT SUNLIGHT, ESPECIALLY IN SUMMER WHEN THE BODYWORK IS STILL HOT AS THE SHAMPOO COULD DAMAGE THE PAINTWORK IF IT DRIES BEFORE BEING RINSED OFF. NEVER USE CLOTHS SOAKED IN ALCOHOL, PETROL, DIESEL OIL OR KEROSENE FOR CLEANING THE PAINTED OR PLASTIC SURFACES, IN ORDER NOT TO DAMAGE THE LUSTRE FINISH OR ALTER THEIR MECHANICAL PROPERTIES. USING SILICONE-BASED WAX CAN DAMAGE THE PAINTED SURFACES, DEPENDING ON THE VEHICLE COLOUR (SATIN COLOURS). FOR FURTHER INFORMATION ON THIS MATTER, CONTACT AN AUTHORISED SERVICE CENTRE.

### STARTING FAILURE

|                           |   |
|---------------------------|---|
| Emergency switch in «OFF» | Set the switch back to « <b>ON</b> »  |
| Fuse blown                | Replace the blown fuse and have the vehicle checked by an <b>Authorised Service Centre.</b> |

### IGNITION PROBLEMS

|                   |  |
|-------------------|--|
| Faulty spark plug | Contact an <b>Authorised Service Centre.</b> |
|-------------------|--|



|   |   |
|---|---|
| Faulty ignition / injection control unit. | Contact an <b>Authorised Service Centre</b> . |
|---|---|

|   |   |
|---|---|
| Faulty coil. Due to the presence of high voltage, this check should only be carried out by an expert. | Contact an <b>Authorised Service Centre</b> . |
|---|---|

### **LACK OF COMPRESSION**

|                   |                                 |
|-------------------|---------------------------------|
| Loose spark plug. | Screw in the spark plug tightly |
|-------------------|---------------------------------|

|   |   |
|---|---|
| Cylinder head loose, piston gas rings worn. | Contact an <b>Authorised Service Centre</b> . |
|---|---|

|             |   |
|-------------|---|
| Valve stuck | Contact an <b>Authorised Service Centre</b> . |
|-------------|---|

### **HIGH CONSUMPTION AND LOW PERFORMANCE**

|                              |   |
|------------------------------|---|
| Air filter blocked or dirty. | Clean with water and shampoo and impregnate with petrol and specific oil («Air filter removal» section) |
|------------------------------|---|

### **INSUFFICIENT BRAKING**

|   |   |
|---|---|
| Greasy disc. Worn pads. Faulty braking system. Presence of air in the front and rear brake circuit. | Contact an <b>Authorised Service Centre</b> . |
|---|---|

### **INEFFICIENT SUSPENSIONS**

|  |   |
|--|---|
| Shock absorber fault, oil leak, end buffers damaged; shock absorber preloading incorrectly set | Contact an <b>Authorised Service Centre</b> . |
|--|---|

### **AUTOMATIC TRANSMISSION PROBLEMS**

|  |   |
|--|---|
| Variator rollers and/or driving belt damaged | Contact an <b>Authorised Service Centre</b> . |
|--|---|

### **STAND DOES NOT RETURN TO POSITION**

|                  |                  |
|------------------|------------------|
| Presence of dirt | Clean and grease |
|------------------|------------------|

# MP3 LT 400 i.e.



**PIAGGIO®**



**Chap. 04**  
**Technical data**

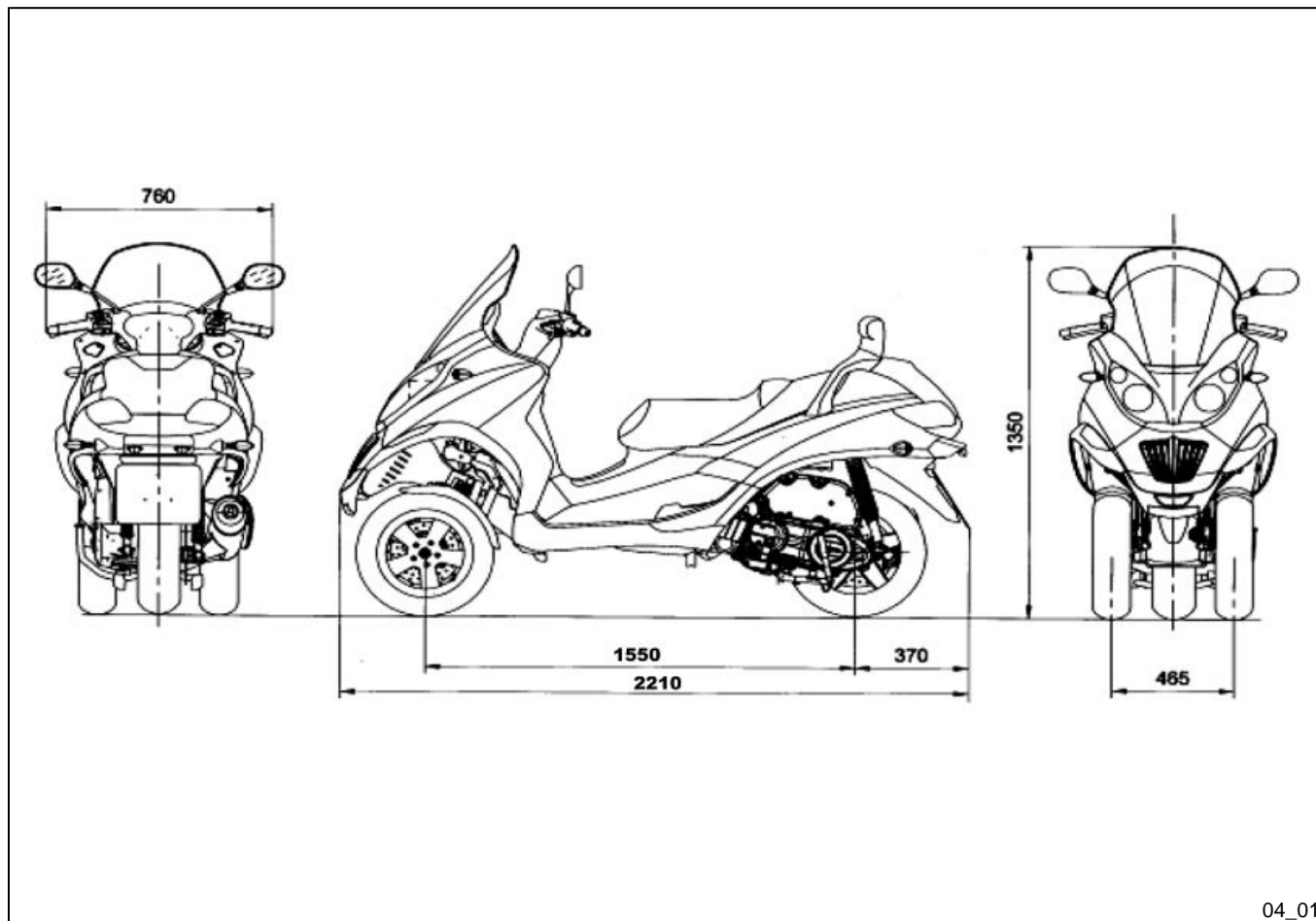

**ENGINE TECHNICAL DATA**

|                      |   |
|----------------------|---|
| Type                 | Single-cylinder, 4-stroke   |
| Cubic capacity       | 399 cm <sup>3</sup>   |
| Bore x stroke        | 85.8 X 69 mm  |
| Compression ratio    | 10.6 ± 0.5 : 1  |
| Engine idle speed    | 1,500 ± 100 rpm   |
| Timing system        | Four valves, single overhead camshaft, chain-driven.  |
| Valve clearance      | Inlet: 0.15 mm<br>Outlet: 0.15 mm   |
| MAX Power            | 24 kW at 7,250 rpm  |
| MAX torque           | 38 Nm at 5,250 rpm  |
| Transmission         | Automatic expandable pulley variator with torque server, V belt, automatic clutch.                          |
| FINAL REDUCTION GEAR | Gear reduction unit in oil bath.  |
| Lubrication          | Engine lubrication with trochoidal pump (inside the crankcase), oil filter and pressure adjustment by-pass. |
| Cooling              | Forced coolant circulation system.  |
| Start-up             | Electric  |
| Ignition             | Electronic, inductive, high efficiency ignition, integrated with  |

|                        |  |
|------------------------|--|
|                        | the injection system, with variable advance and separate HV coil.          |
| Ignition advance       | Three-dimensional map managed by control unit                              |
| Spark plug             | CHAMPION RG 6 YC   |
| Alternative spark plug | NGK CR7EKB   |
| Fuel supply            | Electronic injection with electric fuel pump.                              |
| Fuel                   | Unleaded petrol (95 RON)   |
| Muffler                | Absorption-type exhaust muffler with catalytic converter and lambda probe. |
| Emission regulations   | EURO 3   |

### **VEHICLE TECHNICAL DATA**

|                  |  |
|------------------|--|
| Chassis          | Tubular and sheet steel  |
| Front suspension | The tilt mechanism is composed of an articulated parallelogram suspension with die-cast aluminium control arms and two side headstocks plus shock absorbers with hydraulic locking system. |
| Rear suspension  | Two double-acting shock absorbers, adjustable to four positions at preloading.   |

|                         |   |
|-------------------------|---|
| Front brake             | Ø 240 mm double disc brake with hydraulic control activated by the handlebar right-hand lever.                    |
| Rear brake              | Ø 240 mm disc brake, with hydraulic control activated by the handlebar left-hand lever.                           |
| Integral braking system | The system operates all three discs simultaneously and is controlled hydraulically via the pedal on the footrest. |
| Wheel rim type          | Light alloy rims.   |
| Front rim               | 12" x 3.00  |
| Rear rim                | 14" x 4.50  |
| Front tyre              | Tubeless, 120/70-12" 51S or 51P   |
| Rear tyre               | Tubeless 120/70-14" 68S or 68P  |
| Front tyre pressure     | 1.6 bar   |
| Rear tyre pressure      | 2.5 bar   |
| Kerb weight             | 253 ± 8 kg  |
| Maximum weight allowed  | 445 kg  |
| Battery                 | 12V/14 Ah, sealed battery   |

### **CAPACITY**

|                  |                     |
|------------------|---------------------|
| Engine oil       | 1.7 l               |
| Transmission oil | 250 cm <sup>3</sup> |

|                      |                            |
|----------------------|----------------------------|
| Cooling system fluid | ~ 1.8 l                    |
| Fuel tank (reserve)  | approx. 12 l (approx. 2 l) |

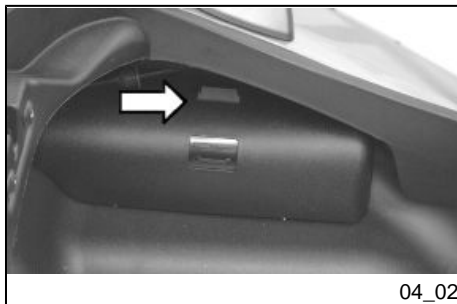

### Kit equipment (04\_02)

One box-spanner; one lever for box-spanner; one twin screwdriver; one 13-mm flat wrench; one special spanner for adjusting the rear shock absorbers one plastic gripper for removing the fuses.

The tools are stored under the saddle in the compartment provided. To open it, release the catch shown in the figure.

04\_02



# MP3 LT 400 i.e.



**PIAGGIO®**



**Chap. 05  
Spare parts and  
accessories**



## Warnings (05\_01)

### WARNING



TO PREVENT ACCIDENTS AND TO GUARANTEE PROPER STABILITY, PERFORMANCE AND SAFETY, RIDE THE VEHICLE VERY CAREFULLY WHEN IT IS FITTED WITH ACCESSORIES OR WITH UNUSUAL LOADS.

### WARNING



IT IS ALSO RECOMMENDED THAT ORIGINAL PIAGGIO SPARE PARTS BE USED, AS THESE ARE THE ONLY ONES OFFERING YOU THE SAME QUALITY GUARANTEE AS THOSE INITIALLY FITTED ON THE SCOOTER. THE USE OF NON-ORIGINAL SPARE PARTS RENDERS THE WARRANTY VOID.

### WARNING



PIAGGIO MARKETS ITS OWN LINE OF ACCESSORIES THAT ARE RECOGNISED AND GUARANTEED FOR USE. IT IS THEREFORE ESSENTIAL TO CONTACT AN AUTHORISED DEALER OR SERVICE CENTRE IN ORDER TO CHOOSE AND FIT ACCESSORIES CORRECTLY. THE USE OF NON-ORIGINAL ACCESSORIES MAY AFFECT THE STABILITY AND OPERATION OF YOUR VEHICLE AND REDUCE SAFETY LEVELS WITH POTENTIAL RISKS FOR THE RIDER.

### WARNING



NEVER RIDE THE VEHICLE WITH ADDED ACCESSORIES (CASE AND/OR WINDSHIELD) FASTER THAN 120 KM/H. WITHOUT THESE ACCESSORIES THE VEHICLE MAY BE DRIVEN AT A HIGHER SPEED WITHIN THE LEGAL LIMITS. IF

**THERE ARE NOT-PIAGGO ACCESSORIES FITTED, OR AN ABNORMAL LOAD, OR IF THE VEHICLE IS NOT IN A GENERALLY GOOD CONDITION, OR WHENEVER WEATHER CONDITIONS DEMAND IT, SPEED SHOULD BE FURTHER REDUCED.**

**WARNING**



**BE EXTREMELY CAREFUL WHEN INSTALLING AND REMOVING THE MECHANICAL ANTITHEFT DEVICE ON THE VEHICLE (U-SHAPED PADLOCK, DISC BLOCK, ETC.).**

**MAINLY NEAR THE BRAKE PIPES, TRANSMISSIONS AND/OR ELECTRIC CABLES, AN INCORRECT INSTALLATION OR REMOVAL OF THE ANTITHEFT DEVICE AS WELL AS LEAVING IT ON BEFORE STARTING THE VEHICLE CAN SERIOUSLY DAMAGE ITS COMPONENTS, COMPROMISE THE CORRECT FUNCTIONING OF THE VEHICLE AND USERS' SAFETY.**



# MP3 LT 400 i.e.



**PIAGGIO®**



**Chap. 06  
Programmed  
maintenance**



06\_01

## Scheduled maintenance table (06\_01)

Adequate maintenance is fundamental to ensure long-lasting, optimum operation and performance of your vehicle.

To this end, a series of checks and maintenance operations (at the owner's expense) have been suggested, which are included in the summary table on the following page. Any minor faults should be reported without delay to an **Authorised Service Centre or Dealer** without waiting until the next scheduled service to solve it.

All scheduled maintenance services must be carried out at the specified intervals, even if the stated mileage has not yet been reached. Punctual scooter servicing is essential to ensure your warranty remains valid. For any further information concerning Warranty procedures and 'Scheduled Maintenance', please refer to the 'Warranty Booklet'.

### SCHEDULED MAINTENANCE TABLE

| km x 1,000                         | 1 | 5 | 10 | 15 | 20 | 25 | 30 | 35 | 40 | 45 | 50 | 55 | 60 | 65 | 70 | 75 | 80 |
|------------------------------------|---|---|----|----|----|----|----|----|----|----|----|----|----|----|----|----|----|
| Safety locks                       | I |   | I  |    |    |    | I  |    |    |    | I  |    |    |    | I  |    |    |
| Throttle control                   | A |   | A  |    | A  |    | A  |    | A  |    | A  |    | A  |    | A  |    | A  |
| Engine oil filter                  | R |   | R  |    | R  |    | R  |    | R  |    | R  |    | R  |    | R  |    | R  |
| Electrical system and battery      | I |   | I  |    |    |    | I  |    |    |    | I  |    |    |    | I  |    |    |
| Coolant level *                    | I |   | I  |    | I  |    | I  |    | I  |    | I  |    | I  |    | I  |    | I  |
| Brake oil level*                   | I |   | I  |    | I  |    | I  |    | I  |    | I  |    | I  |    | I  |    | I  |
| Engine oil                         | R | I | R  | I  | R  | I  | R  | I  | R  | I  | R  | I  | R  | I  | R  | I  | R  |
| Brake pads                         | I | I | I  | I  | I  | I  | I  | I  | I  | I  | I  | I  | I  | I  | I  | I  | I  |
| Tyre pressure and wear             | I |   | I  |    | I  |    | I  |    | I  |    | I  |    | I  |    | I  |    | I  |
| Vehicle and brake test - test ride | I |   | I  |    | I  |    | I  |    | I  |    | I  |    | I  |    | I  |    | I  |

| km x 1,000   | 1 | 5 | 10 | 15 | 20 | 25 | 30 | 35 | 40 | 45 | 50 | 55 | 60 | 65 | 70 | 75 | 80 |
|--|---|---|----|----|----|----|----|----|----|----|----|----|----|----|----|----|----|
| Hub oil  | R |   | I  |    | R  |    |    |    | R  |    | I  |    | R  |    | I  |    | R  |
| Steering   | I |   | I  |    | I  |    | I  |    | I  |    | I  |    | I  |    | I  |    | I  |
| Parking control unit software upgrading (if available) | I | I | I  | I  | I  | I  | I  | I  | I  | I  | I  | I  | I  | I  | I  | I  | I  |
| Centre stand   |   | L | L  | L  | L  | L  | L  | L  | L  | L  | L  | L  | L  | L  | L  | L  | L  |
| Driving belt   |   |   | R  |    | R  |    | R  |    | R  |    | R  |    | R  |    | R  |    | R  |
| Air filter   |   |   | C  |    | I  |    | C  |    | I  |    | C  |    | I  |    | C  |    | I  |
| Sliding blocks / variable speed rollers                |   |   | R  |    | R  |    | R  |    | R  |    | R  |    | R  |    | R  |    | R  |
| Suspensions  |   |   | I  |    | I  |    | I  |    | I  |    | I  |    | I  |    | I  |    | I  |
| Spark plugs  |   |   | R  |    | R  |    | R  |    | R  |    | R  |    | R  |    | R  |    | R  |
| Tilt locking caliper control cable                     |   |   | A  |    | A  |    | A  |    | A  |    | A  |    | A  |    | A  |    | A  |
| Valve clearance  |   |   |    |    | I  |    |    |    | I  |    |    |    | I  |    |    |    | I  |
| Electrical system and battery                          |   |   |    |    | I  |    |    |    | I  |    |    |    | I  |    |    |    |    |

*I: CHECK AND CLEAN, ADJUST, LUBRICATE OR REPLACE IF NECESSARY.*

*C: CLEAN, R: REPLACE, A: ADJUST, L: LUBRICATE*

*\* Replace every 2 years*

### **RECOMMENDED PRODUCTS TABLE**

| Product           | Description  | Specifications   |
|-------------------|--------------|--|
| AGIP ROTRA 80W-90 | Rear hub oil | SAE 80W/90 Oil that exceeds the requirements of API GL3 specifications |

| <b>Product</b>         | <b>Description</b>  | <b>Specifications</b>  |
|------------------------|---|--|
| AGIP CITY HI TEC 4T    | Oil to lubricate flexible transmissions (throttle control)  | Oil for 4-stroke engines                                       |
| AGIP FILTER OIL        | Oil for air filter sponge                                   | Mineral oil with specific additives for increased adhesiveness |
| AGIP GP 330            | Calcium complex soap-based grease with NLGI 2; ISO-L-XBCIB2 | Grease (brake control levers, throttle grip)                   |
| AGIP CITY HI TEC 4T    | Engine oil  | SAE 5W-40, API SL, ACEA A3, JASO MA Synthetic oil              |
| AGIP BRAKE 4           | Brake fluid   | FMVSS DOT 4 Synthetic fluid                                    |
| AGIP PERMANENT SPEZIAL | coolant   | Monoethylene glycol-based antifreeze fluid, CUNA NC 956-16     |



# TABLE OF CONTENTS

## **A**

Air filter: 64

## **B**

Battery: 69

Brake: 66, 84

## **C**

Clock: 12

## **D**

Disc brake: 84

Display: 13

## **E**

Engine oil: 56–58

Engine stop: 18

## **F**

Fuel: 26

Fuses: 70

## **H**

Headlight: 79

Horn: 16

Hub oil: 59

## **I**

Identification: 30

Immobilizer: 19, 22

Instrument panel: 10

## **K**

Key switch: 14

Keys: 19

## **L**

Light switch: 17

## **M**

Maintenance: 13, 55, 101,  
102

Mirrors: 84

## **S**

Saddle: 24, 26, 27, 29

Scheduled maintenance:  
102

Shock absorbers: 38

Spark plug: 62

Stand: 45

Start-up: 18

## **T**

Tank: 26

Technical Data: 91

Top box: 30

Transmission: 45

Turn indicators: 82

Tyre pressure: 37

Tyres: 61



The descriptions and illustrations given in this publication are not binding. While the basic specifications as described and illustrated in this manual remain unchanged, PIAGGIO-GILERA reserves the right, at any time and without being required to update this publication beforehand, to make any changes to components, parts or accessories, which it considers necessary to improve the product or which are required for manufacturing or construction reasons.

Not all versions/models shown in this publication are available in all countries. The availability of each model should be checked at the official Piaggio sales network.

"© Copyright 2008 - PIAGGIO & C. S.p.A. Pontedera. All rights reserved. Reproduction of this publication in whole or in part is prohibited."

PIAGGIO & C. S.p.A. - After-Sales

V.le Rinaldo Piaggio, 23 - 56025 PONTEDERA (Pi)