



WORKSHOP MANUAL

633574



Beverly 250 USA



WORKSHOP MANUAL

Beverly 250 USA

The descriptions and illustrations given in this publication are not binding. While the basic features as described and illustrated in this manual remain unchanged, PIAGGIO - GILERA reserves the right, at any time and without being required to update this publication beforehand, to make any changes to components, parts or accessory supplies, which it considers necessary to improve the product or which are required for manufacturing or construction reasons.

Not all versions shown in this publication are available in all Countries. The availability of individual versions should be confirmed with the official Piaggio sales network.

"© Copyright 2007 - PIAGGIO & C. S.p.A. Pontedera. All rights reserved. Reproduction of this publication in whole or in part is prohibited."

PIAGGIO & C. S.p.A. - After-Sales
V.le Rinaldo Piaggio, 23 - 56025 PONTEDERA (Pi)

WORKSHOP MANUAL

Beverly 250 USA

This workshop manual has been drawn up by Piaggio & C. Spa to be used by the workshops of Piaggio-Gilera dealers. This manual is addressed to Piaggio service mechanics who are supposed to have a basic knowledge of mechanics principles and of vehicle fixing techniques and procedures. Any important changes made to the vehicles or to specific fixing operations will be promptly reported by updates to this manual. Nevertheless, no fixing work can be satisfactory if the necessary equipment and tools are unavailable. It is therefore advisable to read the sections of this manual relating to specific tools, along with the specific tool catalogue.

N.B. Provides key information to make the procedure easier to understand and carry out.

CAUTION Refers to specific procedures to carry out for preventing damages to the vehicle.

WARNING Refers to specific procedures to carry out to prevent injuries to the repairer.



Personal safety Failure to completely observe these instructions will result in serious risk of personal injury.



Safeguarding the environment Sections marked with this symbol indicate the correct use of the vehicle to prevent damaging the environment.



Vehicle intactness The incomplete or non-observance of these regulations leads to the risk of serious damage to the vehicle and sometimes even the invalidity of the guarantee.



INDEX OF TOPICS

CHARACTERISTICS

CHAR

TOOLING

TOOL

MAINTENANCE

MAIN

TROUBLESHOOTING

TROUBL

ELECTRICAL SYSTEM

ELE SYS

ENGINE FROM VEHICLE

ENG VE

ENGINE

ENG

SUSPENSIONS

SUSP

BRAKING SYSTEM

BRAK SYS

COOLING SYSTEM

COOL SYS

CHASSIS

CHAS

PRE-DELIVERY

PRE DE

TIME

TIME

INDEX OF TOPICS

CHARACTERISTICS

CHAR

Rules

This section describes general safety rules for any maintenance operations performed on the vehicle.

Safety rules

- If work can only be done on the vehicle with the engine running, make sure that the premises are well-ventilated, using special extractors if necessary; never let the engine run in an enclosed area. Exhaust fumes are toxic.
 - The battery electrolyte contains sulphuric acid. Protect your eyes, clothes and skin. Sulphuric acid is highly corrosive; in the event of contact with your eyes or skin, rinse thoroughly with abundant water and seek immediate medical attention.
 - The battery produces hydrogen, a gas that can be highly explosive. Do not smoke and avoid sparks or flames near the battery, especially when charging it.
 - Fuel is highly flammable and it can be explosive given some conditions. Do not smoke in the working area, and avoid open flames or sparks.
 - Clean the brake pads in a well-ventilated area, directing the jet of compressed air in such a way that you do not breathe in the dust produced by the wear of the friction material. Even though the latter contains no asbestos, inhaling dust is harmful.
-

Maintenance rules

- Use original PIAGGIO spare parts and lubricants recommended by the Manufacturer. Non-original or non-conforming spares may damage the vehicle.
 - Use only the appropriate tools designed for this vehicle.
 - Always use new gaskets, sealing rings and split pins upon refitting.
 - After removal, clean the components using non-flammable or low flash-point solvent. Lubricate all the work surfaces except the tapered couplings before refitting.
 - After refitting, make sure that all the components have been installed correctly and work properly.
 - For removal, overhaul and refit operations use only tools with metric measures. Metric bolts, nuts and screws are not interchangeable with coupling members with English measurement. Using unsuitable coupling members and tools may damage the scooter.
 - When carrying out maintenance operations on the vehicle that involve the electrical system, make sure the electric connections have been made properly, particularly the ground and battery connections.
-

Vehicle identification

VEHICLE IDENTIFICATION

Specification	Desc./Quantity
Chassis prefix	ZAPM 289 L36S
Engine prefix	M285M÷1001

Dimensions and mass

WEIGHTS AND DIMENSIONS

Specification	Desc./Quantity
Kerb weight in running order	149 kg
Width (over mirrors)	837 mm
Length	2100 mm
Wheelbase	1455 mm
Saddle height	785 mm



Engine

ENGINE

Specification	Desc./Quantity
Engine type	Single-cylinder, four-stroke, four-valve, liquid-cooled.
Timing system	Single overhead camshaft driven by chain on left side, three-arm rockers with threaded adjuster.
Bore x stroke	72 x 60 mm
Cubic capacity	244.29 cm ³
Compression ratio	10.5 ÷ 11.5 : 1
Carburettor Keihin	CVEK-30
Carburatore Walbro	WVF-7S*
Idle speed	1650 ± 50 rpm
CO adjustment	3,8 ± 07%
Air filter	Sponge-type damped with a 50% Selenia Air Filter Oil - 50% unleaded petrol mixture
Starter System	Electric starter motor
Lubrication	Engine lubrication with lobe pump (inside crankcase) controlled by a chain with double filter: mesh and paper.
Fuel supply	with unleaded petrol; carburettor and vacuum pump.
Maximum power (to the crankshaft) 125	11 Kw (15CV) at 9750 rpm.
Top speed	124 Km/h

*The identification marking may change whenever the carburettor is updated

Transmission

TRASMISSION

Specification	Desc./Quantity
Transmission	With automatic expandable pulley variator with torque server, V belt, self-ventilating automatic centrifugal dry clutch, gear reduction unit and transmission housing with forced air circulation cooling.

Capacities

CAPACITIES

Specification	Desc./Quantity
Engine oil	~ 1200 cc
Petrol tank	approx. 10 l (including reserve approx. 2.5 l)
Rear hub oil	250 cc

Electrical system

ELECTRICAL SYSTEM

Specification	Desc./Quantity
Ignition type	Electronic capacitive discharge ignition (CDI) and variable advance, with separate HV coil.
Ignition advance (before T.D.C)	10° ± 1 at 2000 rpm. 28° ± 1 at 6500 rpm.
Spark plug	CHAMPION RG4HC
Battery	12V-12Ah
Fuses	N° 2 15A, N°1 10A, N° 2 7,5A, N° 3 4A
Generator	alternating current

Frame and suspensions

FRAME AND SUSPENSIONS

Specification	Desc./Quantity
Chassis type	Welded tubular steel chassis with stamped sheet reinforcements
Front suspension	Hydraulic telescopic fork with advanced wheel pin and Ø 35 mm stem
Front fork max. stroke	104 mm
Rear suspension	Engine with swinging fork attached to frame by means of an arm with 2 degrees of freedom Pair of double-acting hydraulic shock absorbers and coaxial springs with preloading adjustment in four positions.
Rear shock absorber max. travel	95.5 mm

Brakes

BRAKES

Specification	Desc./Quantity
Front brake	Disc brake, diameter 260 mm and floating calliper with twin plungers and hydraulic control (lever on the far right of the handlebar)
Rear brake	Disc brake, diameter 260 mm and calliper with two counteracting plungers and hydraulic control (lever on the far left of the handlebar)

Wheels and tyres

WHEELS AND TYRES

Specification	Desc./Quantity
Front wheel rim	Light alloy, 3.00 x 16"
Rear wheel rim	Light alloy, 3.50 x 16"
Front tyre	110/70-16" M/C 52P Tubeless
Rear tyre	140/70-16" M/C 65P Tubeless
Front wheel tyre pressure (when cold)	2.1 bar
Rear wheel tyre pressure (when cold)	2.3 bar
Rear wheel tyre pressure (with driver and passenger) (when cold)	2.5 bar

N.B.

CHECK AND ADJUST TYRE PRESSURE WITH TYRES AT AMBIENT TEMPERATURE. REGULATE PRESSURE ACCORDING TO THE WEIGHT OF THE RIDER AND ACCESSORIES

Secondary air

The working principle of the SAS for Quasar 250 cc Euro 2 engines is entirely similar to the SAS employed on 2-stroke engines. The main differences are the following:

Secondary air enters directly into the exhaust duct on the cylinder head, instead of entering through the exhaust pipe as in two-stroke engines.

The reed valve found on 2-stroke engines is here replaced by a membrane.

Unit «A», shown in the figure, is provided with a cut-off connected to the vacuum inlet on the intake manifold to shut air inlet during deceleration, so to prevent detonations in the silencer. Air is sucked in through hole «B» and flows inside the duct into

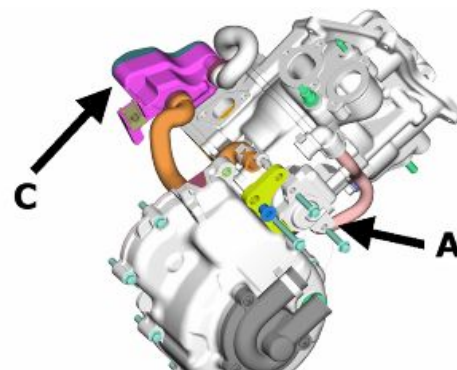

air-box «C» where it is filtered by filtering element «D».

The filtered air now enters membrane device «A», through duct «E» and is then guided towards the head.

Flowing through pipe «F», flanged to the head, secondary air reaches the exhaust duct thus providing oxygen addition to the unburnt gases just before they enter the catalytic converter.

The efficiency of the catalyzing process is therefore increased.

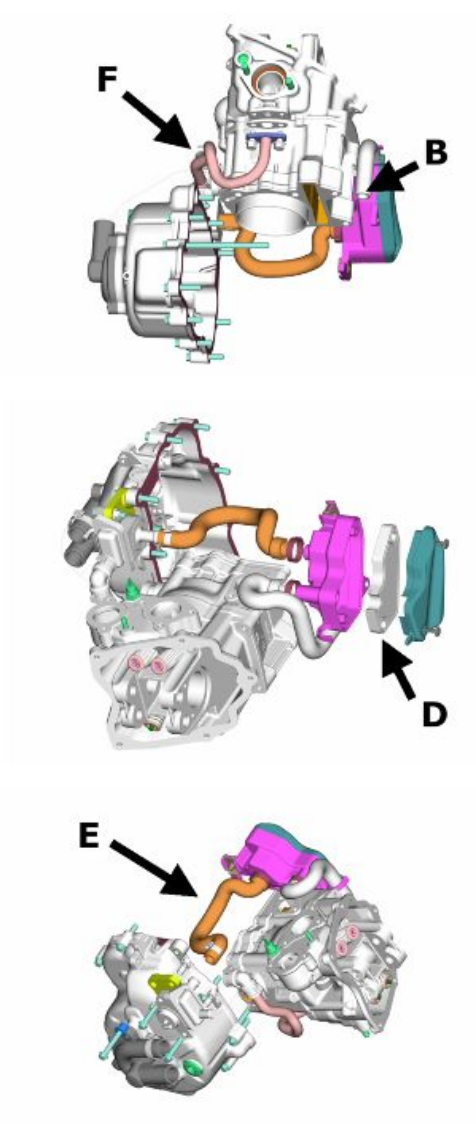

Carburettor

250cc Version

Keihin

KEIHIN CARBURETTOR

Specification	Desc./Quantity
Depression type	CVEK30
Printing on the body	CVK
CUT-OFF device	Present
Max jet	100
Minimum jet	38
Max. air jet	70
Minimum air jet	115

Specification	Desc./Quantity
Idle mixture adjustment screw initial opening	2½ ± ¼
Conical pin	Ø 2,530
Diffuser nozzle	Ø 2.8
Starter air jet	Ø 1,5
Starter jet	42
Starter device resistance	~ 20 Ω
Venturi choke	Ø 29
Throttle valve	Ø 30,5
Choke maximum cone	Ø 47

Walbro

WALBRO CARBURETTOR

Specification	Desc./Quantity
Depression type	WVF-7S*
Printing on the body	7S
CUT-OFF device	Present
Max. jet	118
Minimum jet	34
Max. air jet	150
Minimum air jet	31
Throttle valve spring	120 g
Idle mixture adjustment screw initial opening	3 ± ½
Conical pin	465
Conical pin top notches	3
Diffuser nozzle	Ø 2.7
Gasoline inlet hole	Ø 1.5
Starter air jet	200
Starter diffuser jet	130
Starter jet	50
Starter pin diameter	Ø 1,78
Starter device resistance	~ 40 Ω
Venturi diffuser	Ø 29 (30.3x27)
Throttle valve	Ø 33
Choke maximum cone	Ø 48,0

*The identification marking may change whenever the carburettor is updated

Tightening Torques

STEERING

Name	Torque in Nm
Upper steering ring nut	30 ÷ 36
Steering lower ring nut	10 ÷ 13 then loosen by 90°
Handlebar fixing screw (*)	45 ÷ 50
Fixing screws for handlebar control assembly U-bolts	7 ÷ 10

FRAME ASSEMBLY

Name	Torque in Nm
Engine-swinging arm bolt	64 - 72
Chassis-swinging arm pin nut	64 - 72
Spacer locking threaded bushing	13 ÷ 17
Spacer locking threaded bushing lock nut	90 ÷ 110
Frame arm-engine arm coupling pin nut	33 ÷ 41
Bolt of the Silent block support plate	64 - 72
Centre stand bolt	25 ÷ 30
Side stand fixing bolt	35 ÷ 40
Side stand switch screw	5 ÷ 7

FRONT SUSPENSION

Name	Torque in Nm
Fixing screw for pumping elements to lower fork plate	20 ÷ 25
Front wheel shaft	45 ÷ 50
Fork leg screw	6 ÷ 7
front mudguard to plate fixing screw	4.5 ÷ 7
Fixing screw for mudguard plate to fork	9 ÷ 11

FRONT BRAKE

Name	Torque in Nm
Brake fluid pump - hose fitting	16 ÷ 20
Brake fluid pipe-calliper fitting	16 ÷ 20
Calliper to fork tightening screw	20 ÷ 25
Disc tightening screw (°)	5 - 6
Oil bleed screw	12 - 16
Pad fastening pin	19.6 ÷ 24.5

REAR SUSPENSION

Name	Torque in Nm
Left lower shock absorber support bolt	20 ÷ 25
Upper shock absorber clamp	33 ÷ 41
Shock absorber lower clamp	33 ÷ 41
Rear wheel axle	104 ÷ 126
Fixing screw for wheel rim to hub	34 ÷ 38
Muffler support arm to engine screws (*)	20 ÷ 25

REAR BRAKE

Name	Torque in Nm
Brake fluid pump - hose fitting	16 ÷ 20
Brake fluid pipe-calliper fitting	16 ÷ 20
Flexible/ rigid oil pipe coupling	9 ÷ 11
Rear disc tightening bolt	11 ÷ 13
Oil bleed screw	12 - 16
Screw tightening calliper to the support	20 ÷ 25
Screw fixing rear brake calliper support to engine	20 ÷ 25
Pad fastening pin	20 ÷ 25

MUFFLER

Name	Torque in Nm
Screw fixing manifold to muffler	15.5 ÷ 18.5
Muffler heat guard fixing screw	5 - 6
Exhaust fumes inlet screw	22 ÷ 26
Screw fixing muffler support arm to crankcase	33 ÷ 41
Nuts fixing muffler to support arm	27 ÷ 30
Nut fixing muffler to cylinder head	16 ÷ 18

LUBRICATION

Name	Torque in Nm
Hub oil drainage plug	15 ÷ 17
Oil filter on crankcase fitting	27 ÷ 33
Engine oil drainage plug/mesh filter	24 ÷ 30
Oil filter	4 ÷ 6
Oil pump cover screws	0.7 ÷ 0.9
Screws fixing oil pump to the crankcase	5 - 6
Oil pump control crown screw	10 ÷ 14
Oil pump cover plate screws	4 ÷ 6
Oil sump screws	10 ÷ 14
Minimum oil pressure sensor	12 ÷ 14

CYLINDER HEAD

Name	Torque in Nm
Spark plug	12 ÷ 14
Nuts fixing head to cylinder (1) (^)	9 ÷ 11 + 180°
Head fixing side screws	11 ÷ 12
Starter ground screw	7 ÷ 8.5
Tappet set screw lock nut	6 ÷ 8
Timing chain tensioner slider screw	10 ÷ 14
Starter ground support screw	11 ÷ 15
Timing chain tensioner support screw	11 ÷ 13
Timing chain tensioner central screw	5 - 6
Camshaft retention plate screw	4 ÷ 6

TRANSMISSION

Name	Torque in Nm
Belt support roller screw	11 ÷ 13
Clutch unit nut on driven pulley	45 ÷ 50
Drive pulley nut	75 ÷ 83
Transmission cover screws	11 ÷ 13 Nm
Driven pulley shaft nut	54 ÷ 60
Rear hub cover screws	24 ÷ 27

FLYWHEEL

Name	Torque in Nm
Flywheel cover fixing screws	5 - 6
Stator assembly screws (°)	3 ÷ 4
Flywheel nut	94 - 102 Nm
Pick-Up clamping screws	3 ÷ 4
Screw fixing freewheel to flywheel	13 ÷ 15

CRANKCASE AND CRANKSHAFT

Name	Torque in Nm
Internal engine crankcase bulkhead (transmission-side half shaft) screws	4 ÷ 6
Engine-crankcase coupling screws	11 ÷ 13
Starter motor screws	11 ÷ 13
Crankcase timing system cover screws (°)	3.5 ÷ 4.5

COOLING

Name	Torque in Nm
Water pump rotor cover	3 ÷ 4
Screws for water pump rotor driving link	3 ÷ 4
Thermostat cover screws	3 ÷ 4
Bleed screw:	3

(°) Apply LOCTITE 242 medium-strength threadlock

(*) The two screws must be tightened to the prescribed torque after having done so with the rear wheel axle nut. Safety locks: see "Pre-delivery operations".

(^) Fasten the nuts in two crossed passes.

(1) Before fitting the nuts lubricate them with engine oil

Overhaul data

Assembly clearances

Cylinder - piston assy.

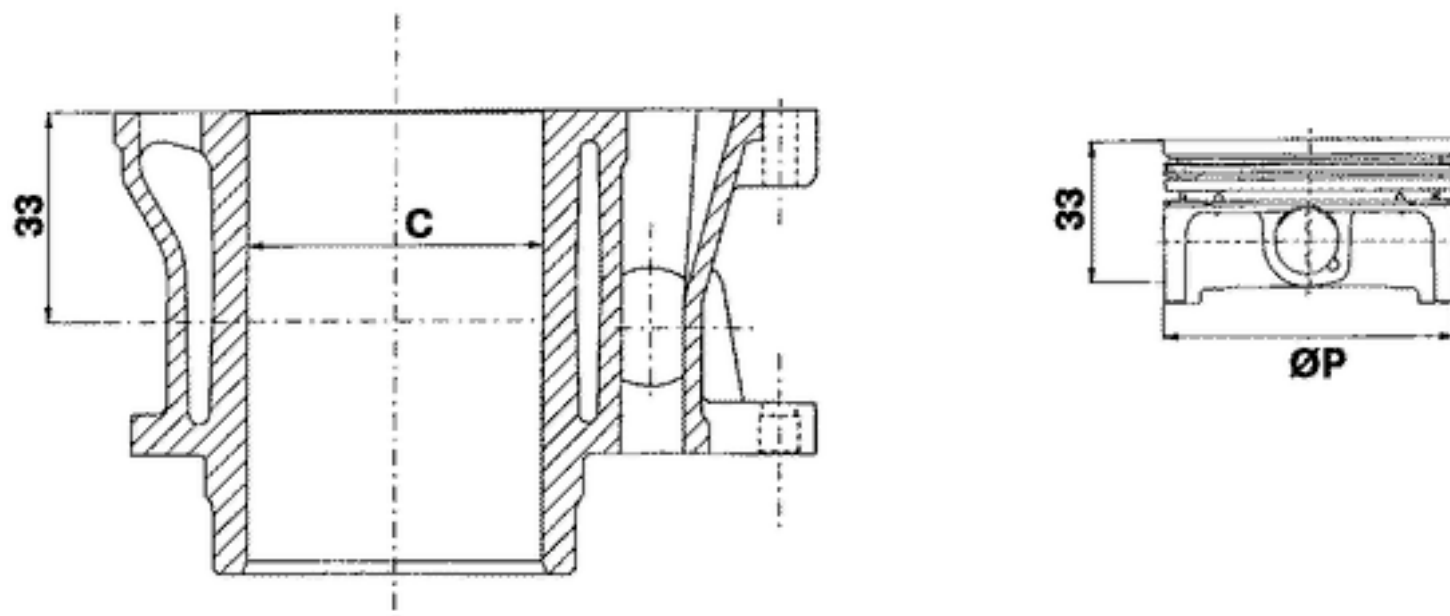

CATEGORIES COUPLING

Name	Initials	Cylinder	Piston	Play on fitting
Cylinder / piston	A	71.990 ÷ 71.997	71.953 ÷ 71.960	0.030 - 0.044
Cylinder / piston	B	71.997 ÷ 72.004	71.960 ÷ 71.967	0.030 - 0.044
Cylinder / piston	C	72.004 ÷ 72.011	71.967 ÷ 71.974	0.030 - 0.044
Cylinder / piston	D	72.011 ÷ 72.018	71.974 ÷ 71.981	0.030 - 0.044

Piston rings

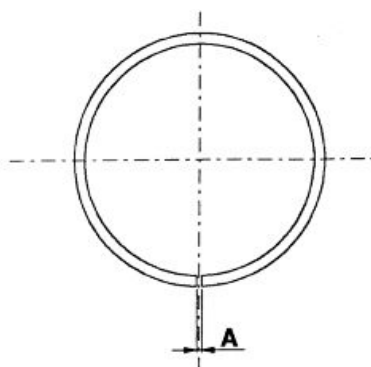

UPRATING TABLE MOTOR

Name	Description	Dimensions	Initials	Quantity
Compression ring		72 x 1.5	A	0.15 ÷ 0.30
Oil scraper ring		72 x 1	A	0.20 ÷ 0.40
Oil scraper ring		72 x 2.5	A	0.20 ÷ 0.40

Crankcase - crankshaft - connecting rod

CRANKCASE - CRANKSHAFT- CRANKSHAFT HALF-BEARINGS

Name	Description	Dimensions	Initials	Quantity
Crankshaft half-bearing			Type A - red	1.970 ÷ 1.973
Crankshaft half-bearing			Category B - blue	1.973 ÷ 1.976
Crankshaft half-bearing			Type C - yellow	1.976 ÷ 1.979
Crankshaft class 1 - Crankcase class 1			C - C	
Crankshaft class 1 - Crankcase class 2			B - B	
Crankshaft class 2 - Crankcase class 1			B - B	
Crankshaft class 2 - Crankcase class 2			A - A	
Crankshaft			Category 1	28.998 ÷ 29.004
Crankshaft			Class 2	29.004 ÷ 29.010

Name	Description	Dimensions	Initials	Quantity
Crankcase			Category 1	32.959 ÷ 32.965
Crankcase			Class 2	32.953 ÷ 32.959

Fitting clearance

Crankshaft/ crankcase axial clearance 0.15 - 0.40 mm (when cold)

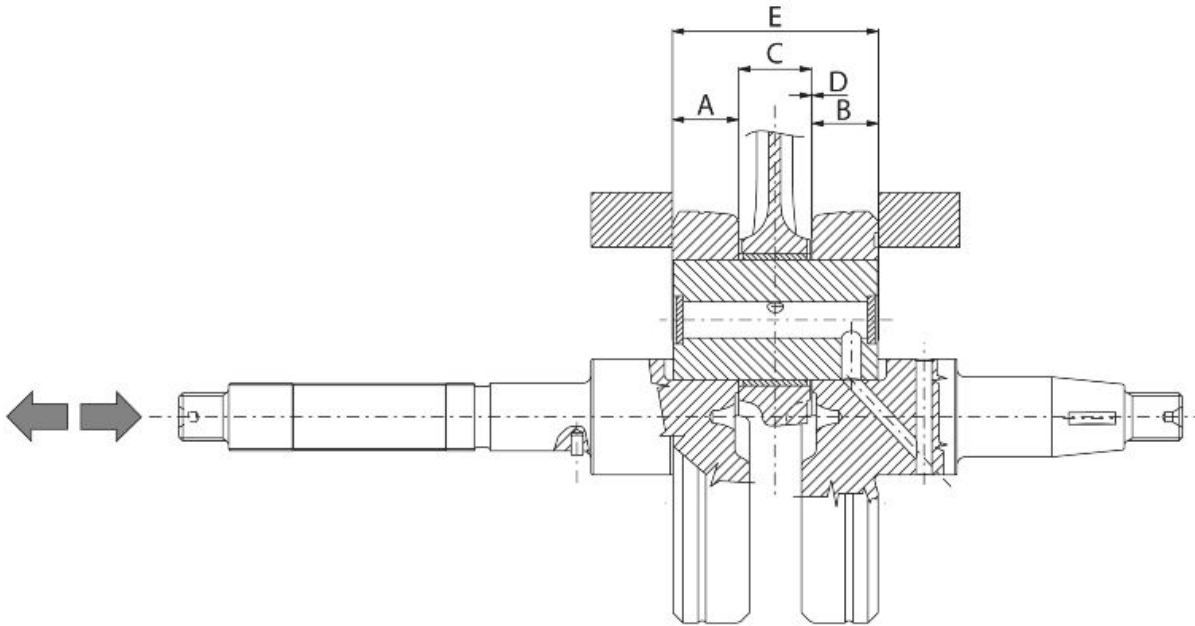

CRANKSHAFT/ CRANKCASE AXIAL CLEARANCE

Name	Description	Dimensions	Initials	Quantity
Half-shaft, transmission side		16.6 +0-0.05	A	D = 0.20 - 0.50
Flywheel-side half-shaft		16.6 +0-0.05	B	D = 0.20 - 0.50
Connecting rod		18 -0.10 -0.15	C	D = 0.20 - 0.50
Spacer tool		51.4 +0.05	E	D = 0.20 - 0.50

Slot packing system

Characteristic

Compression ratio

10.5 ÷ 11.5 : 1

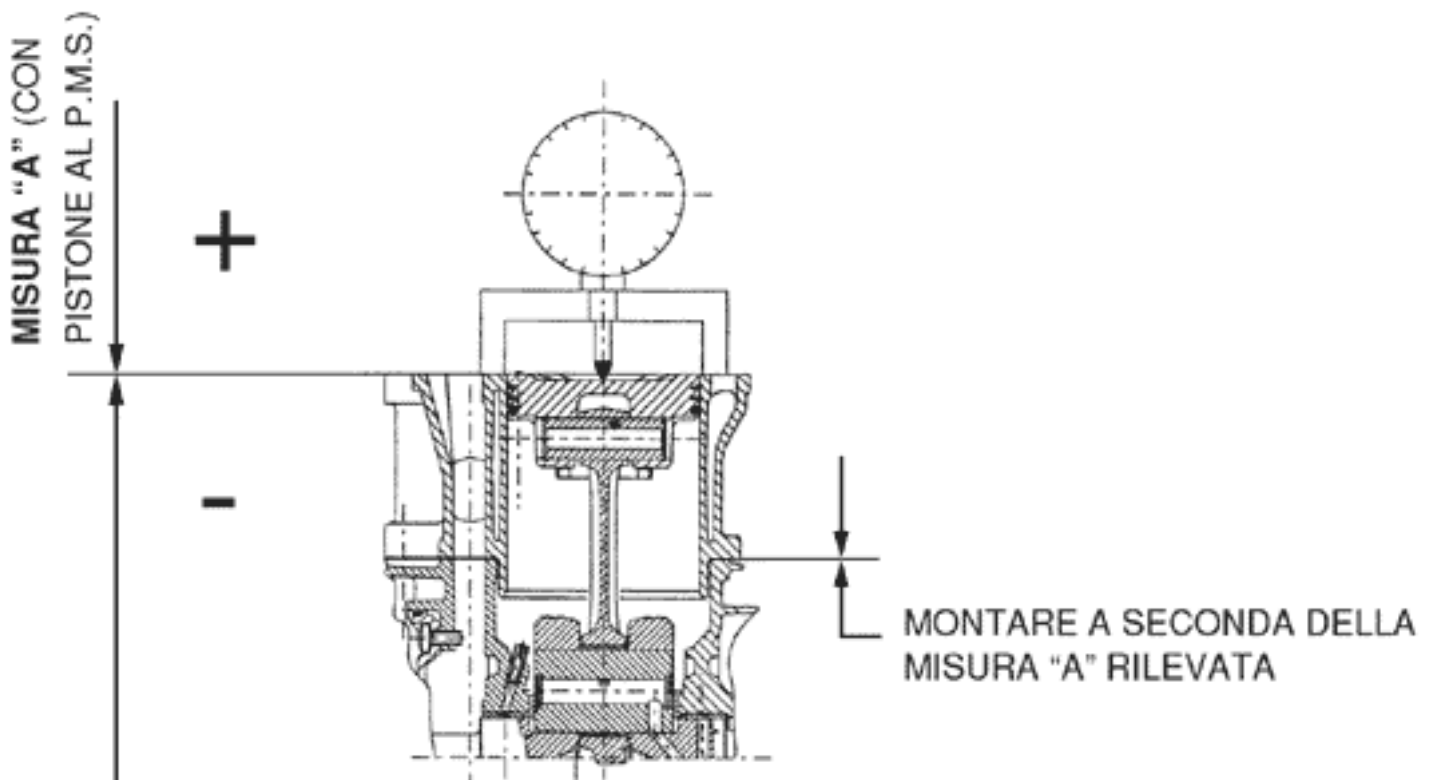

N.B. LA MISURA "A" DEVE ESSERE RILEVATA SENZA NESSUNA GUARNIZIONE MONTATA TRA CARTER E CILINDRO E DOPO AVER AZZERATO IL COMPARATORE, COMPLETO DI SUPPORTO, SU DI UN PIANO RETTIFICATO.

N.B.

MEASUREMENT "A" TO BE TAKEN IS A VALUE OF PISTON RE-ENTRY, IT INDICATES BY HOW MUCH THE PLANE FORMED BY THE PISTON CROWN FALLS BELOW THE PLANE FORMED BY THE TOP OF THE CYLINDER. THE FURTHER THE PISTON FALLS INSIDE THE CYLINDER, THE LESS THE BASE GASKET IS TO BE APPLIED (TO RECOVER THE COMPRESSION RATIO) AND VICE VERSA.

SHIMMING

Name	Measure A	Thickness
shimming	3.70 - 3.60	0.4 ± 0.05
shimming	3.60 - 3.40	0.6 ± 0.05
shimming	3.40 - 3.30	0.8 ± 0.05

Oversizes

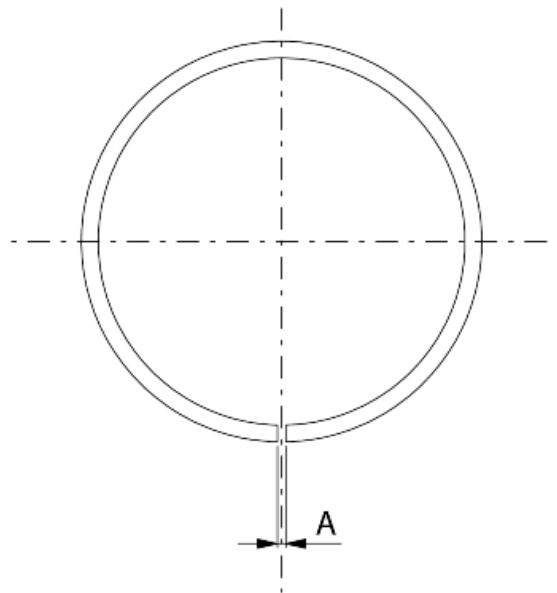

OVERSIZES

Name	Description	Dimensions	Initials	Quantity
Compression ring 1st oversize		57.2 x 1	A	0.15 ÷ 0.30
Oil scraper ring 1st Oversize		57.2 x 1	A	0.10 ÷ 0.30
Oil scraper ring 1st Oversize		57.2 x 2.5	A	0.15 ÷ 0.35
Compression ring 2nd Oversize		57.4 x 1	A	0.15 ÷ 0.30
Oil scraper ring 2nd Oversize		57.4 x 1	A	0.10 ÷ 0.30
Oil scraper ring 2nd Oversize		57.4 x 2.5	A	0.15 ÷ 0.35
Compression ring 3rd Oversize		57.6 x 1	A	0.15 ÷ 0.30
Oil scraper ring 3rd Oversize		57.6 x 1	A	
Oil scraper ring 3rd Oversize		57.6 x 2.5	A	0.15 ÷ 0.35

Products

RECOMMENDED PRODUCTS TABLE

Product	Description	Specifications
AGIP ROTRA 80W-90	Rear hub oil	SAE 80W/90 Oil that exceeds the requirements of API GL3 specifications





Product	Description	Specifications
AGIP GP 330	Grease for brake control levers, throttle, stand	White calcium complex soap-based spray grease with NLGI 2; ISO-L-XBCIB2
AGIP CITY HI TEC 4T	Oil to lubricate flexible transmissions (throttle control)	Oil for 4-stroke engines
AGIP BRAKE 4	Brake fluid	FMVSS DOT 4 Synthetic fluid
SPECIAL AGIP PERMANENT fluid	coolant	Monoethylene glycol-based anti-freeze fluid, CUNA NC 956-16
AGIP FILTER OIL	Oil for air filter sponge	Mineral oil with specific additives for increased adhesiveness
AUTOSOL METAL POLISH	Muffler cleaning paste	Specific product for cleaning and polishing stainless steel mufflers.
AGIP CITY HI TEC 4T	Engine oil	SAE 5W-40, API SL, ACEA A3, JASO MA Synthetic oil
AGIP GREASE SM 2	Grease for the tone wheel revolving ring	Soap-based lithium grease containing NLGI 2 Molybdenum disulphide; ISO-L-XBCHB2, DIN KF2K-20
AGIP GREASE PV2	Grease for the steering bearings, pin seats and swinging arm	White anhydrous-calcium based grease to protect roller bearings; temperature range between -20 C and +120 C; NLGI 2; ISO-L-XBCIB2.

INDEX OF TOPICS

TOOLING

TOOL

APPROPRIATE TOOLS

Stores code	Description	
020151Y	Air heater	
020331Y	Digital multimeter	
020648Y	Single battery charger	
001467Y014	Pliers to extract \varnothing 15-mm bearings	
020412Y	15 mm guide	

Stores code	Description
-------------	-------------

020335Y

Magnetic support for dial gauge



020565Y

Flywheel lock calliper spanner



020439Y

17 mm guide



020359Y







42x47-mm adaptor





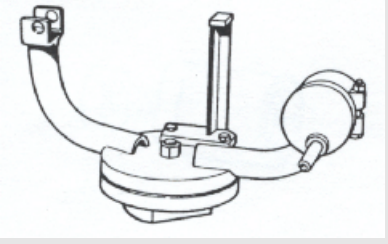



020363Y

20 mm guide

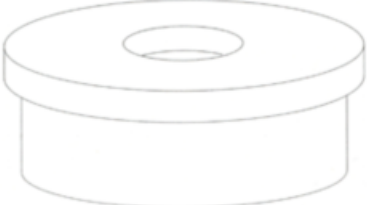

Stores code	Description	
020459Y	Punch for fitting bearing on steering tube	
020458Y	Puller for lower bearing on steering tube	
005095Y	Engine support	
008564Y	Flywheel extractor	
020434Y	Oil pressure control fitting	
020382Y011	adapter for valve removal tool	





Stores code	Description	
020424Y	Driven pulley roller casing fitting punch	
020431Y	Valve oil seal extractor	
020193Y	Oil pressure gauge	
020306Y	Punch for assembling valve seal rings	
020360Y	Adaptor 52 x 55 mm	
020364Y	25-mm guide	



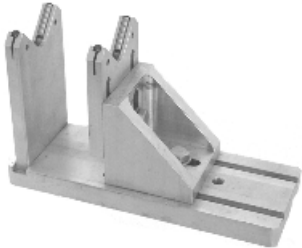

Stores code	Description	
020375Y	Adaptor 28 x 30 mm	
020376Y	Adaptor handle	
020444Y	Tool for fitting/ removing the driven pulley clutch	
020330Y	Stroboscopic light for timing control	
001467Y035	Belle for OD 47-mm bearings	
020368Y	driving pulley lock wrench	

Stores code	Description	
020319Y	Immobilizer check tester	
020287Y	Clamp to assemble piston on cylinder	
020263Y	Sheath for driven pulley fitting	
020262Y	Crankcase splitting strip	
020430Y	Pin lock fitting tool	
020428Y	Piston position check support	

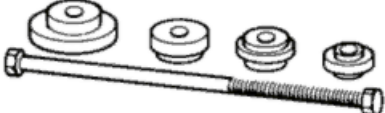
Stores code	Description	
020426Y	Piston fitting fork	
020425Y	Punch for flywheel-side oil seal	
020423Y	driven pulley lock wrench	
020414Y	28-mm guide	
020393Y	Piston fitting band	
020382Y	Valve cotters equipped with part 012 removal tool	

Stores code	Description	
020455Y	10-mm guide	
020442Y	Pulley lock wrench	
020440Y	Water pump service tool	
020329Y	MityVac vacuum-operated pump	
020357Y	32 x 35 mm adaptor	
020409Y	Multimeter adaptor - Peak voltage detection	

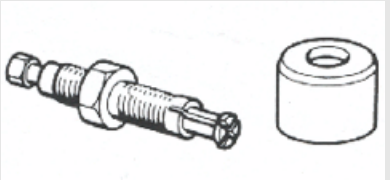
Stores code	Description	
020456Y	Ø 24 mm adaptor	
020332Y	Digital rev counter	
020074Y	Support base for checking crankshaft alignment	
020055Y	Wrench for steering tube ring nut	
002465Y	Pliers for circlips	
001330Y	Tool for fitting steering seats	

Stores code	Description	
020454Y	Tool for fitting piston pin stops (200 - 250)	
020622Y	Transmission-side oil guard punch	
020444Y011	adapter ring	
020444Y009	46x55 Wrench	
001467Y	Extractor for bearings for holes	
001467Y013	Pliers to extract ø 15-mm bearings	

Stores code	Description	
020444Y010	adapter ring	

020244Y 15 mm diameter punch



020115Y	Ø 18 punch	
---------	------------	--

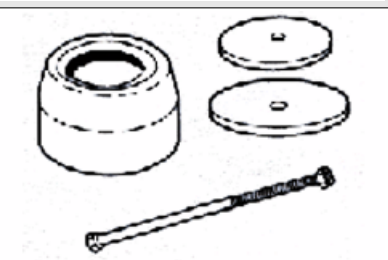

020271Y Tool for removing-fitting silent bloc



020627Y	Flywheel lock wrench	
---------	----------------------	---

020467Y Flywheel extractor



Stores code	Description	
020626Y	Driving pulley lock wrench	
020628Y	Water pump service kit	

INDEX OF TOPICS

MAINTENANCE

MAIN

Maintenance chart
EVERY 3,000 KM

10'

Action

 Engine oil - level check/ top-up

EVERY 2 YEARS**Action**

 Coolant - change
 Brake fluid - change

AFTER 1000 KM

80'

Action

 Engine oil - replacement
 Hub oil - change
 Engine oil - change
 Idle speed (*) - adjustment
 Throttle lever - adjustment
 Steering - adjustment
 Brake control levers - greasing
 Brake pads - check condition and wear
 Brake fluid level - check
 Safety locks - check
 Electrical system and battery - check
 Tyre pressure and wear - check
 Vehicle and brake test - road test

(*) See instructions in «Idle speed adjustment» section

AT 6000 KM OR 12 MONTHS

80'

Action

 Hub oil level - check
 Spark plug/ electrode gap - check
 Air filter - clean
 Sliding blocks / variable speed rollers - check
 Driving belt - check
 Coolant level - check
 Brake pads - check condition and wear
 Brake fluid level - check
 Electrical system and battery - check
 Tyre pressure and wear - check
 Vehicle and brake test - road test

AT 12,000 KM OR 24 MONTHS 60,000 KM

100'

Action

 Engine oil - replacement
 Hub oil level - check

Action

Spark plug / electrode gap - check / replacement
Air filter - clean
Engine oil - change
Idle speed (*) - adjustment
Sliding block / variable speed rollers - change
Throttle lever - adjustment
Coolant level - check
Steering - adjustment
Brake control levers - greasing
Brake pads - check condition and wear
Brake fluid level - check
Transmission elements - lubrication
Safety locks - check
Suspensions - check
Electrical system and battery - check
Headlight - adjustment
Tyre pressure and wear - check
Vehicle and brake test - road test
Driving belt - check

(*) See regulations in section «Idling speed adjustment»

AT 18,000 KM OR 54,000 KM

155'

Action

Hub oil level - check
Spark plug/ electrode gap - check
Air filter - clean
Valve clearance - check
Sliding blocks / variable speed rollers - check
Coolant level - check
Radiator - external cleaning/ check
Brake pads - check condition and wear
Brake fluid level - check
Electrical system and battery - check
Tyre pressure and wear - check
Vehicle and brake test - road test
Secondary air filter - cleaning
Driving belt - replacement

AT 24000 KM AND AT 48000 KM

150'

Action

Engine oil - replacement
Hub oil - change
Spark plug / electrode gap - check / replacement
Air filter - clean
Engine oil - change
Idle speed (*) - adjustment
Sliding block / variable speed rollers - change
Throttle lever - adjustment
Coolant level - check
Steering - adjustment
Brake control levers - greasing

Action

Brake pads - check condition and wear

Brake fluid level - check

Transmission elements - lubrication

Safety locks - check

Suspensions - check

Electrical system and battery - check

Headlight - adjustment

Tyre pressure and wear - check

Vehicle and brake test - road test

Driving belt - check

() See regulations in section «Idling speed adjustment»***AT 30000 KM, AT 42000 KM AND AT 66000 KM**

80'

Action

Hub oil level - check

Spark plug/ electrode gap - check

Air filter - clean

Variable speed rollers - check or replacement

Driving belt - check

Coolant level - check

Brake pads - check condition and wear

Brake fluid level - check

Electrical system and battery - check

Tyre pressure and wear - check

Vehicle and brake test - road test

AT 36000 KM

250'

Action

Engine oil - replacement

Hub oil level - check

Spark plug / electrode gap - check / replacement

Air filter - clean

Engine oil - change

Idle speed (*) - adjustment

Sliding block / variable speed rollers - change

Throttle lever - adjustment

Driving belt - replacement

Coolant level - check

Radiator - external cleaning/ check

Steering - adjustment

Brake control levers - greasing

Brake pads - check condition and wear

Brake fluid hoses - replacement

Brake fluid level - check

Transmission elements - lubrication

Safety locks - check

Suspensions - check

Electrical system and battery - check

Headlight - adjustment

Tyre pressure and wear - check

Vehicle and brake test - road test

Action

- Secondary air filter - cleaning
- Valve clearance - check

() See regulations in section «Idling speed adjustment»*

AT 72000 KM

270'

Action

- Engine oil - replacement
- Hub oil - change
- Spark plug / electrode gap - check / replacement
- Air filter - clean
- Engine oil - change
- Valve clearance - check
- Idle speed (*) - adjustment
- Sliding block / variable speed rollers - change
- Throttle lever - adjustment
- Driving belt - replacement
- Coolant level - check
- Radiator - external cleaning/ check
- Steering - adjustment
- Brake control levers - greasing
- Brake pads - check condition and wear
- Brake fluid hoses - replacement
- Brake fluid level - check
- Transmission elements - lubrication
- Safety locks - check
- Suspensions - check
- Electrical system and battery - check
- Headlight - adjustment
- Tyre pressure and wear - check
- Secondary air filter - cleaning
- Vehicle and brake test - road test

() See regulations in section «Idling speed adjustment»*

Carburettor

- Disassemble the carburettor in its parts, wash all of them with solvent, dry all body grooves with compressed air to ensure adequate cleaning.
- Check carefully that the parts are in good condition.
- The throttle valve should move freely in the chamber. Replace it in case of excessive clearance due to wear.
- If there are wear marks in the chamber causing inadequate tightness or a free valve slide (even if it is new), replace the carburettor.
- It is advisable to replace the gaskets at every refit

WARNING

PETROL IS HIGHLY EXPLOSIVE ALWAYS REPLACE THE GASKETS TO AVOID PETROL LEAKS

1. Diaphragm cover - 2. Throttle valve spring - 3. Conical needle support - 4. Conical needle spring - 5. Conical needle - 6. Throttle valve diaphragm - 7. Automatic starting device - 8. Idle speed adjusting screw - 9. Accelerating pump rocker - 10. Idle mixture adjusting screw - 11. Float pin - 12. Accelerating pump assembly - 13. Float - 14. Float chamber - 15. Idling jet - 16. Main jet - 17. Diffuser - 18. Float chamber drain screw.

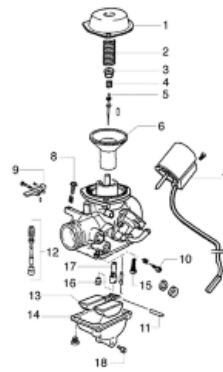

Checking the spark advance

- To check ignition advance, use the stroboscopic light with induction pincers connected to the spark plug power wire.
- Connect the induction pincers being careful to respect the proper polarity (the arrow stamped on the pincers must be pointing at the spark plug).
- Place the light selector in central position (1 spark = 1 crankshaft turn as in 2-T engines).
- Start the engine and check that the light works properly and the rpm indicator can read also the high rpm (e.g. 8000 rpm).
- If flash unsteadiness or revolution reading error is detected (e.g. half values), increase the resistive load on the spark plug power line (10 ÷ 15 KΩ in series to HV wire).

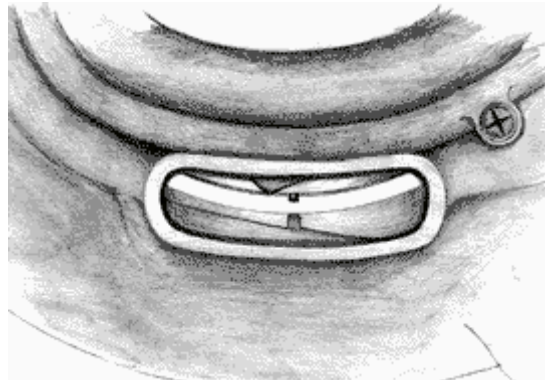

- Remove the spark plug.
- Remove the plastic cover from the slotted hole on the flywheel cover, indicated in the picture.

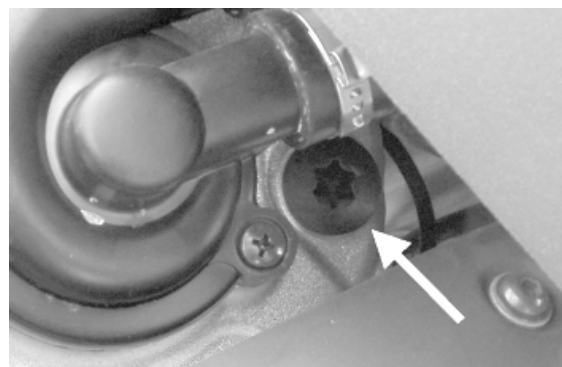

- Remove the transmission compartment air intake cover shown in the photograph.

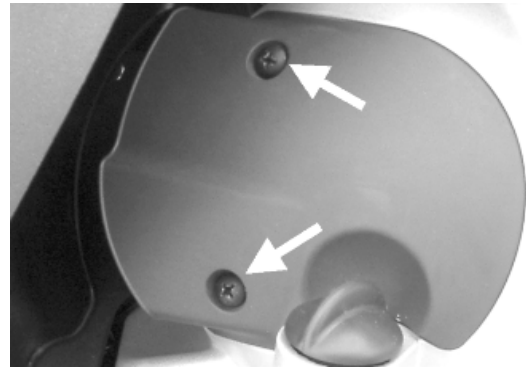

- Using a screwdriver rotate the fan, mounted onto the drive pulley, until the marking on the flywheel is aligned with that stamped on the flywheel cover, as shown in the picture.

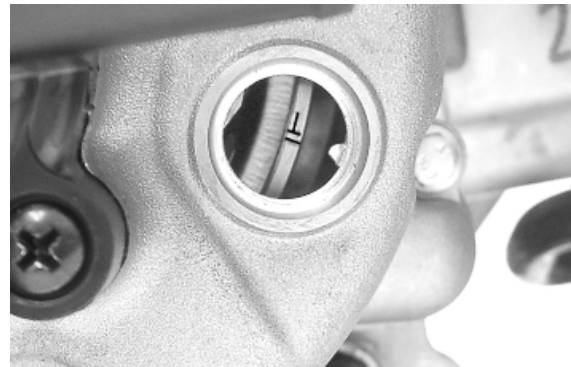

- Mark the alignment between fan and transmission cover on the transmission side, as shown in the picture.
- Refit the spark plug.
- Refit the plastic cover on the flywheel cover.



Characteristic

Spark advance check

from $10^{\circ} \pm 1^{\circ}$ to 2000 rpm

through $28^{\circ} \pm 1^{\circ}$ to 6500 rpm

- Check that the advance degrees match the revolution speed as indicated in the tables.
- In case of abnormal values, check the Pick-Up and the control unit supplies (positive-negative); replace the control unit, if required.
- A new control unit prevents the engine from rotating at over 2,000 rpm.
- The programmed control unit allows the engine revolution within the prescribed limits.

Specific tooling

020330Y Stroboscopic light for timing control

Spark advance variation

SPARK ADVANCE VARIATION

Specification	Desc./Quantity
Operation threshold	First threshold : 9600±50 Second threshold : 9800±50
Reactivation threshold	First threshold : 9500±50 Second threshold : 9700±50
Spark elimination	First threshold : 1 spark on 7 Second threshold : 2 sparks on 3

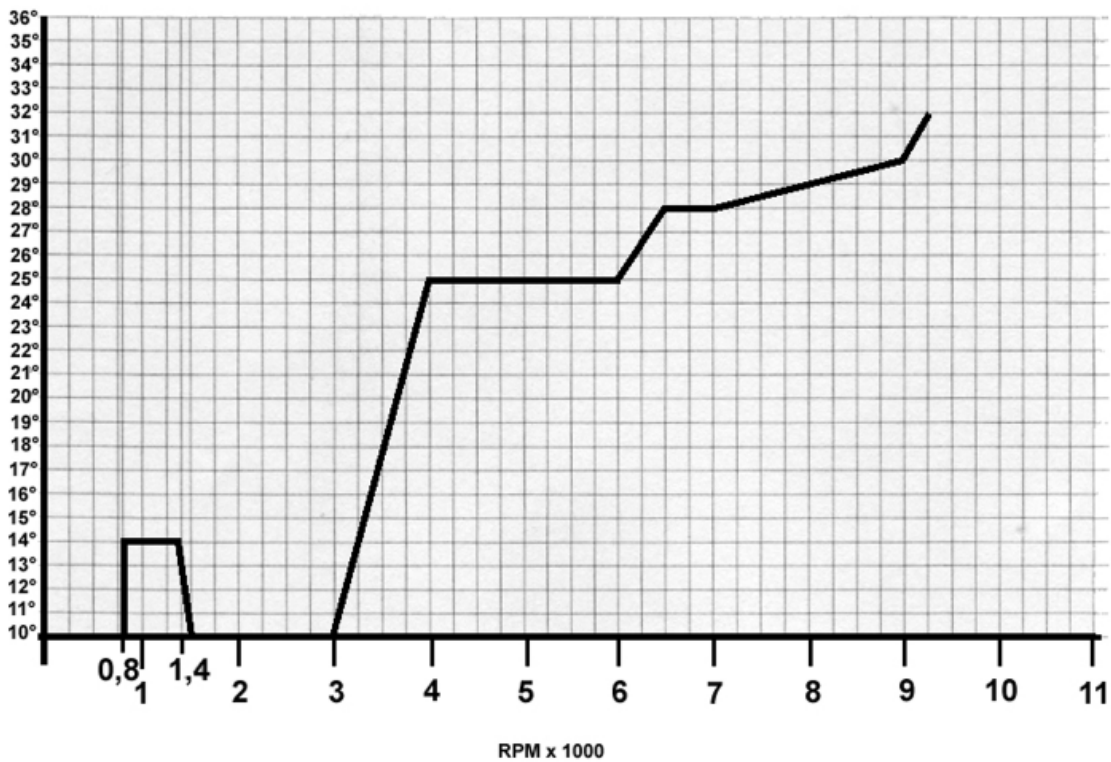

Spark plug

- Put the vehicle on the central stand.
- Open the door on the left side of the vehicle by levering in the recess in the lower part of the door after removing the screw.
- Disconnect the spark plug HV cable cap. - Unscrew the spark plug with the spanner provided.
- Check the spark plug to see if the insulator is cracked, the electrodes are worn out or excessively sooty. Also check the condition of the seal washer and measure the spark gap with a suitable thickness gauge.
- If necessary adjust the spark gap by carefully bending the side electrode. If the spark plug has any of the defects mentioned above, replace it with a plug of the recommended type.
- Insert the plug into the hole with the proper inclination, screw it in fully by hand and then tighten it with the specially designed spanner.
- Push the spark plug cap all the way down onto the spark plug and then proceed to the reassembly.

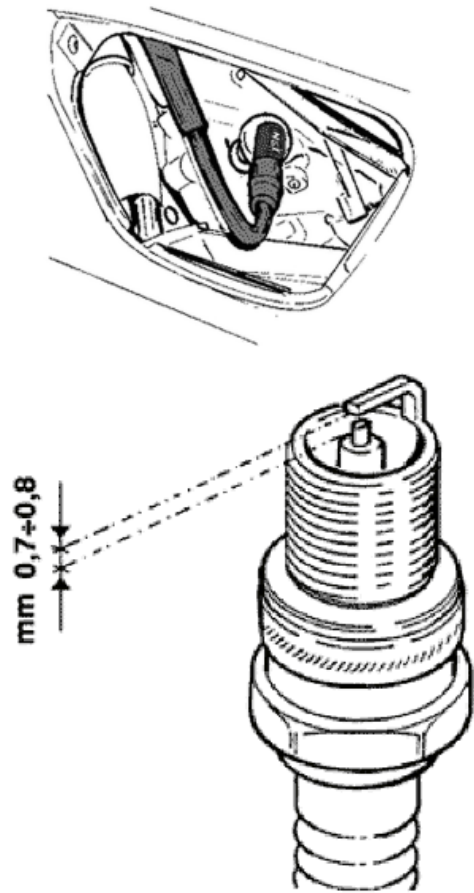

CAUTION

THE SPARK PLUG MUST BE REMOVED WHEN THE MOTOR IS COLD. THE SPARK PLUG MUST BE REPLACED EVERY 12,000 KM. THE USE OF NON CONFORMING IGNITION CONTROL UNITS OR SPARK PLUGS OTHER THAN THOSE PRESCRIBED CAN SERIOUSLY DAMAGE THE ENGINE.

Characteristic

Recommended spark - plug 1

Champion RG 4 HC

Spark plug: electrode distance

0.7 mm ÷ 0.8 mm

Locking torques (N*m)

Spark plug 12 ÷ 14

Hub oil

Check

- Stand the vehicle on its centre stand on flat ground;
- Remove the oil dipstick «A», dry it with a clean cloth and put it back into its hole **tightening it completely**;
- Take out the dipstick checking that the oil level reaches the dipstick bottom notch (see figure); if the level is under the MAX. mark, it needs to be filled with the right amount of hub oil.
- Screw up the oil dipstick again and make sure it is locked properly into place.

The notches on the hub oil level dipstick, except for the notch indicating the MAX level, refer to other manufacturer's models and have no specific function for this model.

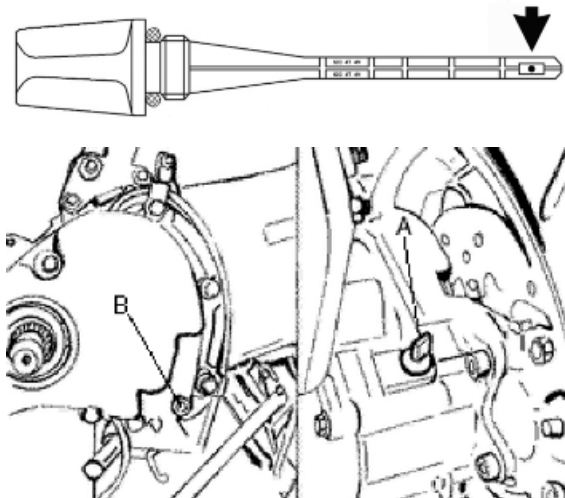

Replacement

- Remove the oil filler cap «A».
- Unscrew the oil drainage plug «B» and drain out all the oil.
- Screw the drainage plug again and fill the hub with oil.

Recommended products

AGIP ROTRA 80W-90 rear oil hub

SAE 80W/90 Oil that exceeds the requirements of API GL3 specifications

Locking torques (N*m)

Hub oil drainage screw 15 ÷ 17 Nm

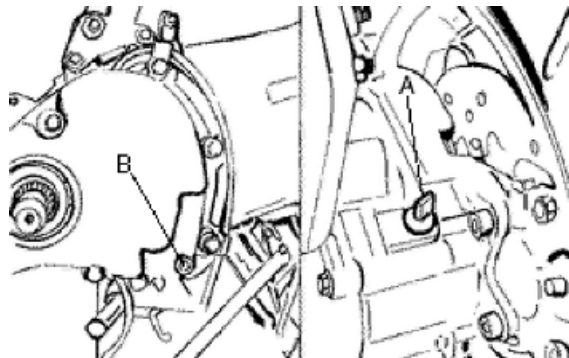

Air filter

- Remove the left side panel.
- Remove the air cleaner cover after unscrewing the 9 fixing screws.
- Take out the filtering element.
- Replace the air filter with a new one.

N.B.

EVERY 6,000 KM CHECK THE AIR FILTER AND IF REQUIRED, CLEAN IT WITH COMPRESSED AIR. THE AIR JET MUST BE DIRECTED FROM THE INSIDE TO THE OUTSIDE OF THE FILTER (I.E. OPPOSITE TO THE SENSE THE AIR

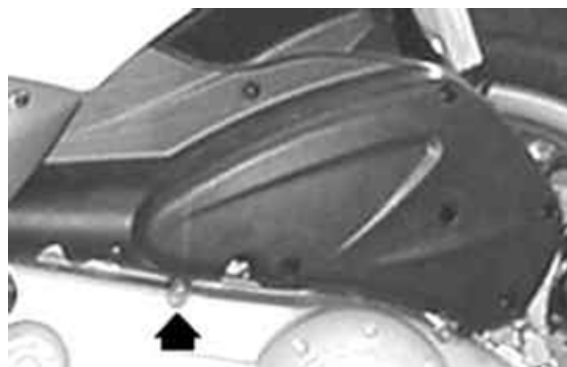

FLOWS AT REGULAR ENGINE RUNNING). EVERY 6,000 KM, UPON SERVICING, REMOVE THE RETAINER AND RUBBER COVER UNDER THE FILTER HOUSING AS SHOWN IN THE FIGURE AND DRAIN ALL POSSIBLE OIL DEPOSITS.

Cleaning (Every 12,000 km):

- Wash with water and car shampoo.
- Dry with short blasts of compressed air and a clean cloth.
- Soak with a 50% mixture of gasoline and oil.
- Drip dry the filtering element and then squeeze it with your hands without wringing.
- Refit the filtering element.

CAUTION

NEVER RUN THE ENGINE WITHOUT THE AIR FILTER, THIS WILL RESULT IN AN EXCESSIVE CYLINDER AND PISTON WEAR AND ALSO IN CARBURETTOR DAMAGE.

CAUTION

WHEN TRAVELLING ON DUSTY ROADS, THE AIR FILTER MUST BE CLEANED MORE OFTEN THAN SHOWN IN THE SCHEDULED MAINTENANCE CHART.

Recommended products

AGIP FILTER OIL Oil for air filter sponge

Mineral oil with specific additives for increased adhesiveness

See also

[Footrest](#)

Engine oil

Replacement

The engine oil should be replaced after the first 1,000 km, and then every 12,000 km. The engine must be drained through the net filter draining cap «B» on flywheel side; in addition, to facilitate the drainage, oil dipstick «A» should be loosen. Once the engine oil has been drained, remove oil cartridge «C».

Since a certain oil quantity remains inside the circuit, the fill-up must be carried out with 600-650cc of fresh oil poured through filler cap «A». Hence start the vehicle, let the engine run for a few minutes, and then shut it back down; after approx.

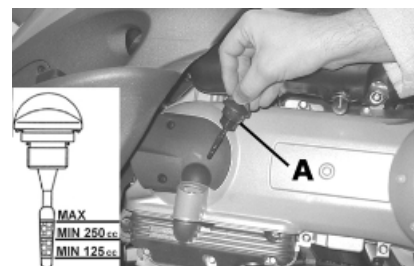

five minutes, check the level and top-up if necessary, without exceeding the **MAX** mark.

N.B.

THE ENGINE MUST BE HOT WHEN THE OIL IS CHANGED.

Recommended products

AGIP CITY HI TEC 4T Engine oil

SAE 5W-40 Synthetic oil that exceed the requirements of API SL, ACEA A3, JASO MA specifications

Locking torques (N*m)

Engine oil drainage plug 24 ÷ 30

See also

[Engine oil filter](#)

Check

In 4T engines, the engine oil is used to lubricate the distribution elements, the bench bearings and the thermal group. **An insufficient quantity of oil can cause serious damage to the engine.** In all 4T engines, the deterioration of the oil's characteristics, or a certain consumption should be considered normal, especially if during the run-in period. Consumption can particularly reflect the conditions of use (i.e. when driving at "full acceleration" all the time, oil consumption increases).

Perform this operation when the engine cold, as described below:

- 1) Put the vehicle on its central stand on a flat surface.
- 2) Unscrew dipstick "A", dry it with a clean cloth and refit by **screwing it completely**.
- 3) Remove the dipstick again and check that the oil level is between the MAX and MIN marks on the dipstick; top up if necessary.

The MAX level mark indicates an amount of about 1100 cc of engine oil. The level will be lower if checked after using the vehicle (i.e. when the engine is hot). To obtain a correct indication of the oil level, wait for at least 10 minutes after switching off the engine.

Characteristic

Engine oil

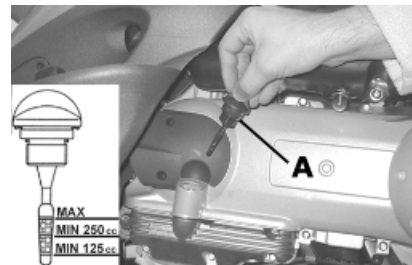

~ 1200 cc

The oil should be topped up after having checked the level and in any case by adding oil **without ever exceeding the MAX. level.**

Restoring the level between the **MIN** and **MAX** reference marks requires ~ 400 cm³ of oil.

Engine oil filter

The cartridge filter must be replaced every time the oil is changed. Use new oil of the recommended type for topping up and changing purposes.

Make sure the pre-filter and drainage plug O-rings are in good conditions. Lubricate them and refit the mesh filter and oil drainage plug, screwing them up to the specified torque. Refit the new cartridge filter being careful to lubricate the O-ring before the fitting. Change the engine oil.

Recommended products

AGIP CITY HI TEC 4T Engine oil

SAE 5W-40 Synthetic oil that exceed the requirements of API SL, ACEA A3, JASO MA specifications

Oil pressure warning light

The vehicle is equipped with a warning light on the instrument panel that lights up when the key is turned to the "ON" position. However, this light should switch off once the engine has been started.

If the light turns on during braking, at idling speed or while turning a corner, it is necessary to check the oil level and the lubrication system.

Checking the ignition timing

-Remove the 4 fixing screws and move away from the engine the flywheel cover fitted with a water pump and cooling manifolds.

-Rotate the flywheel until the reference matches the crankcase operation end as shown in the figure (TDC). Make sure that the 4V reference point on the camshaft control pulley is aligned with the reference point on the head as shown in the second figure. If the reference mark is opposite the indicator on the head, make the crankshaft turn once more.

-The TDC reference mark is repeated also between the flywheel cooling fan and the flywheel cover.

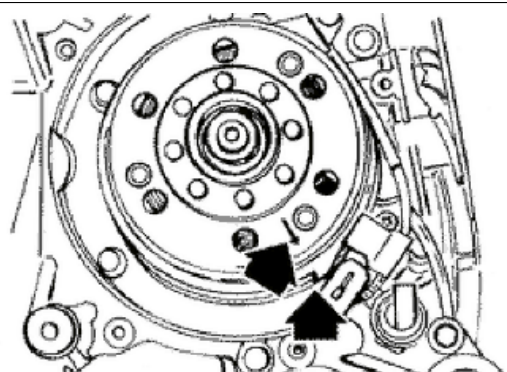

To use this reference mark, remove the spark plug and turn the engine in the opposite direction to the normal direction using a calliper spanner applied to the camshaft command pulley casing.

N.B.

TIME THE TIMING SYSTEM UNIT IF IT IS NOT IN PHASE.

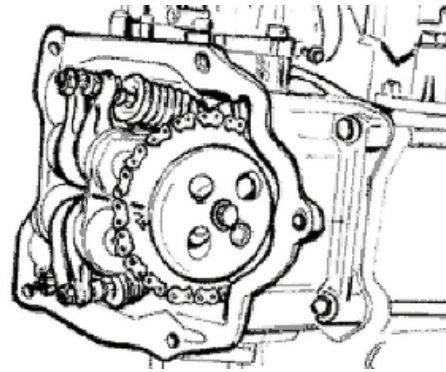

Checking the valve clearance

-To check valve clearance, centre the reference marks of the timing system

- Use a thickness gauge to check that the clearance between the valve and the register corresponds with the indicated values. When the valve clearance values, intake and drainage respectively, are different from the ones indicated below, adjust them by loosening the lock nut and operate on the register with a screwdriver as shown in the figure.

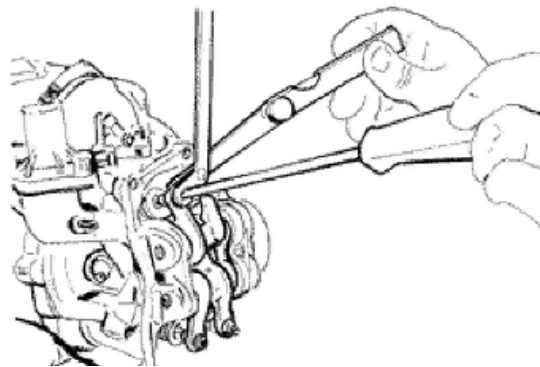

Intake: 0.10 mm (when cold)

Discharge: 0.15 mm (when cold)

Cooling system

Level check

- To check the level, it is necessary to look inside the expansion tank: a mark on the side of the filler indicates MIN and MAX levels.

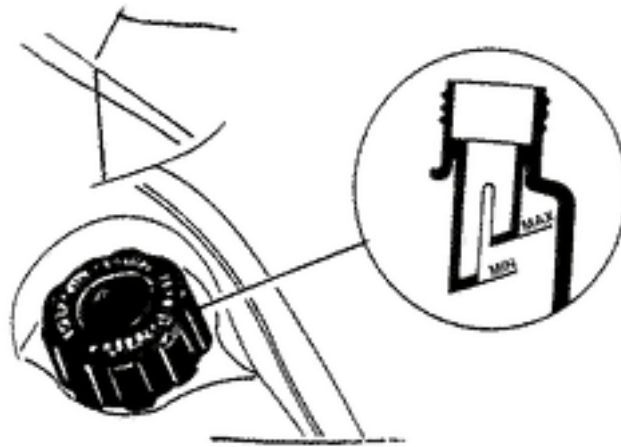

Top-up

The fluid level inspection should be carried out every 6,000 km when the motor is cold, following the methods indicated below:

Place the scooter on its centre stand and on flat ground.

- Undo the screw shown in the figure and remove the expansion tank cap on RHS.
- Remove the cap of the expansion tank and top up the fluid level if it is near or below the MIN mark inside the tank. The coolant level must always be between MIN and MAX. level.
- The coolant consists of an ethylene glycol and corrosion inhibitor based 50% de-ionised water- anti-freeze solution mix.

CAUTION

DO NOT EXCEED THE MAX. LEVEL WHEN FILLING SO AS TO AVOID THE COOLANT ESCAPING FROM THE EXPANSION TANK WHEN THE vehicle IS IN USE.



Braking system

Level check

The brake fluid tanks for the front and rear brakes are located on the pumps under the handlebar cover. Proceed as follows:

- Bring the scooter onto the centre stand and with the handlebar centred;
- check the fluid level at the sight glass as shown in the figure.

A certain lowering of the level is caused by wear on the pads.



Top-up

- Remove the cap on the handlebar cover as shown in the photograph.

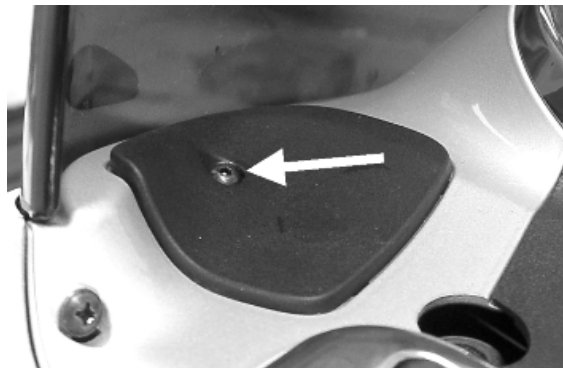

- Remove the tank cap by loosening the two screws, remove the gasket and top up using only the liquid specified without exceeding the maximum level.

CAUTION

ONLY USE DOT 4-CLASSIFIED BRAKE FLUID.

CAUTION

MAKE SURE THE BRAKE FLUID DOES NOT GET INTO YOUR EYES OR ON YOUR SKIN OR CLOTHES. IF THIS HAPPENS ACCIDENTALLY, WASH WITH WATER.

CAUTION

BRAKE CIRCUIT FLUID IS VERY CORROSIVE; MAKE SURE THAT IT DOES NOT COME INTO CONTACT WITH THE PAINTWORK.

CAUTION

THE BRAKE FLUID IS HYGROSCOPIC, IN OTHER WORDS, IT ABSORBS MOISTURE FROM THE SURROUNDING AIR. IF THE CONTENT OF MOISTURE IN THE BRAKING FLUID EXCEEDS A CERTAIN VALUE, BRAKING WILL BE INEFFICIENT.



**NEVER USE BRAKE LIQUID IN OPEN OR PARTIALLY USED CONTAINERS.
UNDER NORMAL CLIMATIC CONDITIONS,
THE FLUID MUST BE CHANGED EVERY 20,000
KM OR ANYWAY EVERY TWO YEARS.**

Recommended products

AGIP BRAKE 4 Brake fluid

FMVSS DOT 4 Synthetic fluid

Headlight adjustment

- Place the unloaded vehicle on a level surface, 10 metres from a half-lit white screen, with the tyres inflated to the prescribed pressure. Ensure that the axis of the vehicle is perpendicular to the screen.
- Draw a horizontal line on the screen 69 ÷ 72 cm above the ground.
- Switch on the headlight, turn on the low beam and check that the horizontal line that divides the dark area from the lighted area is not above the line previously drawn on the screen. To shift the headlight, turn the adjusting screw in the glove compartment (see figure).

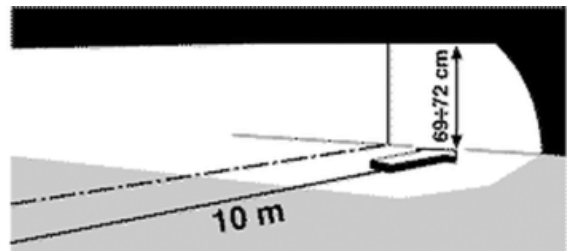

CO check

- Remove RHS footrest.
- Remove the gas cap on the exhaust pipe.
- Using the original washer, install the exhaust gas collection kit as shown in the picture.

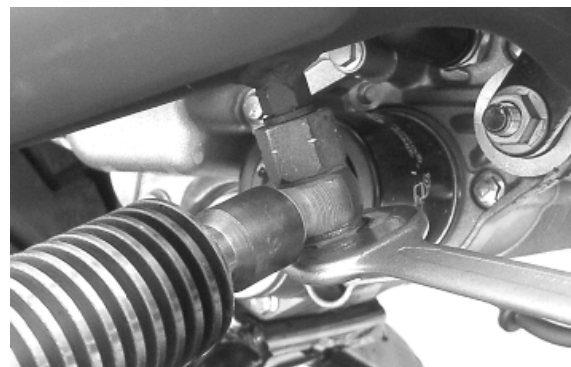

- Suitably orientate all the components.
- Shut the gas outlet terminal of the tool.
- Start the engine and let it warm up until the electric fan activates.
- Stop the engine.



- Disconnect the SAS check valve vacuum hose shown in the figure.
- Seal the connection using a conical cap.

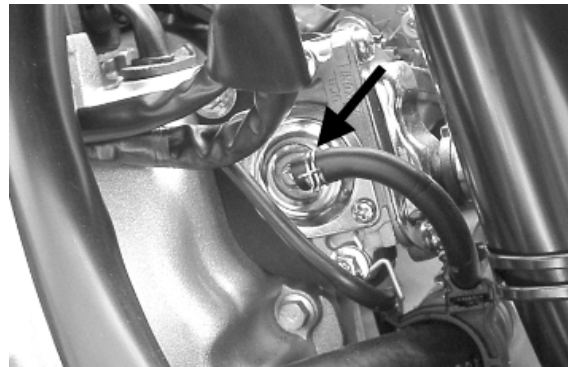

- Connect the Mitivac vacuum pump to the SAS control valve.
- Start the vacuum pump up to a pressure of -0.6 ÷ -0.8 bar so to close the valve and cut off the SAS system.
- Remove the exhaust gas collection kit cap and connect the analyzer adequately pre-heated.
- Check the analyser output and the engine rpm.
- Adjust the CO concentration.

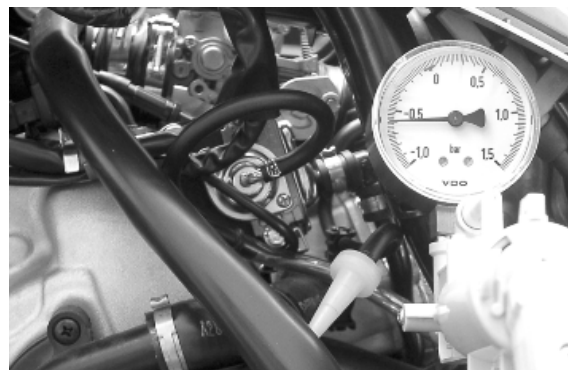

N.B.

CHECK THAT THE RESULT IS OBTAINED WITH THE VALVE GAS IN CLOSED POSITION.

N.B.

ALSO CHECK THE CARBURETION ADJUSTMENT IS OBTAINED WITH THE FLOW SCREW OPEN BETWEEN 2 AND 4 TURNS.

N.B.

OTHERWISE, CHECK THE FUEL LEVEL ADJUSTMENT IN THE TANK AND THE FUEL CIRCUIT.

N.B.

IN CASE OF UNSTABLE CO, CHECK THAT THE CARBURETTOR IS CLEAN AND THAT

THE FUEL SUPPLY SYSTEM AND THE DEPRESSION SEALS WORK ADEQUATELY

N.B.

IN CASE OF 1000 PPM UNBURNED HYDROCARBONS (HC) >, CHECK THE IGNITION SYSTEM, THE TIMING SYSTEM, THE VALVE CLEARANCE AND THE EXHAUST VALVE TIGHTNESS.

Specific tooling

020329Y MityVac vacuum-operated pump

020332Y Digital rev counter

494929Y Exhaust fumes analyser

020625Y Kit for sampling gas from the exhaust manifold

Characteristic

CO Check

3.8±0.7 to 1650±50 RPM

SAS filters inspection and cleaning

- Remove LHS footrest.
- Remove the air-box/crankcase fixing screws.
- Remove the three fixings shown in the figure.

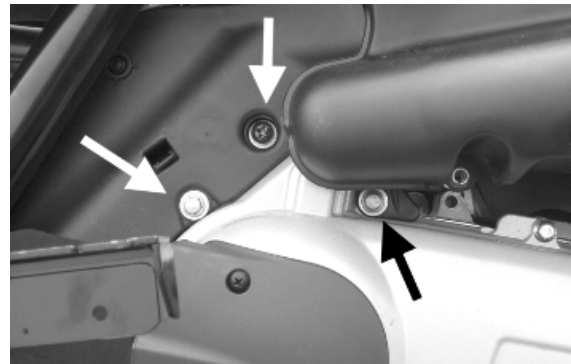

- Detach the oil vapours recovery line and the choke cable harness from the clamp shown in the picture.
- Remove the plastic fairing.

- Remove the two screws shown in the picture.

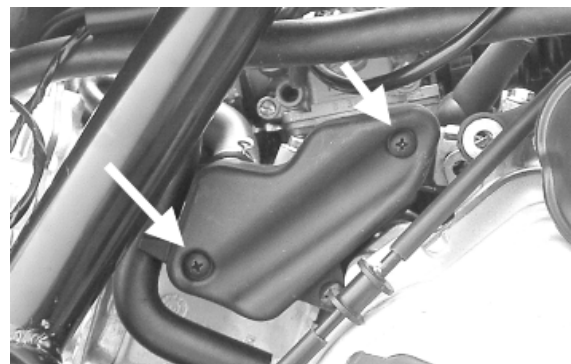

- Remove the filter indicated in the photograph
- Check that the gasket is in good conditions
- Check the SAS filter housing for dents or deformations
- Clean the SAS filter carefully. Replace the filter if it is damaged or deformed.



To refit, carry out the removal operations but in reverse order.

CAUTION

WHEN TRAVELLING ON DUSTY ROADS, THE AIR FILTER MUST BE CLEANED MORE OFTEN THAN SHOWN IN THE SCHEDULED MAINTENANCE CHART.

CAUTION

NEVER RUN THE ENGINE WITHOUT THE SECONDARY AIR FILTER

See also

[Footrest](#)

Anti-evaporation system

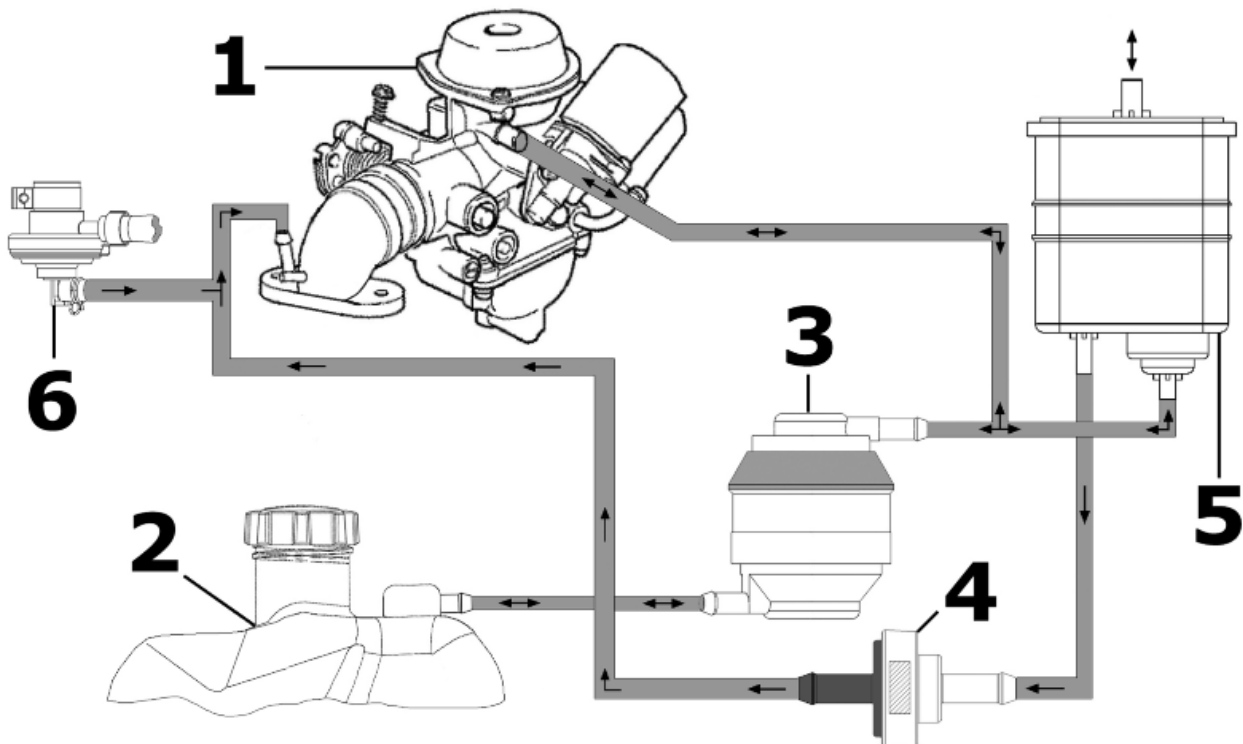

ANTI-EVAPORATION SYSTEM

Specification	Desc./Quantity
1. Carburettor	
2. Fuel tank	

Specification	Desc./Quantity
3. Roll-over valve	
4. Safety valve	
5. Canister	
6. Vacuum fuel tap	

Removing system components

- Canister Removal

Gain access to the canister by removing the cover located inside the helmet compartment. Release the retaining belt and metallic clamps, then remove the hoses.

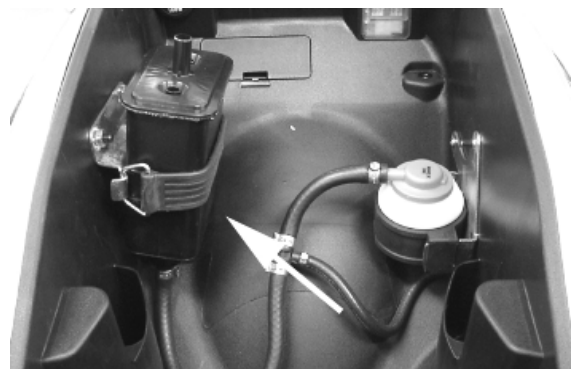
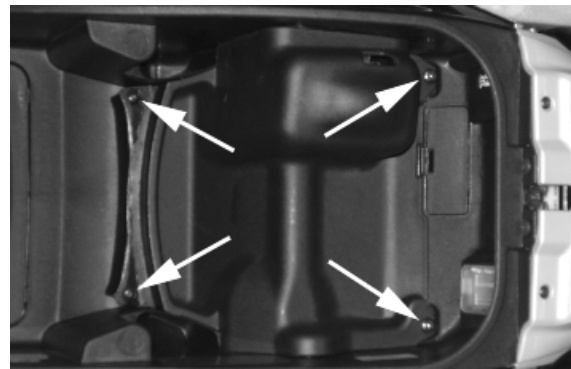

- Roll-over valve removal

Reach for the valve by removing the cover located inside the helmet compartment. Detach the retaining latch, and remove the metal clamps and hoses.

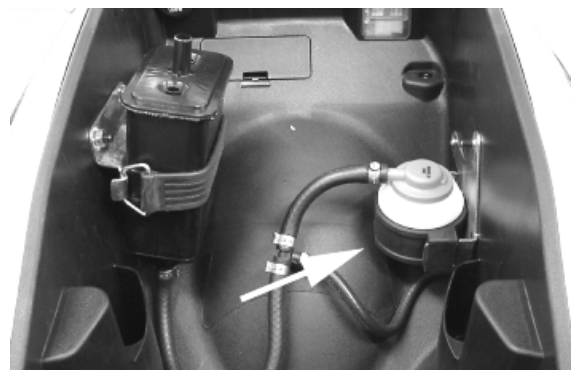

- Roll-over and/or Safety Valve Removal

Remove the cover, release the metallic clamps, and then remove the hoses. The two valves are not supported.

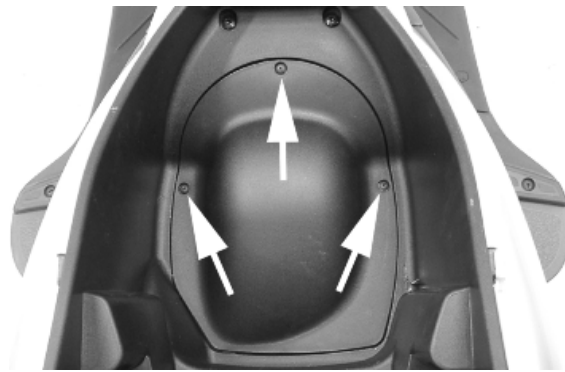

Refitting system components

- Replace the components inserting the piping properly and fastening them with new metal strips.
- Be careful to the direction of installation of the components. The safety valve and the Roll-over valve, if fitted in the reverse direction, affect the operation of the entire anti-evaporation system.



Canister inspection

The Canister is fundamental for treating the hydrocarbons contained inside the volume of gas departing the fuel tank when the internal pressure rises (due to the heat induced by the radiator, engine or ambient temperature).

The volume of air is limited by the operation of ventilation valve (Roll-over).

Even though the quantity of hydrocarbons coming from the tank is fairly small, active carbon should be regenerated by a reversed flow of the ambient air sucked in by the engine, to prevent the saturation of the canister.

This carbon pollution and regeneration phenomena occur during each cycle of utilization of the vehicle.

To check the Canister, it is necessary to proceed with its removal, whilst keeping the two hoses attached.

- Shake the Canister and ensure it emits no noise.
- Using a compressed air gun, blow the 3 ducts and ensure this does not result in a pressure build-up inside the Canister.
- Ensure the airflow is undisturbed and no carbon residues exit the hose.



Replace the Canister if noisy, clogged up, or leaking carbon residues.

Safety valve check

The Canister is cleaned by an air flow controlled by the vacuum inlet located on the intake manifold. To guarantee the correct operation of the engine, the mass air flow must not be excessively large; this is obtained by using a narrow section (0.9mm) for the inlet on the intake manifold.

The Canister tubing connections comprise the installation of a safety valve.

This is a unidirectional valve that ensures the air flow towards the manifold when the control vacuum is over 200mbar.

The engine vacuum at idle causes a weak air flow that can be easily compensated for with the idle adjustment parameters.

When the vehicle is stationary, the safety valve will be shut due to the lack of control vacuum; for this reason, any expansion of the fuel tank will not pollute the intake manifold thus preventing engine floods.

The valve should preferably be removed from the vehicle upon inspection; alternatively, it will be sufficient to access the tubing on the manifold side.

- Connect the MITYVAC pump on the engine side duct.
- Set the pump control onto "vacuum", then slowly apply vacuum to check the valve opening threshold.



If different pressures are found, replace the valve.

N.B. If the opening vacuum is too high, it causes a lack of active carbon regeneration; on the other hand, if it is too low, it increases the air flow rate to the engine, thus causing a poor fuel-oxygen mixture at idle.

Characteristic**Standard opening vacuum**

200 ÷ 260 mbar

Roll-over valve check

The valve should allow the following results:

- Tank aeration when running (ambient air enters into the tank based on the volume of fuel used).
- Tank pressurization (the tank internal temperature may rise when running or while stopped. The valve should pressurize the tank so to limit the amount of fuel vapors departing towards the Canister).

Prevent the liquid fuel pollution of the Canister (if the vehicle falls, the valve should interrupt the connection to the Canister).

The valve must be removed from the vehicle upon inspection.

A MITYVAC pump and a length of pipe are needed for the inspection; proceed as follows:

- Attach the MITYVAC pump to the lower joint to the safety valve (white).
- Set the pump control onto "vacuum" and, whilst keeping the valve aligned with its **vertical axis**, check that air may be sucked in without observing any movements on the manometer needle gauge.
- Set the pump onto "pressure" and, whilst keeping the valve aligned with its **vertical axis**, check that the valve can be pressurized to values slightly below 0.1bar (~60mbar).

N.B. The calibration pressure can be easily recognized as, when reached, the valve will start to discharge air thus emitting a weak noise.

- Align the valve with its **horizontal axis** and check that it can be pressurized to values much higher than the calibration pressure (e.g. 0.5bar without it necessarily being maintained).

Replace the valve if anomalies are found.

N.B. Any valve failure may cause the fuel tank to deform or increase of the Canister operating requirements.

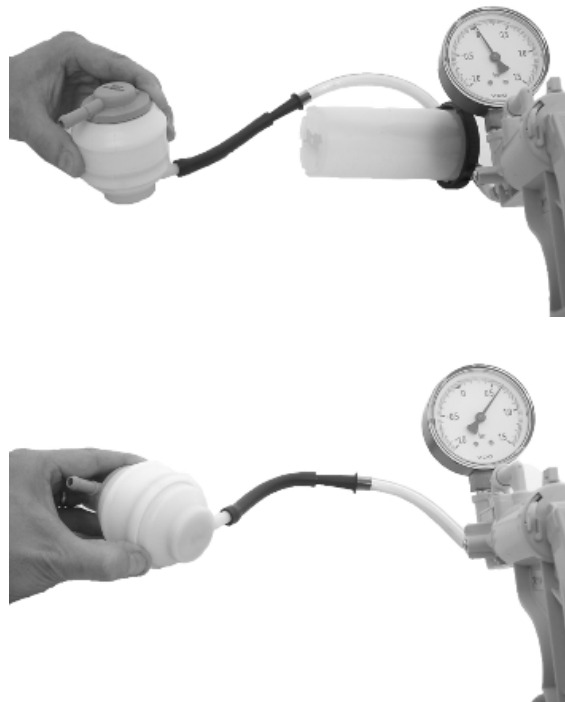

INDEX OF TOPICS

TROUBLESHOOTING

TROUBL

Engine

Poor performance

POOR PERFORMANCE

Possible Cause	Operation
The carburettor is dirty; fuel pump or vacuum valve damaged	Remove, wash with solvent and dry with compressed air or replace
Excess of encrustations in the combustion chamber	Descale the cylinder, the piston, the head and the valves
Incorrect timing or worn timing system elements	Time the system again or replace the worn parts
Muffler obstructed	Replace
Air filter blocked or dirty.	Dismantle the sponge, wash with water and shampoo, then soak it in a mixture of 50% petrol and 50% of specific oil (Selenia Air Filter Oil), then hand dry without squeezing, allow to drip dry and then reassemble.
Automatic starter failure	Check: mechanical movement, electric connection and fuel supply, replace if required.
Oil level exceeds maximum	Check for causes and fill to reach the correct level
Lack of compression: parts, cylinder and valves worn	Replace the worn parts
Transmission belt worn	Replace
Inefficient automatic transmission	Check the rollers and the pulley movement, replace the damaged parts and lubricate the driven pulley moveable guide with Montblanc Molybdenum Grease
Clutch slipping	Check the clutch system and/or the bell and replace if necessary
Overheated valves	Remove the head and the valves, grind or replace the valves
Wrong valve adjustment	Adjust the valve clearance properly
Valve seat distorted	Replace the head assembly
Air filter dirty	Dismantle the sponge, wash with water and shampoo, then soak it in a mixture of 50% petrol and 50% of specific oil (Selenia Air Filter Oil), then hand dry without squeezing, allow to drip dry and then reassemble.
Defective floating valve	Check the proper sliding of the float and the functioning of the valve

Rear wheel spins at idle

REAR WHEEL ROTATES WITH ENGINE AT IDLE

Possible Cause	Operation
Idling rpms too high	Adjust the engine idle speed and the CO%, if necessary.
Clutch fault	Check the springs / clutch masses

Starting difficulties

DIFFICULT STARTING

Possible Cause	Operation
Altered fuel characteristics	Drain off the fuel no longer up to standard; then, refill
Rpm too low at start-up or engine and start-up system damaged	Check the starter motor, the system and the torque limiter
Incorrect valve sealing or valve adjustment	Inspect the head and/or restore the correct clearance
Engine flooded	Try starting-up with the throttle fully open. If the engine fails to start, remove the spark plug, dry it and before refitting, make the motor turn so as to expel the fuel excess taking care to connect the cap to the spark plug, and this in turn to the ground. If the fuel tank is empty, refuel and start up.
Automatic starter failure	Check: mechanical movement, electric connection and fuel supply, replace if required.
Air filter blocked or dirty.	Dismantle the sponge, wash with water and shampoo, then soak it in a mixture of 50% petrol and 50% of specific oil (Selenia Air Filter Oil), then hand dry without squeezing, allow to drip dry and then reassemble.
Faulty spark plug or incorrect ignition advance	Replace the spark plug or check the ignition circuit components
The carburettor is dirty; fuel pump or vacuum valve damaged	Remove, wash with solvent and dry with compressed air or replace
Flat battery	Check the charge of the battery, if there are any sulphur marks, replace and use the new battery following the instructions shown in the chapter
Intake coupling cracked or clamps incorrectly tightened	Replace the intake coupling and check the clamps are tightened
Defective floating valve	Check the proper sliding of the float and the functioning of the valve
Carburettor nozzles clogged	Dismantle, wash with solvent and dry with compressed air

Excessive oil consumption/Exhaust smoke

EXCESSIVE OIL CONSUMPTION/SMOKEY EXHAUST

Possible Cause	Operation
Worn valve guides	Check and replace the head unit if required
Worn valve oil guard	Replace the valve oil guard
Oil leaks from the couplings or from the gaskets	Check and replace the gaskets or restore the coupling seal
Worn or broken piston rings or piston rings that have not been fitted properly	Replace the piston cylinder unit or just the piston rings

Insufficient lubrication pressure

POOR LUBRICATION PRESSURE

Possible Cause	Operation
By-Pass remains open	Check the By-Pass and replace if required. Carefully clean the By-Pass area.
Oil pump with excessive clearance	Perform the dimensional checks on the oil pump components
Oil filter too dirty	Replace the cartridge filter
Oil level too low	Restore the level using the recommended oil type (Selenia HI Scooter 4 Tech)

Engine tends to cut-off at full throttle

ENGINE STOP FULL THROTTLE

Possible Cause	Operation
Faulty fuel supply	Check or replace the pump and the vacuum valve, check the vacuum intake and the pipe sealing
Incorrect float level	Restore the level in the tank by bending on the float the thrusting reed of the petrol inlet rod so as to have the float parallel to the tank level with the carburettor inverted.
Water in the carburettor	Empty the tank through the appropriate bleed nipple.
Maximum nozzle dirty - lean mixture	Wash the nozzle with solvent and dry with compressed air

Engine tends to cut-off at idle

ENGINE STOP IDLING

Possible Cause	Operation
Incorrect timing	Time the system and check the timing system components
Cut off device failure	Check that the following parts work properly: valve; diaphragm; spring; and that the air calibration elements are clean; check if the sponge filter is clean too
Incorrect idle adjustment	Adjust using the rpm indicator
Pressure too low at the end of compression	Check the thermal group seals and replace worn components
Faulty spark plug or incorrect ignition advance	Replace the spark plug or check the ignition circuit components
The starter remains on	Check: electric wiring, circuit not interrupted, mechanical movement and power supply; replace if necessary
Minimum nozzle dirty	Wash the nozzle with solvent and dry with compressed air

Excessive exhaust noise

EXCESSIVE EXHAUST NOISE

Possible Cause	Operation
Secondary air device cut-off valve not working	Replace the secondary air device
Depression intake pipe of the secondary air device disconnected or dented	Replace the pipe
Reed valve of the secondary air device does not close correctly and wears out the rubber coupling between the device and the head pipe	Replace the device and the coupling

High fuel consumption

HIGH FUEL CONSUMPTION

Possible Cause	Operation
Float level	Restore the level in the tank by bending on the float the thrusting reed of the petrol inlet rod so as to have the float parallel to the tank level with the carburettor inverted.
Loose nozzles	Check the maximum and minimum nozzles are adequately fixed in their fittings
Fuel pump failure	Check that there is no fuel in the low-pressure duct
Starter inefficient	Check: electric wiring, circuit continuity, mechanical sliding and power supply
Air filter blocked or dirty.	Dismantle the sponge, wash with water and shampoo, then soak it in a mixture of 50% petrol and 50% of specific oil (Selenia Air Filter Oil), then hand dry without squeezing, allow to drip dry and then reassemble.

SAS malfunctions

ANOMALIES IN THE SECONDARY AIR DEVICE

Possible Cause	Operation
Secondary air device cut-off valve not working	Replace the secondary air device
Depression intake pipe of the secondary air device disconnected or dented	Replace the pipe
Reed valve of the secondary air device does not close correctly and wears out the rubber coupling between the device and the head pipe	Replace the device and the coupling

Transmission and brakes

Clutch grabbing or performing inadequately

IRREGULAR CLUTCH PERFORMANCE OR SLIPPAGE

Possible Cause	Operation
Faulty clutch	Check that there is no grease on the masses. Check that the clutch mass contact surface with the casing is mainly in the centre with equivalent characteristics on the three masses. Check that the clutch casing is not scored or worn in an anomalous way

Insufficient braking

INSUFFICIENT BRAKING

Possible Cause	Operation
Inefficient braking system	Check the pad wear (1.5 min). Check that the brake discs are not worn, scored or warped. Check the correct level of fluid in the pumps and replace brake fluid if necessary. Check there is no air in the circuits; if necessary, bleed the air. Check that the front brake calliper moves in axis with the disc.
Fluid leakage in hydraulic braking system	Failing elastic fittings, plunger or brake pump seals, replace

Brakes overheating

BRAKES OVERHEATING

Possible Cause	Operation
Rubber gaskets swollen or stuck	Replace gaskets.
Compensation holes on the pump clogged	Clean carefully and blast with compressed air
Brake disc slack or distorted	Check the brake disc screws are locked; use a dial gauge and a wheel mounted on the vehicle to measure the axial shift of the disc.
Defective piston sliding	Check calliper and replace any damaged part.

Braking vibrations or noise

VIBRATIONS OR NOISE WHEN BRAKING

Possible Cause	Operation
Brake disc slack or distorted	Check the brake disc screws are locked; use a dial gauge and a wheel mounted on the vehicle to measure the axial shift of the disc.

Electrical system

Battery

BATTERY

Possible Cause	Operation
Battery	This is the device in the system that requires the most frequent attention and the most thorough maintenance. If the vehicle is not used for some time (1 month or more) the battery needs to be re-charged periodically. The battery runs down completely in the course of 3 months. If the battery is fitted on a motorcycle, be careful not to invert the connections, keeping in mind that the black ground wire is connected to the negative terminal while the red wire is connected to the terminal marked+.

Turn signal lights malfunction

TURN INDICATOR NOT WORKING

Possible Cause	Operation
Electronic ignition device failure	With the key switch set to "ON" jump the contacts 1 (Blue - Black) and 5 (Red/Blue) on the control unit connector. If by operating the turn indicator control the lights are not steadily on, replace the control unit; otherwise, check the cable harness and the switch.

Steering and suspensions

Heavy steering

STEERING HARDENING

Possible Cause	Operation
Steering hardening	Check the tightening of the top and bottom ring nuts. If irregularities continue in turning the steering even after making the above adjustments, check the seats in which the ball bearings rotate: if they are recessed or if the balls are squashed, replace them.

Excessive steering play

EXCESSIVE STEERING BACKLASH

Possible Cause	Operation
Torque not conforming	Check the tightening of the top and bottom ring nuts. If irregularities continue in turning the steering even after making the above adjustments, check the seats in which the ball bearings rotate:

Possible Cause

Operation

if they are recessed or if the balls are squashed, replace them.

Noisy suspension

NOISY SUSPENSION

Possible Cause

Operation

Malfunctions in the suspension system

If the front suspension is noisy, check: the efficiency of the front shock absorbers; the condition of the ball bearings and relevant lock-nuts, the limit switch rubber buffers and the movement bushings. In conclusion, check the tightening torque of the wheel hub, the brake calliper, the shock absorber disk in the attachment to the hub and the steering tube.

Suspension oil leakage

OIL LEAKAGE FROM SUSPENSION

Possible Cause

Operation

Seal fault or breakage

Replace the shock absorber Check the condition of wear of the steering covers and the adjustments.

INDEX OF TOPICS

ELECTRICAL SYSTEM

ELE SYS

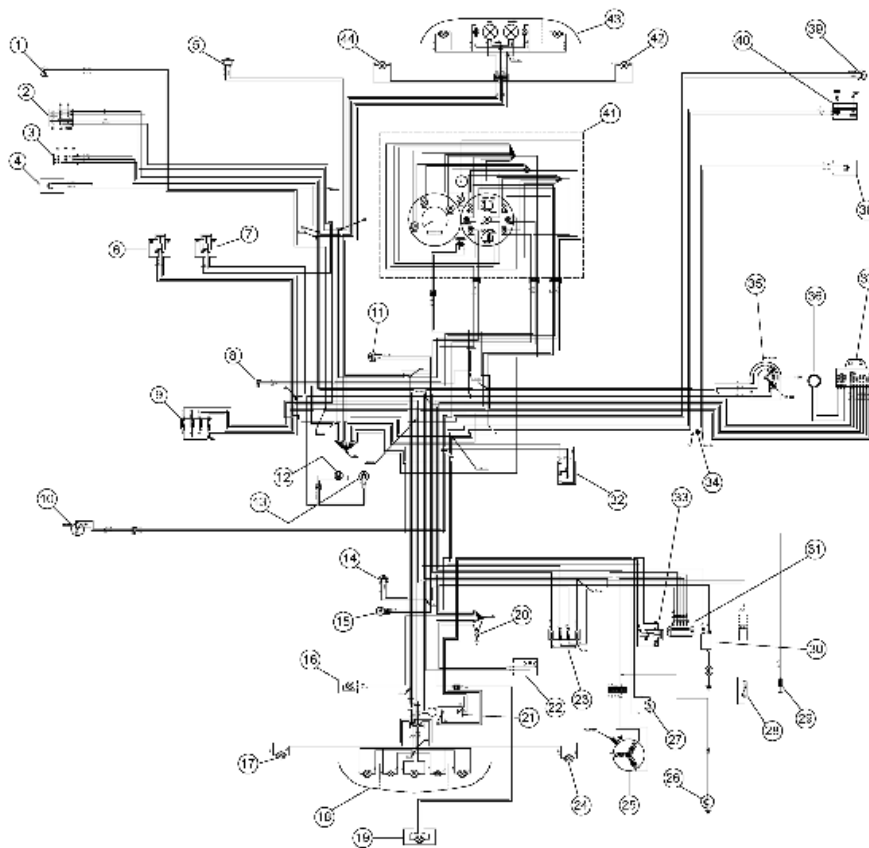

LEGENDA

	Specification	Desc./Quantity
1	Rear stop light switch	
2	Light switch with flash	
3	Turn signal switch	
4	Horn button	
5	Horn	
6	Engine stop remote control switch	
7	Light remote control switch	
8	Intercom pre-wiring	
9	Front fuse holder box	
10	Side stand switch	
11	Saddle opening button	
12	Electric fan	
13	Thermal switch	
14	light button	
15	Saddle opener actuator	
16	Helmet compartment glass bowl	
17	Rear LHS turn signal light	
18	rear headlight	
19	License plate lamp	
20	Frame earth	
21	Battery	
22	Socket 12V	
23	Rear fuse box	
24	Rear RHS turn signal light	
25	Flywheel magneto	

	Specification	Desc./Quantity
26	Engine oil pressure sensor	
27	Starter motor	
28	Automatic starter	
29	Thermistor	
30	H.V. coil	
31	Voltage regulator	
32	fuel sender	
33	Starter relay	
34	Diode	
35	Ignition key-switch	
36	Immobilizer aerial	
37	Electronic ignition device	
38	Start up button	
39	Front brake stop light switch	
40	Engine stop switch	
41	Instrument panel	
42	Front RHS turn signal light	
43	front headlight	
44	Front LHS turn signal light	

Key

Ar: Orange **Az:** Sky blue **Bi:** White **Bl:** Blue **Gi:** Yellow **Gr:**Grey

Ma:Brown **Ne:** Black **Ro:** Pink **Rs:** Red **Ve:** Green **Vi:** Purple

Electrical system installation

Front side

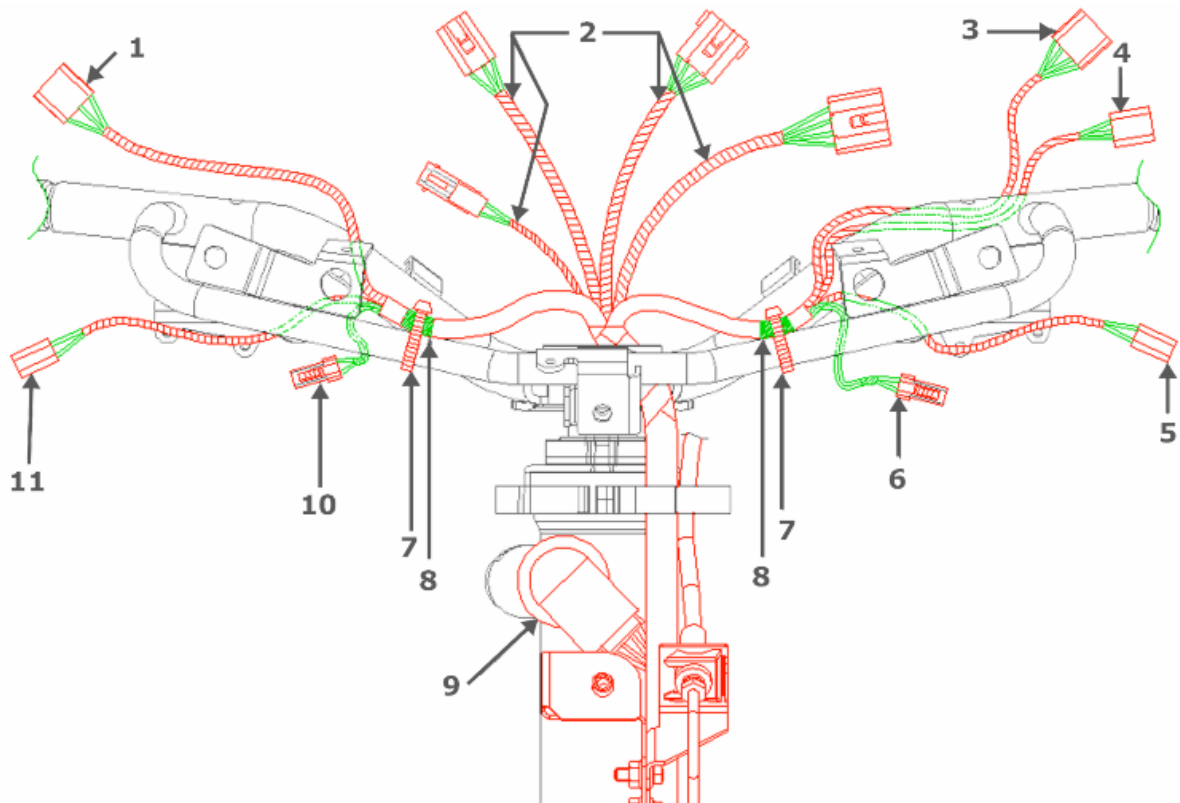

INSTALLING THE ELECTRICAL CIRCUIT

	Specification	Desc./Quantity
1	Installing the electrical circuit	To engine cut-off switch
2	Installing the electrical circuit	To instrument panel
3	Installing the electrical circuit	To headlight switch
4	Installing the electrical circuit	To turn signal switch
5	Installing the electrical circuit	To horn button
6	Installing the electrical circuit	To LHS stop light switch
7	Installing the electrical circuit	Clamp
8	Installing the electrical circuit	Red binding
9	Installing the electrical circuit	Key-switch cap
10	Installing the electrical circuit	To RHS stop light switch
11	Installing the electrical circuit	To starter button

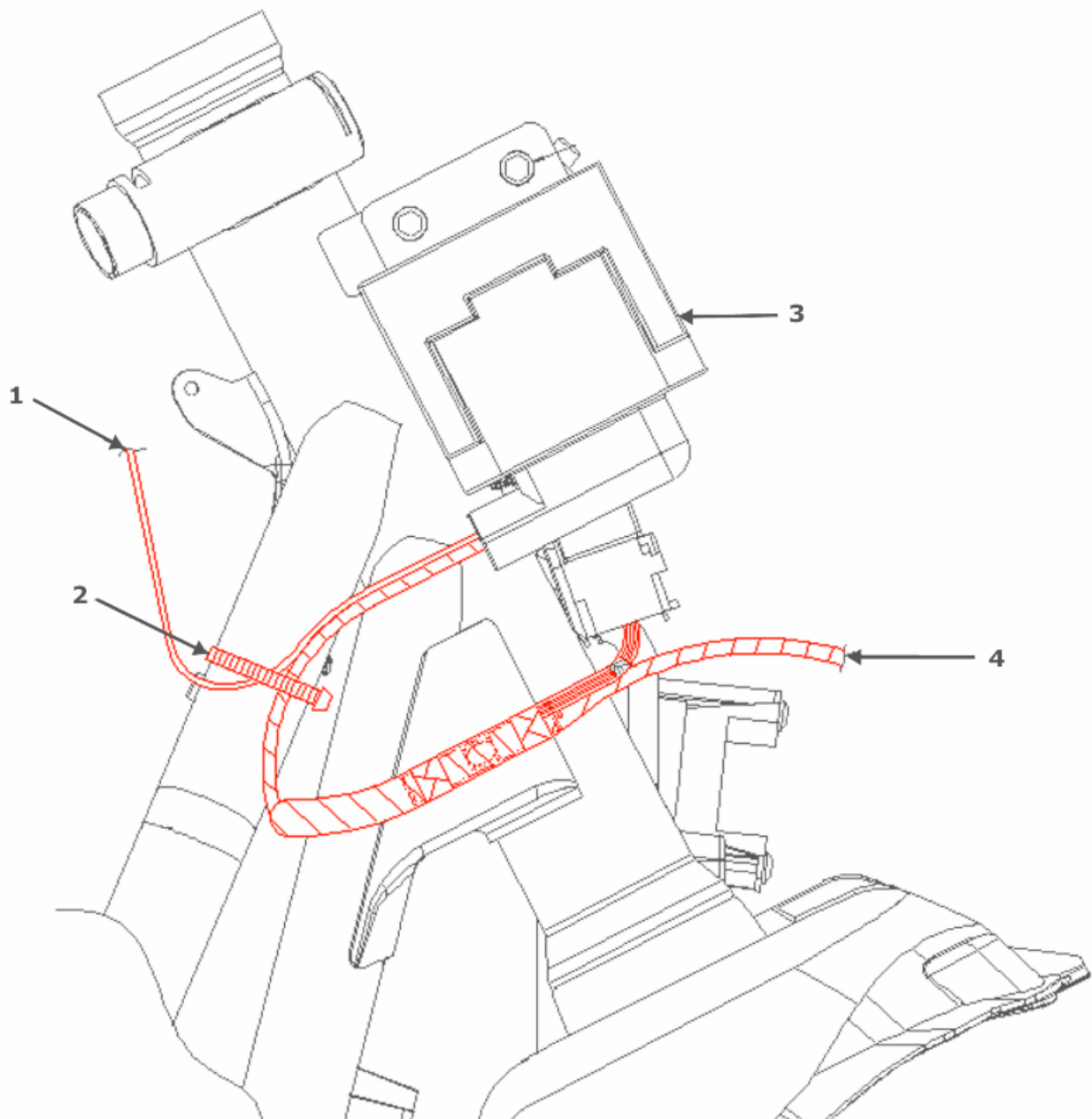

INSTALLING THE ELECTRICAL CIRCUIT

	Specification	Desc./Quantity
1	Installing the electrical circuit	To antenna
2	Installing the electrical circuit	Clamp
3	Installing the electrical circuit	Ignition master-box (ECU)
4	Installing the electrical circuit	To headlight

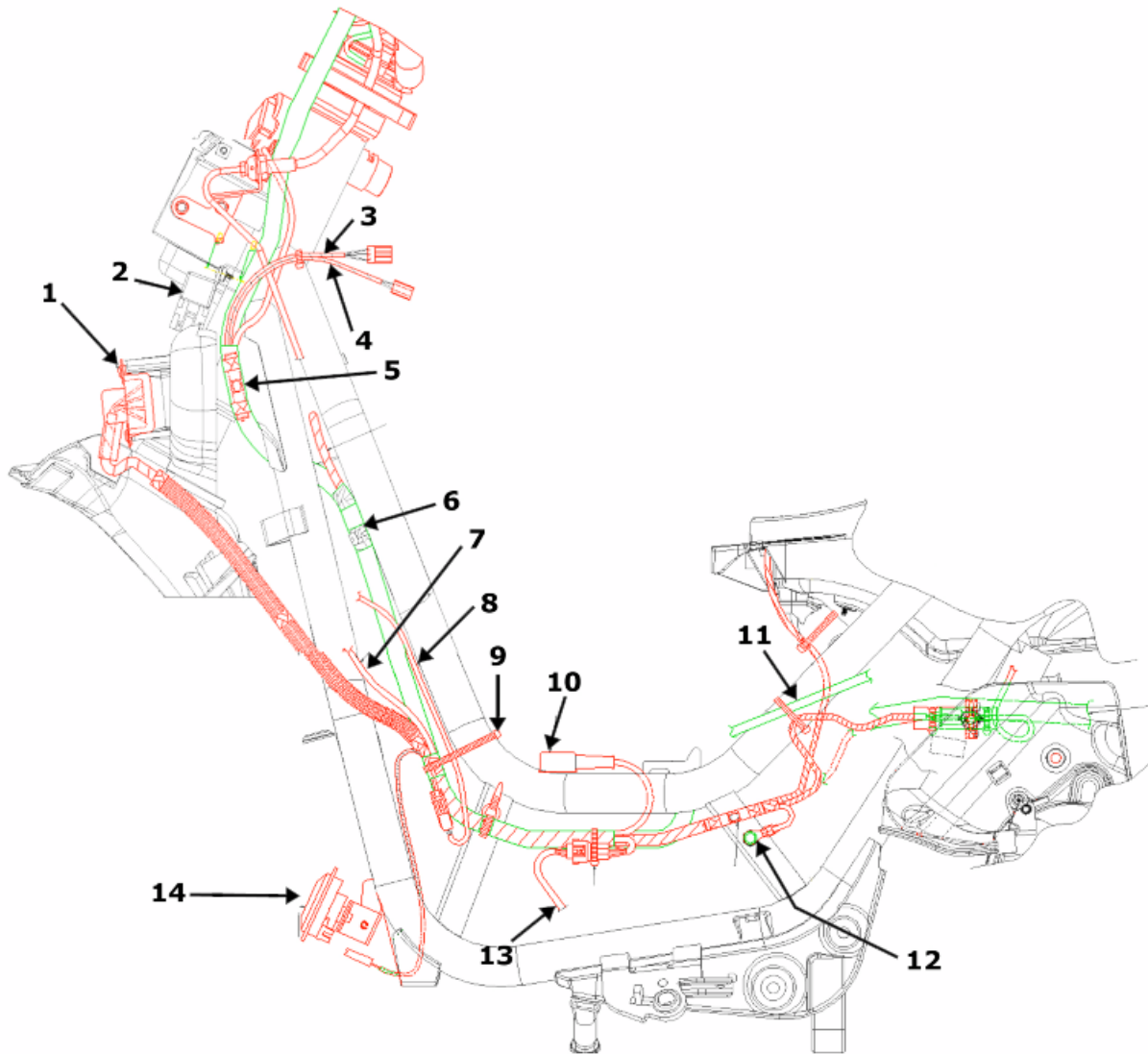

INSTALLING THE ELECTRICAL CIRCUIT

	Specification	Desc./Quantity
1	Installing the electrical circuit	Front fuse holder
2	Installing the electrical circuit	Two relays
3	Installing the electrical circuit	Intercom master-box pre-wiring
4	Installing the electrical circuit	To seat opening button
5	Installing the electrical circuit	Insert in the appropriate hole
6	Installing the electrical circuit	Insert in the appropriate hole
7	Installing the electrical circuit	To radiator thermal switch
8	Installing the electrical circuit	To electric fan

	Specification	Desc./Quantity
9	Installing the electrical circuit	Clamp
10	Installing the electrical circuit	To fuel level gauge
11	Installing the electrical circuit	Seat opening cable
12	Installing the electrical circuit	Earth cable fixing onto frame.
13	Installing the electrical circuit	To side-stand switch
14	Installing the electrical circuit	Horn

Back side

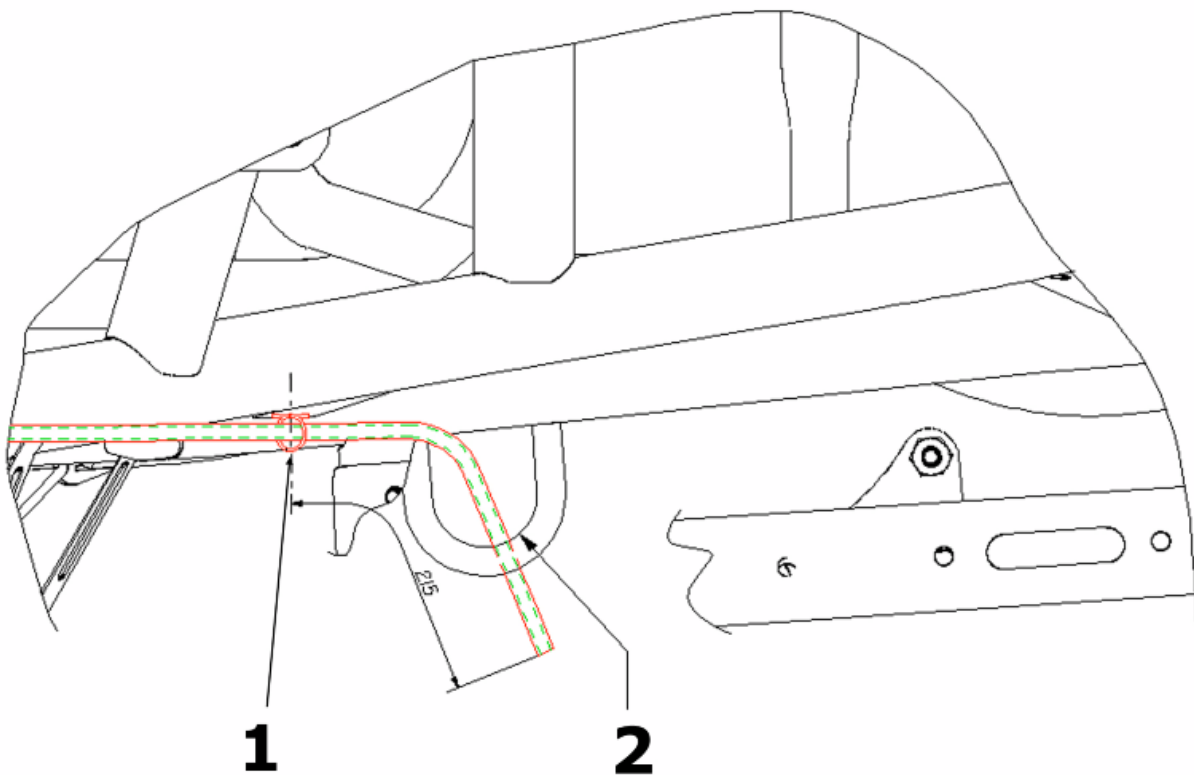

INSTALLING THE ELECTRICAL CIRCUIT

	Specification	Desc./Quantity
1	Installing the electrical circuit	Retaining spring
2	Installing the electrical circuit	Guide the battery breathing tube through the frame hole, as shown.

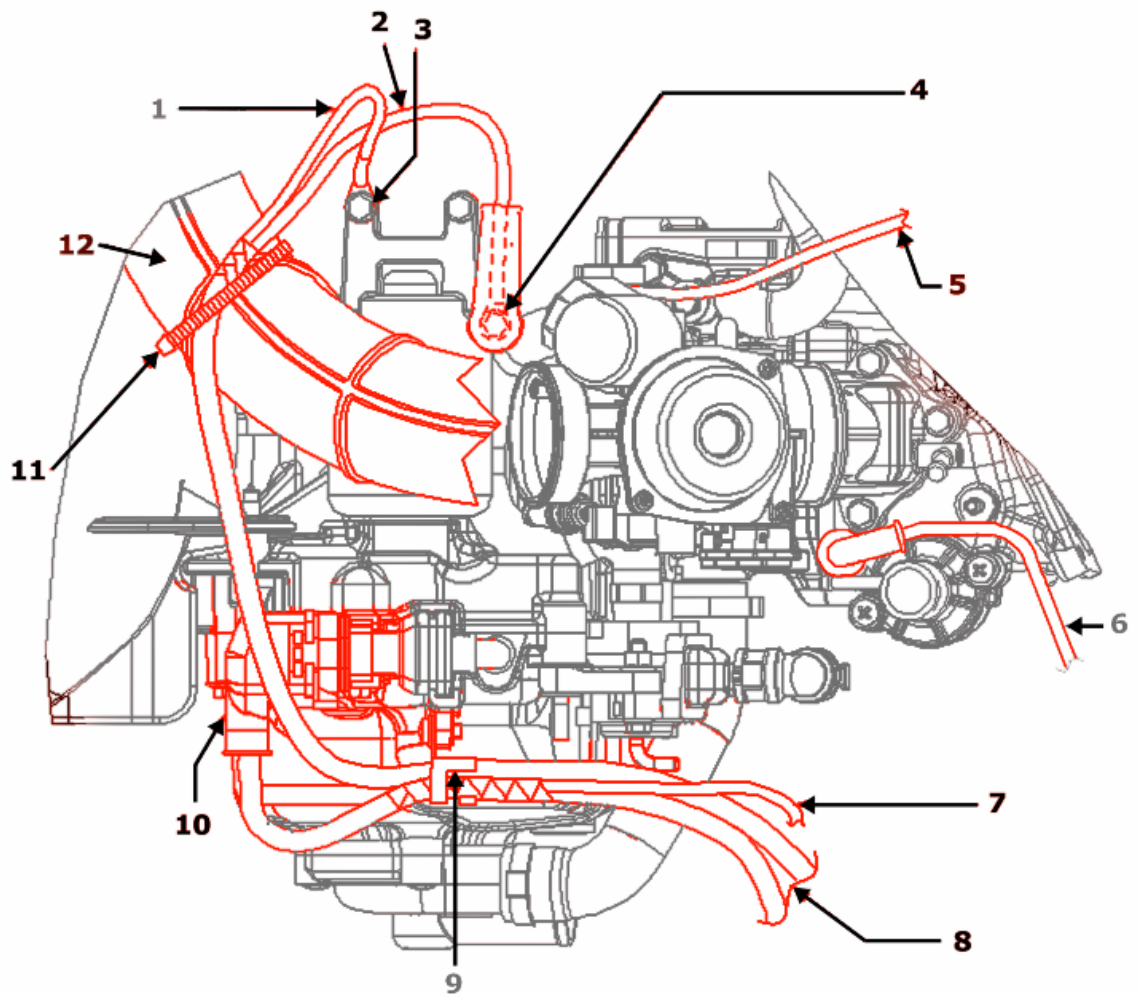

INSTALLING THE ELECTRICAL CIRCUIT

Specification	Desc./Quantity
1	Installing the electrical circuit Starter motor earth cable
2	Installing the electrical circuit Starter motor positive (+) cable
3	Installing the electrical circuit Screw - tighten up to 10 ÷ 13 Nm
4	Installing the electrical circuit Screw - tighten up to 6 ÷ 8 Nm
5	Installing the electrical circuit To automatic choke connection
6	Installing the electrical circuit Thermistor
7	Installing the electrical circuit To oil sensor
8	Installing the electrical circuit To cable harness
9	Installing the electrical circuit Metallic clamp
10	Installing the electrical circuit Flywheel connection
11	Installing the electrical circuit Clamp
12	Installing the electrical circuit Air filter/carburettor bellow

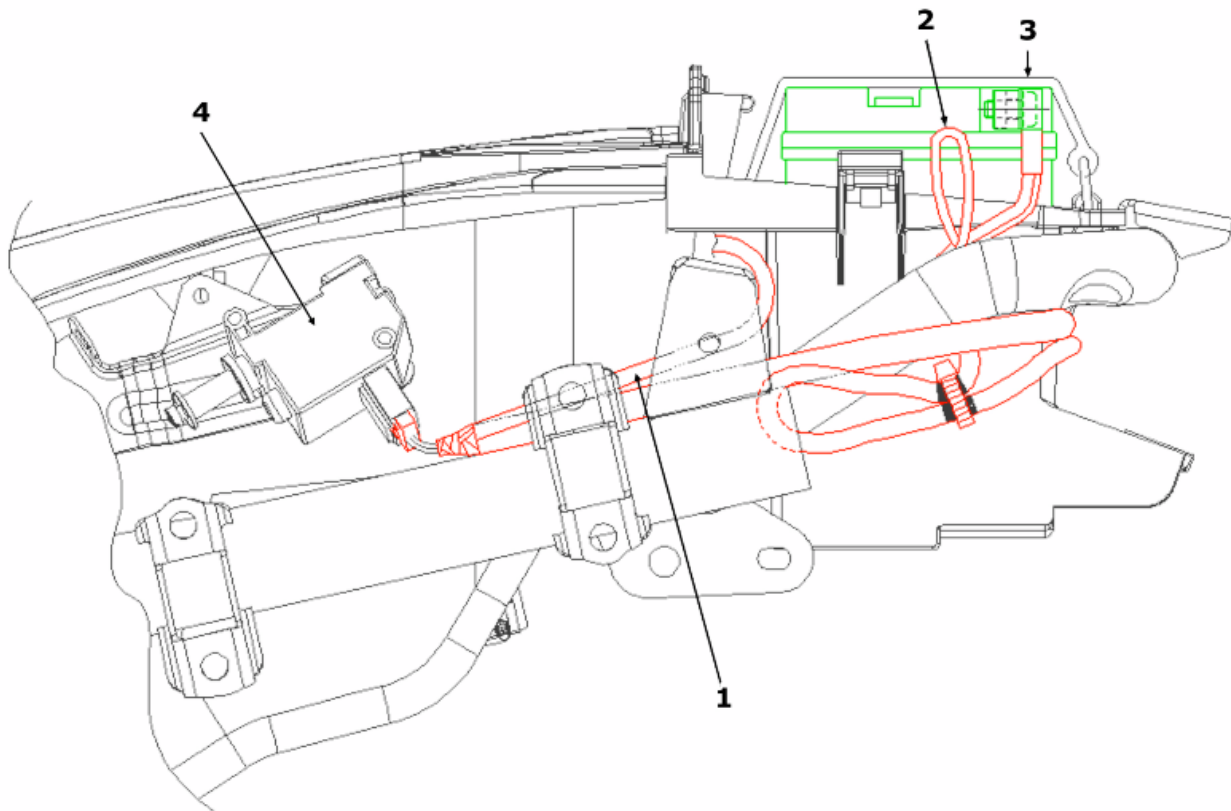

INSTALLING THE ELECTRICAL CIRCUIT

	Specification	Desc./Quantity
1	Installing the electrical circuit	To the plafoniera
2	Installing the electrical circuit	Choke device diagnostic port
3	Installing the electrical circuit	Battery restraining belt
4	Installing the electrical circuit	Seat opening actuator

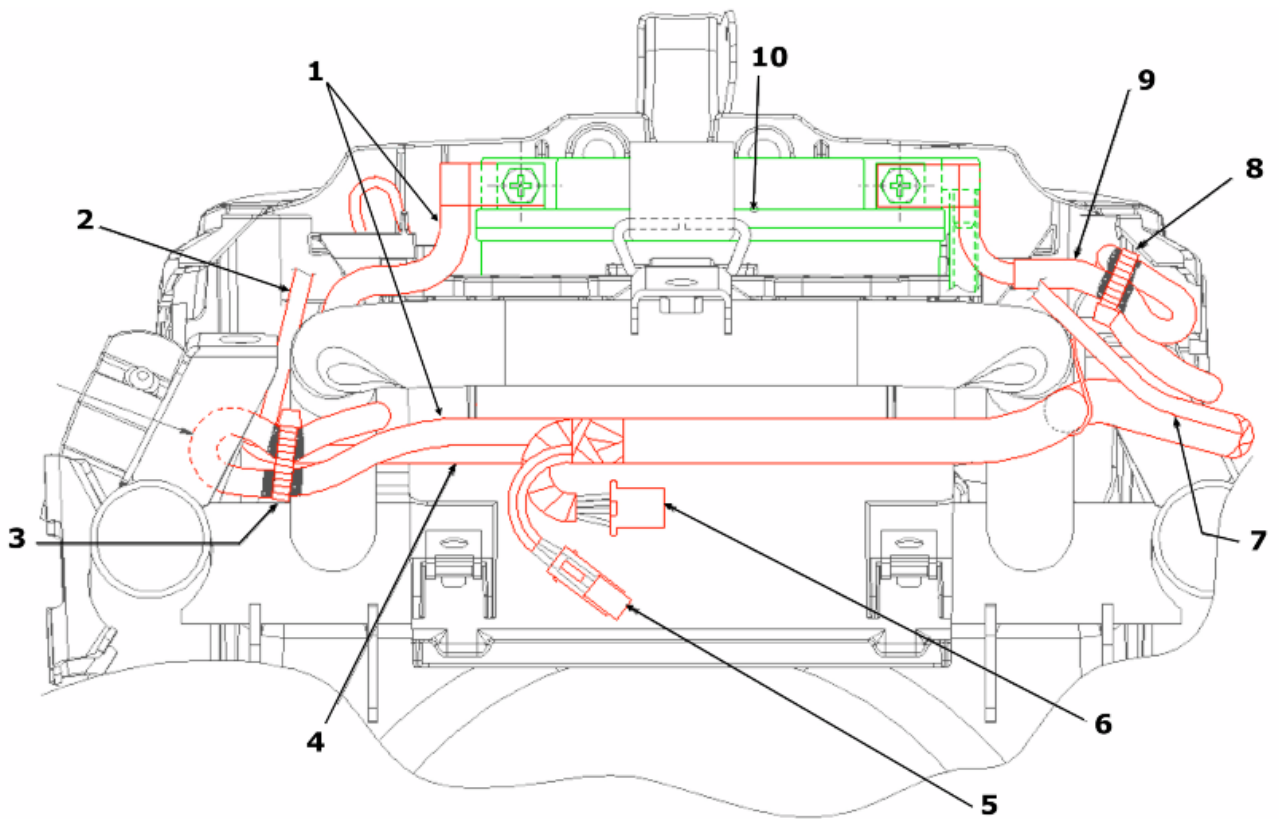

INSTALLING THE ELECTRICAL CIRCUIT

	Specification	Desc./Quantity
1	Installing the electrical circuit	To battery (-)
2	Installing the electrical circuit	To the plafoniera
3	Installing the electrical circuit	Clamp
4	Installing the electrical circuit	To actuator
5	Installing the electrical circuit	To license plate light
6	Installing the electrical circuit	To taillight
7	Installing the electrical circuit	To 12V - 180W power outlet underneath the seat
8	Installing the electrical circuit	Clamp
9	Installing the electrical circuit	To battery (+)
10	Installing the electrical circuit	Battery 12 V/12 Ah

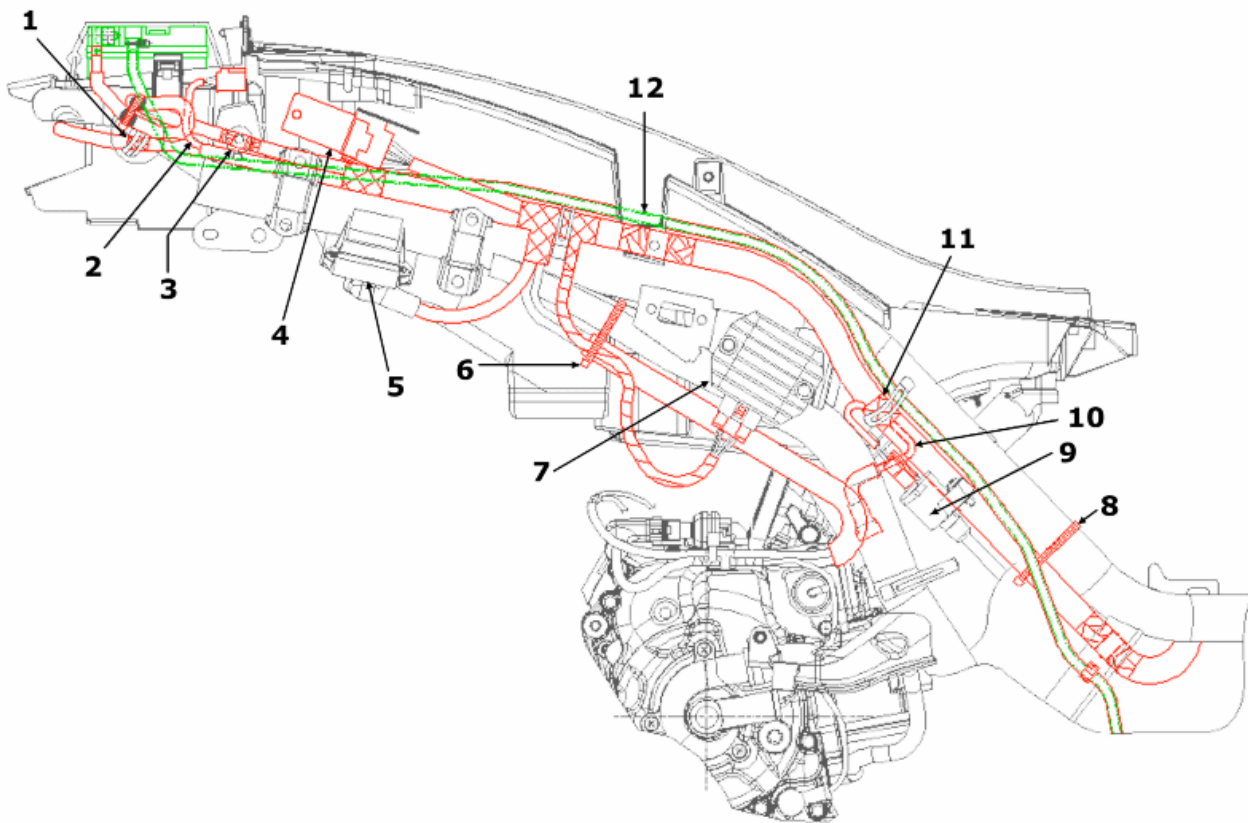

INSTALLING THE ELECTRICAL CIRCUIT

	Specification	Desc./Quantity
1	Installing the electrical circuit	Secure the metallic clamp on the red binding so that the cable harness remains underneath the frame tube.
2	Installing the electrical circuit	To 12V - 180W power outlet underneath the seat
3	installing the electrical circuit	The clamp must be placed on the aft hole
4	Installing the electrical circuit	Starter relay, 12V - 80A
5	Installing the electrical circuit	Rear fuse-holder
6	Installing the electrical circuit	Clamp
7	Installing the electrical circuit	Rear fuse-holder
8	Installing the electrical circuit	Clamp
9	Installing the electrical circuit	HT coil
10	Installing the electrical circuit	To thermistor
11	Installing the electrical circuit	Insert in the appropriate hole
12	Installing the electrical circuit	Battery breathing tube

Conceptual diagrams

Ignition

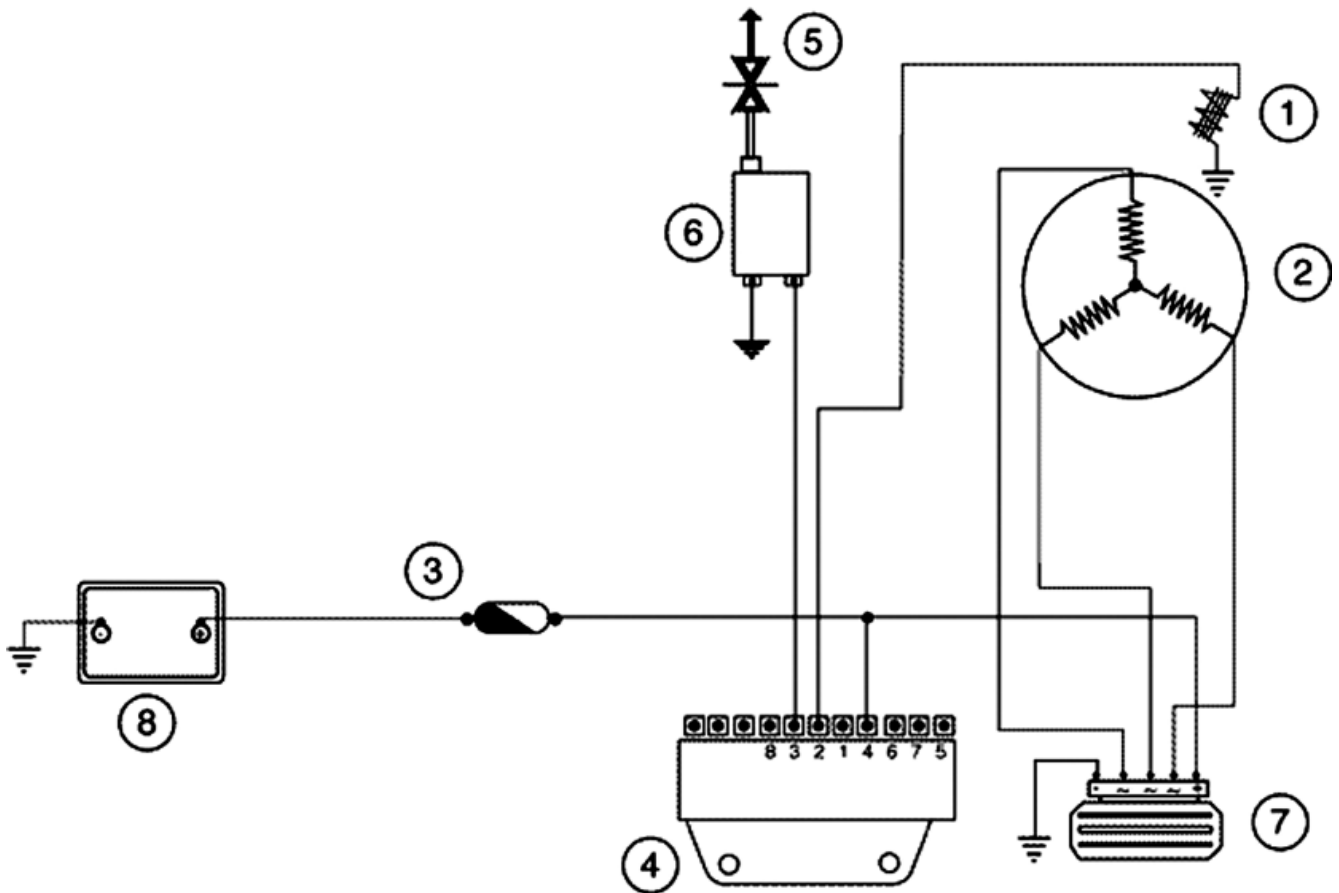

IGNITION

	Specification	Desc./Quantity
1	Pick - up	
2	Magneto flywheel	
3	Fuse	15A (N° 7)
4	Electronic ignition device	
5	Spark plug	
6	HV coil	
7	Voltage regulator	
8	Battery	12V - 10Ah

Headlights and automatic starter section

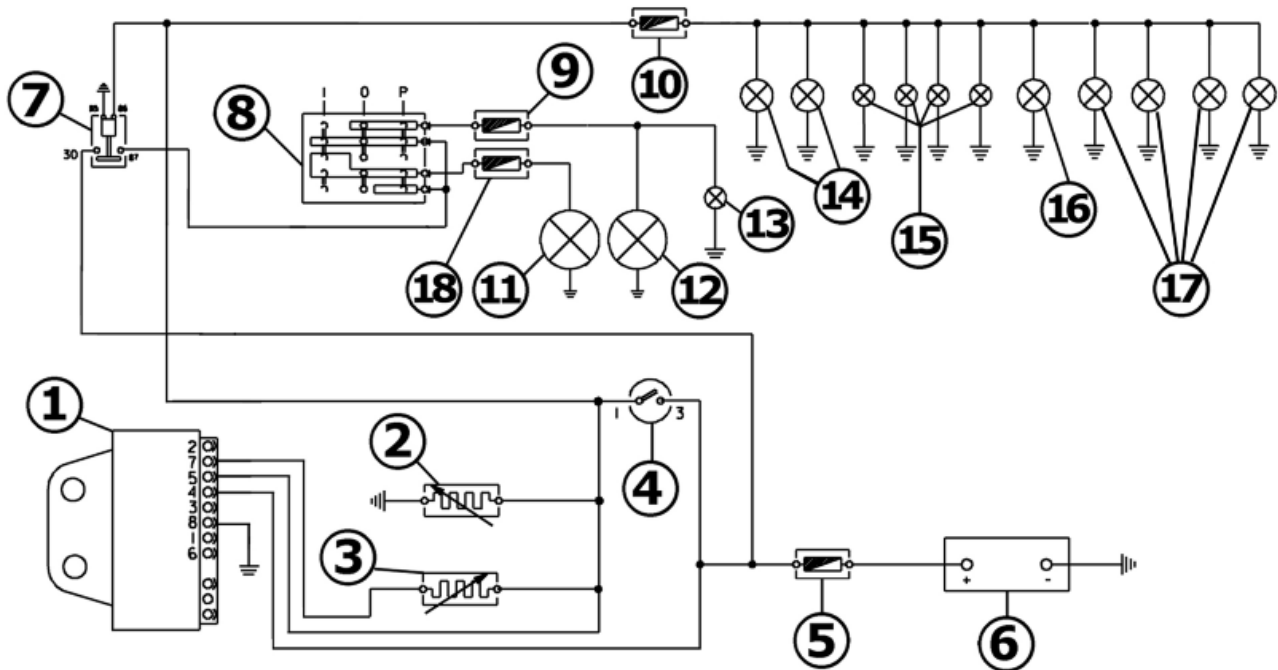

HEADLIGHTS AND AUTOMATIC STARTER SECTION

	Specification	Desc./Quantity
1	electronic control unit	
2	Carburettor heater	
3	Automatic starter	
4	Key switch	
5	Main fusible	15A
6	Battery	12V-9Ah
7	Headlamp relay	
8	Light switch	
9	High-beam fuse	7,5A
10	Low-beam and dashboard lights fuse	7,5A
11	Low-beam light bulb	12V - 55W
12	High-beam light bulb	12V-55W
13	High-beam lamp warning light	12V - 1.2W
14	Rear side light bulb	12V - 5W
15	Four dashboards illuminating bulbs	12V - 1,2W
16	License plate bulb	12V - 5W
17	Front side light bulb	12V - 5W
18	Low-beam fuse	7,5A

Battery recharge and starting

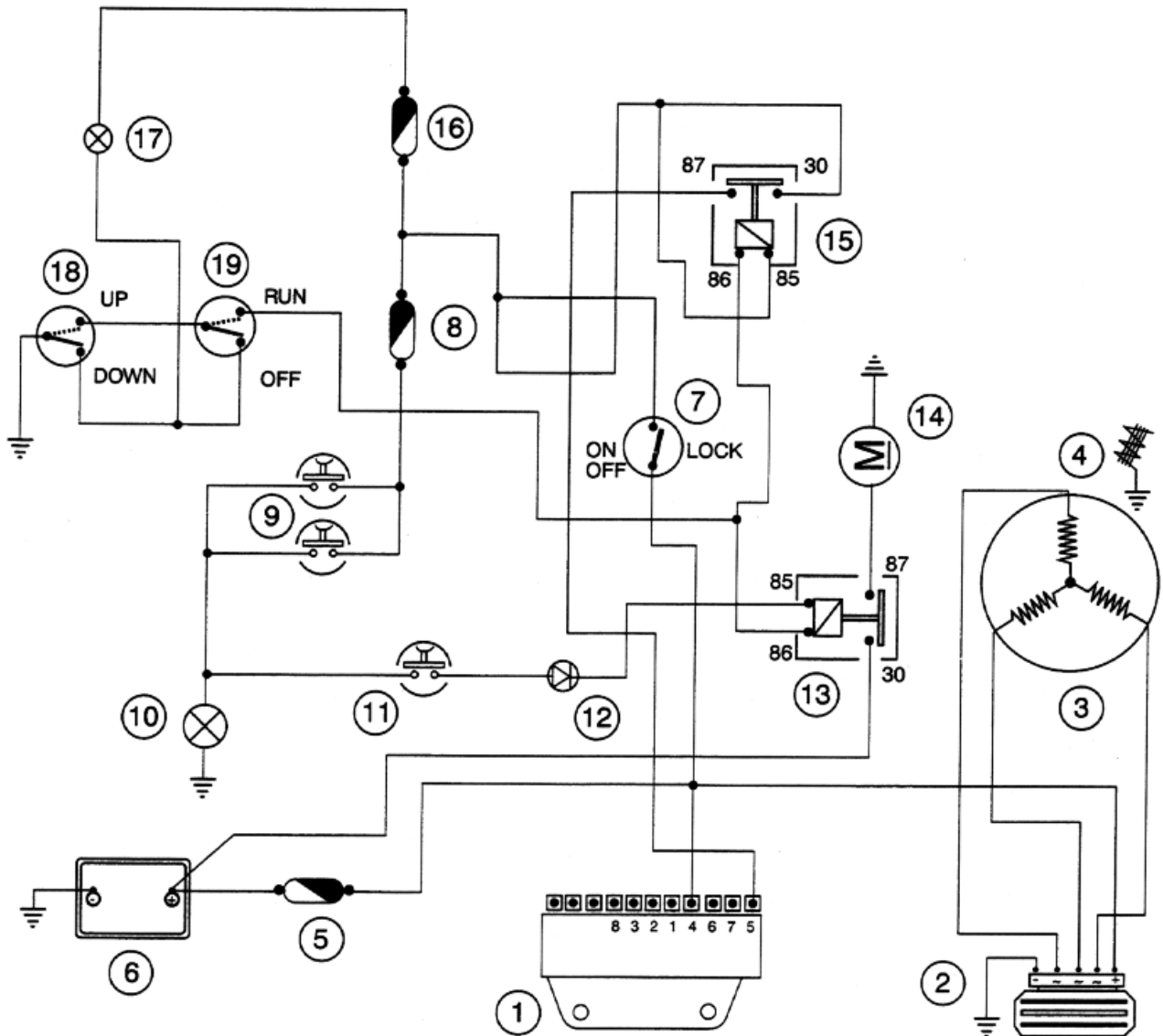

BATTERY RECHARGE AND START-UP

Specification	Desc./Quantity	
1	Electronic ignition device	
2	Voltage regulator	
3	Magneto flywheel	
4	Pick - up	
5	Fuse	15 A (N°7)
6	Battery	12V-12Ah
7	Key switch contacts	

	Specification	Desc./Quantity
8	Fuse	4A (N° 2)
9	Front and rear brake light button	
10	Brake light bulbs	12V-10W
11	Start up button	
12	Diodo	
13	Remote starter switch	
14	Starter motor	
15	Engine stop remote control switch	
16	Fuse	7,5A (N°1)
17	Engine disabled warning light bulb	12V - 1,2W
18	Side stand switch	
19	Engine stop switch	

Level indicators and enable signals section

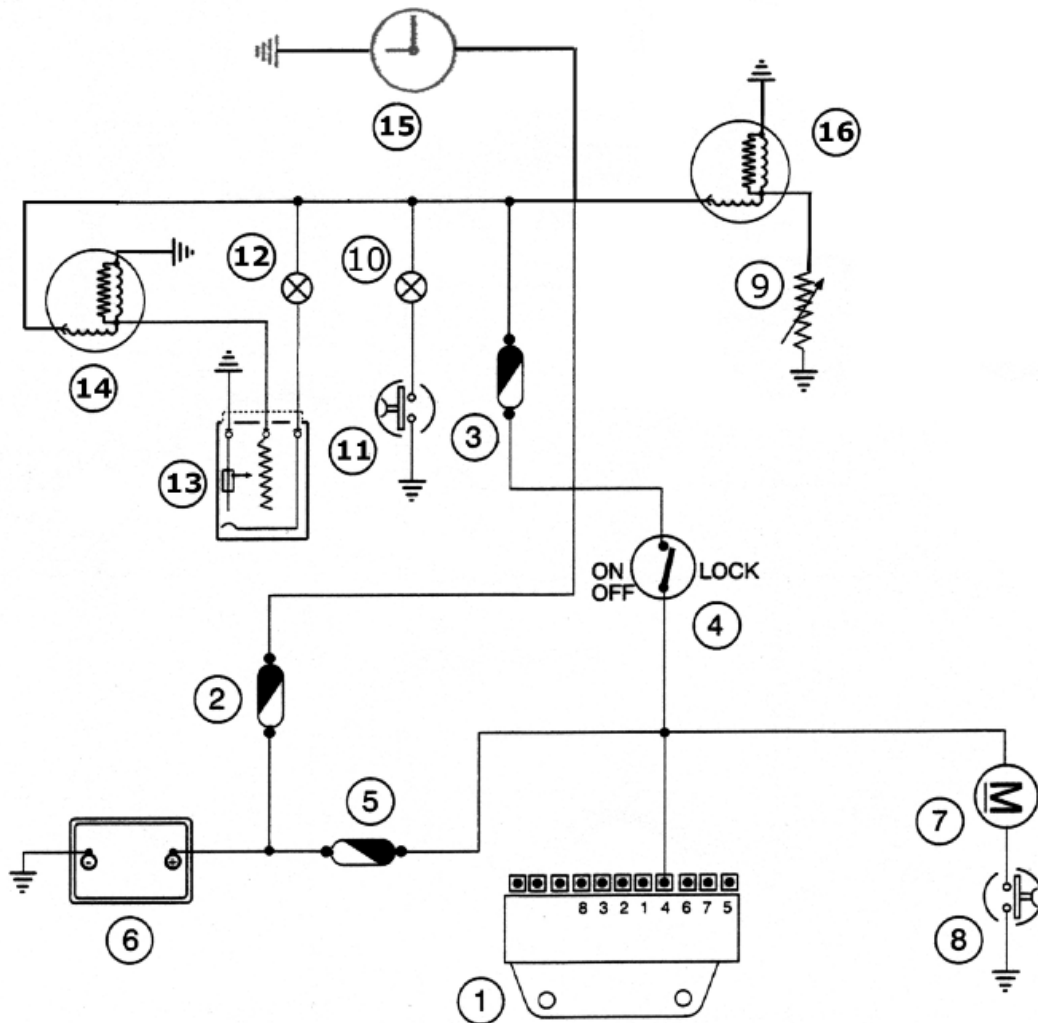

LEVEL INDICATORS AND ENABLE SIGNALS SECTION

	Specification	Desc./Quantity
1	Electronic ignition device	
2	Fuse	4A (N° 5)
3	Fuse	7,5A (N°1)
4	Key switch contacts	
5	Fuse	15 A (N°7)
6	Battery	12V-12Ah
7	Radiatore electric fan motor	

	Specification	Desc./Quantity
8	Thermal switch for electric fan	
9	Thermistor	
10	Oil Pressure Warning Light Bulb	12V - 1,2W
11	Motor Oil pressure sensor	
12	Reserve Fuel Warning Light Bulb	12V - 1,2W
13	Fuel level sender	
14	Fuel gauge	
15	Digital clock	
16	Coolant temperature gauge	

Thermal switch

We inform you that a new thermal switch has been introduced starting with frame number ZAPM2300003507739 (X9) ZAPM3620000003383 (X8) ZAPM2850000001025 (Beverly), in order to prevent possible malfunctioning of the thermal switch.

Turn signal lights

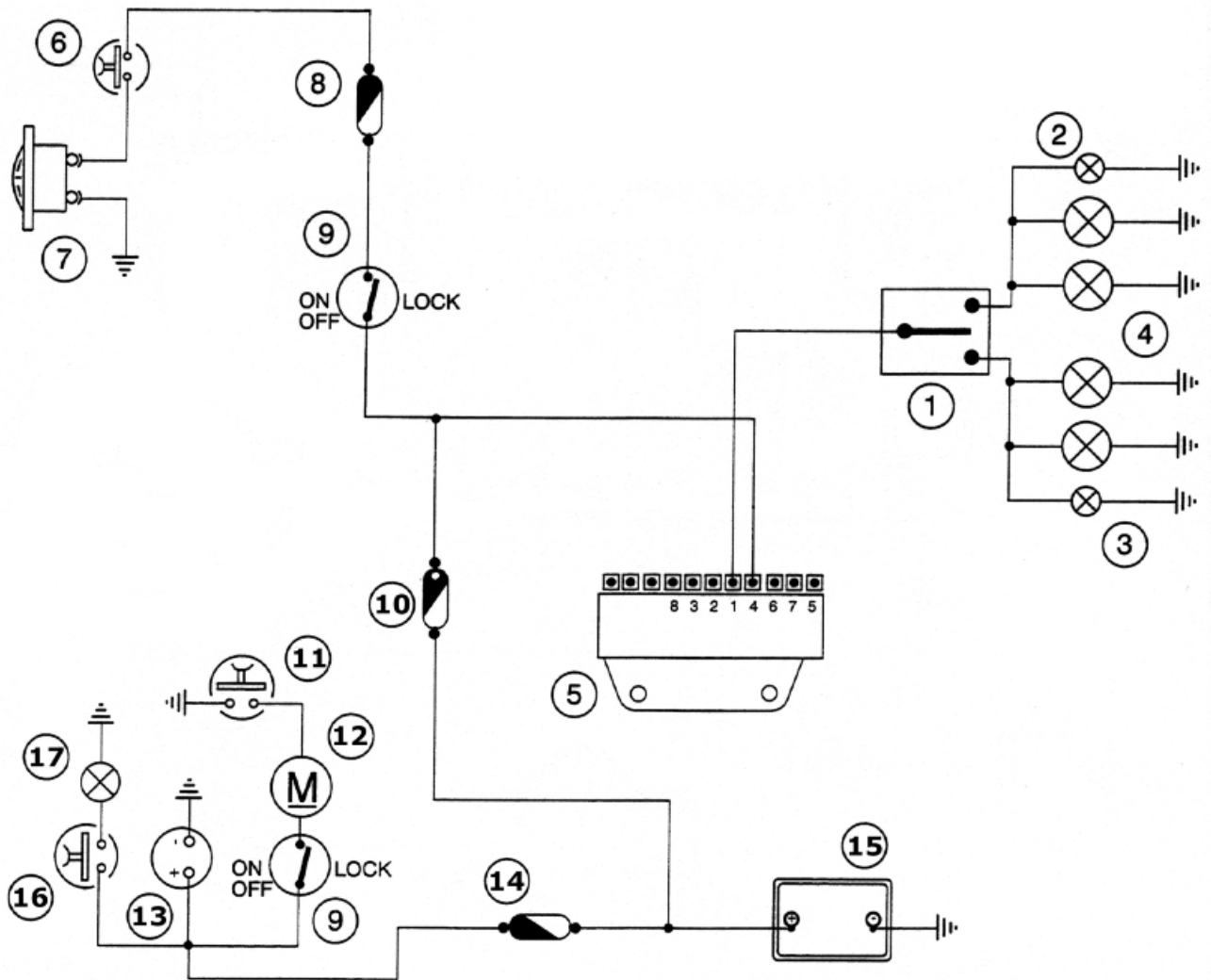

DIRECTION INDICATORS, HORN, UTILITIES

	Specification	Desc./Quantity
1	Turn indicator switch	
2	Rh turn indicator warning light bul	12V - 1,2W
3	Lh turn indicator warning light bulb	12V - 1,2W
4	Four turn indicator bulbs	N°4 12V-10W
5	Electronic ignition device	
6	Horn button	
7	Horn	12V
8	Fuse	7,5 A (N°3)

	Specification	Desc./Quantity
9	Key switch contacts	
10	Fuse	15 A (N°7)
11	Saddle electrical opening button	
12	Saddle opening actuator	
13	Plug socket	12 V - 180 W MAX
14	Fuse	15 A (N°8)
15	Battery	12V-12Ah
16	Helmet compartment lighting button	
17	Helmet compartment lamp bulb	12V-5W

Checks and inspections

Immobiliser

The electric ignition system is fed with direct current and is protected by an antitheft immobilizer integrated to the control unit.

The ignition system consists of:

- electronic control unit
- immobilizer aerial
- master and service keys with built-in transponder
- H.V. coil
- diagnosis LED

The diagnosis LED also works as a blinking light to deter theft. This function is activated every time the key switch is set to «**OFF**», when the side stand is lowered or the engine emergency cut-off switch is set to «**OFF**». It remains activated for 48 hours in order not to affect the battery charge.

When the ignition switch is turned to «**ON**», the deterring blinker function is deactivated. Subsequently, a flash confirms the switching to «**ON**».

The duration of the flash depends on the electronic control unit program (see figure).

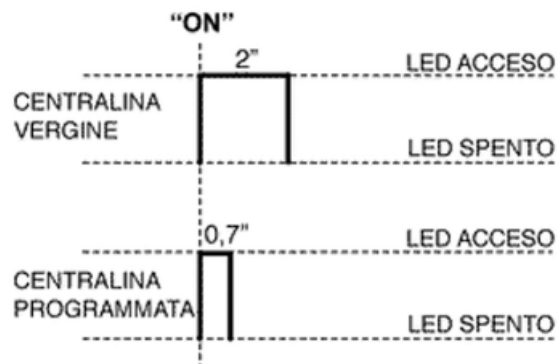

In case the LED turns off and remains so even when switching over to «ON», check if:

- there is battery voltage
- 15A main fuse (No. 7) is in working order.

If the deterring LED remains off, check the control unit power supply as follows:

- Disconnect the control unit connector. Check if:
 - There is battery voltage between terminal No. 4 (Red/Black) and the ground lead
 - There is battery voltage between the terminal No. 4 (Red/Black) and terminal No. 8 (Negative) as shown in the figure.

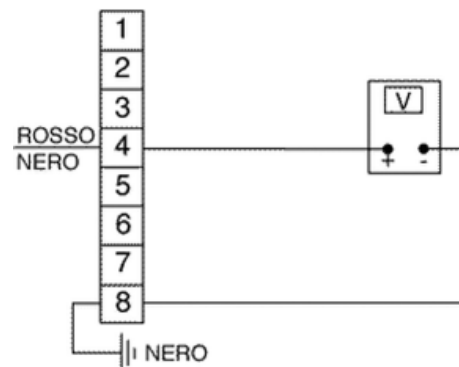
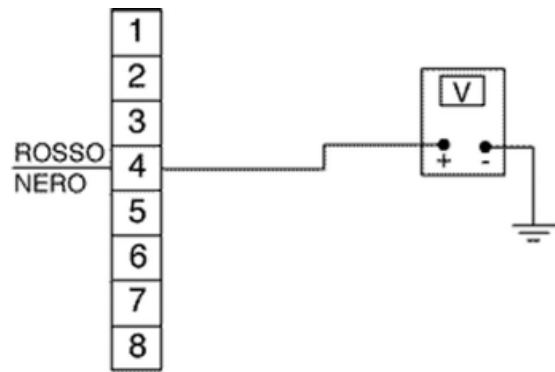

- There is battery voltage between the terminals No. 5 and No. 8 with the key switch set to «ON», the side stand folded up and the emergency cut-off switch set to «RUN».

If no faults are found, replace the control unit; otherwise, check the wiring and the following components:

- Engine stop remote control;
- Emergency cut-off switch;
- Side stand contacts;
- Key switch contacts.

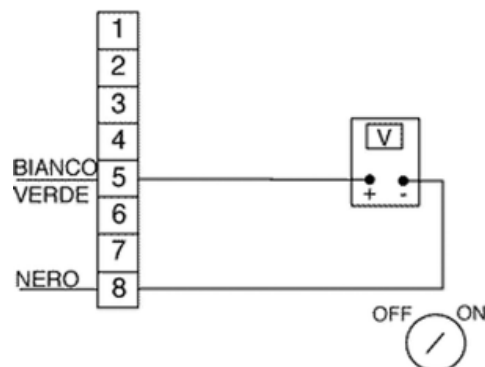

Virgin circuit

If the ignition system has not been programmed, the engine can be started but it will run limited to 2000 rpm. When trying to accelerate, some evident loss of power may be felt.

Program the system with the MASTER (Brown) and SERVICE (Black) keys as follows:

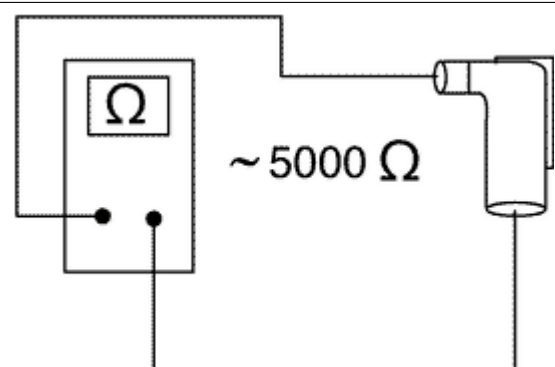

- Insert the MASTER key, turn it to "ON" and keep it in that position for 2 seconds (limit values: 1 ÷ 3 seconds).
- Alternately insert all the available black keys and turn each one of them to "ON" for 2 seconds.
- Insert the MASTER key again and turn it to "ON" for 2 seconds.

The maximum time to change keys is 10 seconds.

A maximum of 7 (Black) service keys can be programmed at one time.

Sequence and times must be strictly observed or it will be necessary to repeat the procedure from the start.

Once the control unit has been programmed, the control unit is inseparably matched with the MASTER key transponder.

This matching allows programming further service keys in case of loss, replacement, etc. Each new time new data is programmed the previously stored one is deleted.

If a service key setting is lost, it is essential to carefully check the efficiency of the high voltage system:

Shielded cap resistance ~ 5000 Ω.

In any case it is advisable to use resistive spark plugs.

Diagnostic codes

The flash indicating the switching to "ON" can be followed by a phase of programmed failure warnings. That is, the led is off for 2 seconds, and then diagnosis codes are transmitted with 0.5-second flashes. After the failure code indication, a steadily on LED signals that ignition is disabled; see the table:

Diagnostic code - 2 flashes

When the 2-flash code is detected, carry out the following checks:

- Check if the failure continues after changing key (MASTER key included). If the failure persists with any key, disconnect the aerial connector from the control unit and check the aerial for continuity with the recommended tool.

If non-conforming values are measured, replace the aerial.

If no failures are found in the aerial, replace the control unit.

CAUTION

BEFORE PROGRAMMING THE NEW ELECTRONIC CONTROL UNIT CHECK THAT NO FAILURE CODE IS INDICATED. THIS IS NECESSARY TO AVOID SPOILING A NEW CONTROL UNIT

Specific tooling

020331Y Digital multimeter

Electric characteristic

immobilizer aerial

~ 7 ÷ 9 Ohm

2-FLASH CODE - Example with programmed control unit, no transponder and/or malfunctioning aerial.

Ignition disabled-Vehicle immobilised

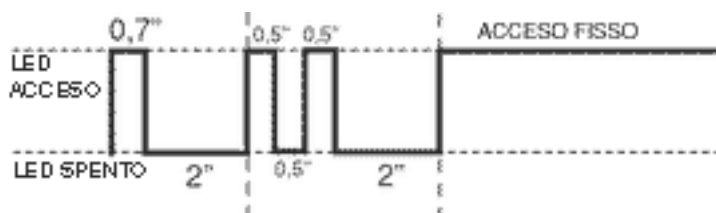

Diagnostic code - 3 flashes

If the 3-flash code is detected, check if the failure occurs when the MASTER key is inserted into the key switch.

- If the failure disappears when the MASTER key is used, proceed with coding a new service key (Blue).
- If the failure persists, it means that the MASTER key and the control unit are not linked; in this case, replace the control unit and then encode the keys.

The immobilizer system is efficient when, after switching over to «ON», only a 0.7-sec flash is detected (see diagram).

In this case, the engine can be started.

Example with programmed control unit, transponder, programmed key and working aerial. **The ignition is enabled (regular use conditions)**

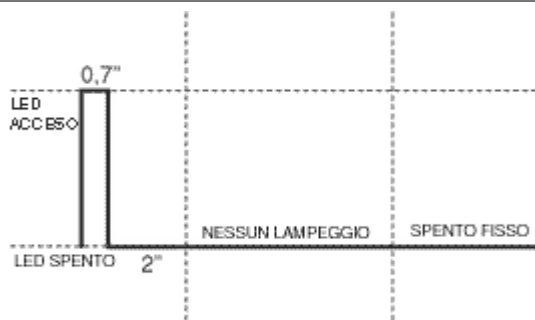

3-FLASH CODE - Example with programmed control unit, aerial working properly and unknown transponder code. **Ignition disabled-Vehicle immobilised**

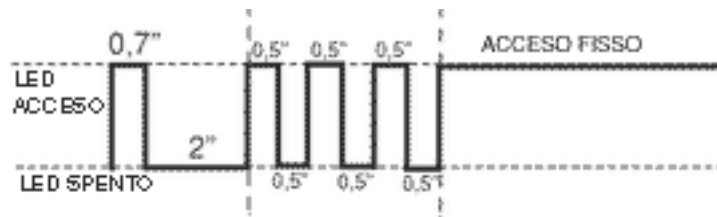

Ignition circuit

Once the immobilizer system is enabled, the HV coil and the signals from the Pick-Up will produce a spark in the spark plug.

The battery provides the basic power supply. The system is adjusted so that the start-up system immediately detects an eventual battery voltage drop, but this is practically irrelevant for the ignition system.

The Pick-Up is connected to the control unit by a single cable; then, for the ground circuit, the control unit is connected to the Pick-Up by the chassis and the engine ground lead.

To avoid disturbances in the ignition system during start-up, it is very important that the engine-chassis ground connection bonding is efficient.

No spark plug

Once the lack of power to the spark plug has been detected and the LED indicates it can be ignited, follow this procedure:

- Pick-Up check.

Disconnect the control unit connector and check the resistance value between terminal No. 2 (Green) and terminal No. 8 (Black). Check the Pick-Up and its power line:

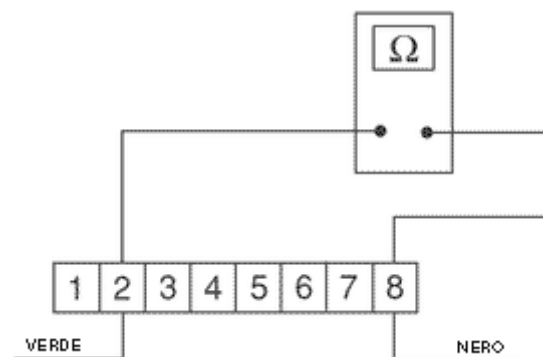

Electric characteristic

Pick-up resistance value

Pick-up resistance value: $105 \div 124 \text{ Ohm}$

If a break in the circuit is found, check again the flywheel and the engine ground connectors (see engine manual). If non-conforming values are measured, replace the Pick-Up; otherwise, repair the cable harness.

In case conforming values are measured, try replacing the control unit (without programming) and make sure the failure has been solved by checking sparks are produced in the spark plug; only then program the control unit.

- HV primary coil check

Disconnect the control unit connector and check that the cable between terminals No. 3 and No. 8 is not interrupted (see figure).

If non-conforming values are measured, check again the HV primary coil directly on the positive and negative terminals. If non-conforming values are measured, repair the cable harness or else replace the HV coil.

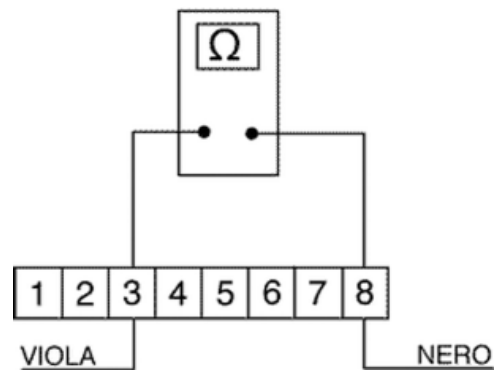

Electric characteristic

High voltage coil primary resistance value

High voltage coil primary resistance value: 0.4 ÷ 0.5 Ohm

HV coil secondary check

Disconnect the spark plug cap from the HV cable and measure the resistance between the HV cable terminal and the HV coil negative terminal (see figure).

If non-conforming values are measured, replace the HV coil. To carry out a more complete diagnosis, check the peak voltage with the multimeter adaptor.

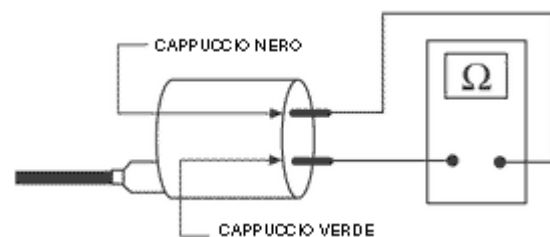

Electric characteristic

Resistance value

High voltage coil secondary resistance value ~ 2000 ± 300 ohm

Pick-Up.

- Disconnect the control unit connector and connect the positive wire to connector No. 2 and the negative wire to connector No. 8 (see figure).

- The multimeter end of a scale should be 200V.

Use the start-up system to run the engine and measure the voltage produced by the Pick-Up.

- Replace the Pick-Up if non-conforming values are measured.

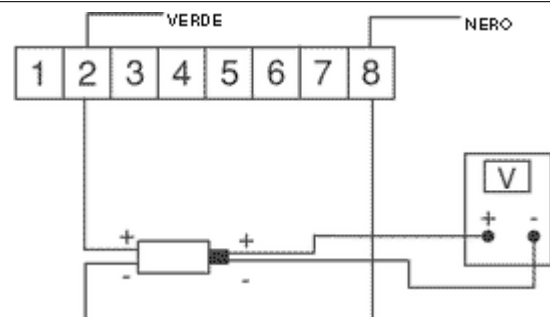

N.B.

THE MULTIMETER MUST BE SELECTED TO DETECT CONTINUOUS VOLTAGE.

Specific tooling

020409Y Multimeter adaptor - Peak voltage detection

Electric characteristic

Voltage value

> 5 Volt

- HV coil

With the control unit and HV coil connected, measure the voltage of the coil primary during the start-up test with the voltage peak adaptor and connecting the positive terminal to the ground one and the negative to the coil positive connector.

If non-conforming values are measured, replace the control unit.

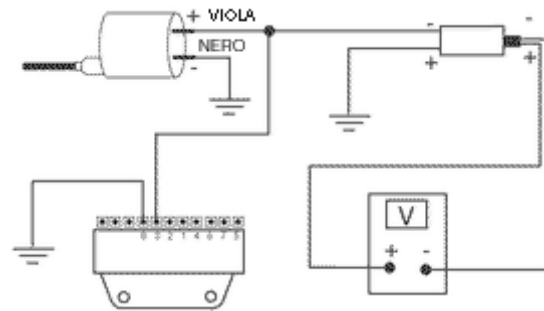

N.B.

THE PLASTIC CAP OF THE POSITIVE TERMINAL ON THE HV COIL PRIMARY IS BLACK AND THE NEGATIVE TERMINAL ONE IS GREEN.

Electric characteristic

High voltage coil voltage value

High voltage coil voltage value: > 100 Volt

Stator check

Disconnect the connector from the voltage regulator and check there is continuity between any yellow cable and the other two cables.

Electric characteristic

Ohm value:

0.7 ÷ 0.9 Ohm

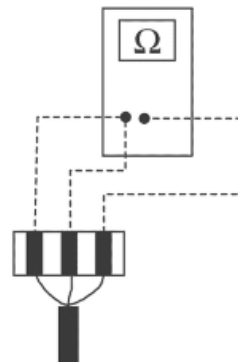

Also check that all yellow cables are insulated from the ground connection.

If non-conforming values are detected, repeat the checks directly to the stator. In case of further repetitions of incorrect values replace the stator or repair the wiring.

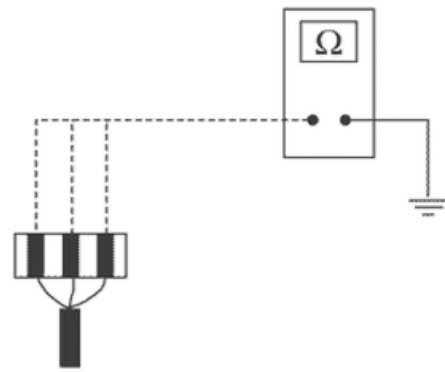

Voltage regulator check

With a perfectly charged battery and lights off, measure voltage at the battery poles with a high running engine.

The voltage should not exceed 15.2 Volt.

In case higher voltages are detected, replace the regulator.

In case of voltage values lower than 14 Volt, check the stator and the corresponding cable harness.

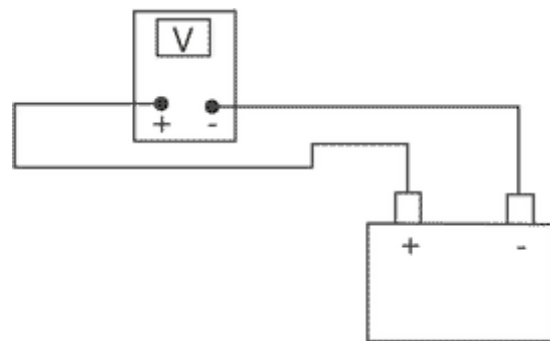

Recharge system voltage check

The recharge system is provided with a three phase alternator with permanent flywheel.

The alternator is directly connected to the voltage regulator.

In turn, the latter is directly connected to the ground lead and to the battery positive terminal passing through the 15A protection fuse (No. 7). This system therefore requires no connection to the key switch.

The three- phase generator provides good re-charge power and at low revs a good compromise is achieved between generated power and idle stability. For this reason, it is very important that the idle speed is adjusted as prescribed.

Connect an ammeter induction pliers to the voltage regulator positive terminal, measure the battery voltage and turning on the vehicles lights with

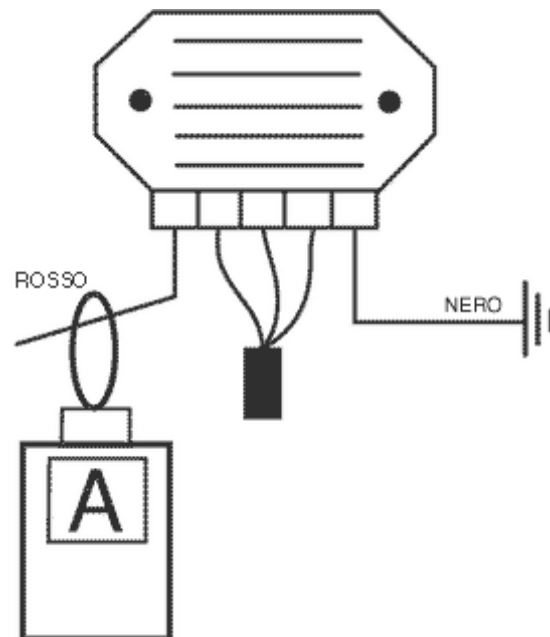

engine off, wait for the voltage to set at about 12 V. Start the engine and measure the current generated by the system with lights on and a high running engine.

In case the generated current value is lower than 10A, repeat the test using a new regulator and/ stator alternatively.

Choke Inspection

Refer to the engine section to check the resistance and operating conditions of the component. As regards voltage supply, keep the connector connected to the system and check that the two terminals receive battery voltage **with the engine on** (see figure).

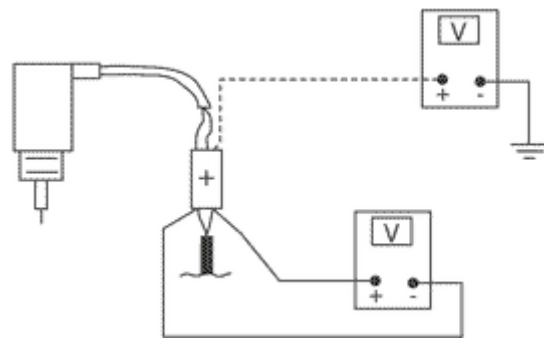

If there is no voltage, connect the multimeter's negative terminal to earth and the positive terminal to the white wire on the automatic choke device. With the ignition switch turned onto the «ON» position, check for the presence of battery voltage. If no voltage is detected, check the wiring connected with the ignition switch and the two fuses 15A (no. 8).

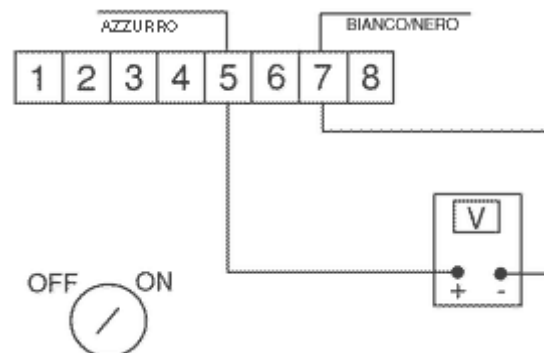

If voltage is present, repeat the check from the ignition control unit connector.

After disconnecting the choke device, start the engine and keep it idling. Check for the presence of voltage by connecting the multimeter's positive terminal to terminal no. 5 (white/green) and its negative terminal to terminal no. 7 (white/black) (see figure).

If no voltage is detected, replace the control unit after verifying the integrity of the fuses, otherwise check the wiring between the choke and the electronic control unit and if necessary proceed by replacing the choke device.

Turn signals system check

If the turn signal lights fail to operate, proceed as follows:

- Detach the control unit connector and check for potential difference at terminal no. 4 (red/black) with respect to earth (p.d. must be equal to battery voltage).
- Check that the same p.d. (battery voltage) is present between terminals no. 4 and no. 8 (black).
- Repeat the same check between terminals no. 5 (white/green) and no. 8 (black) with the ignition switch turned to the «ON» position, the side-stand retracted, and the emergency cut-off switch in the «RUN» position.

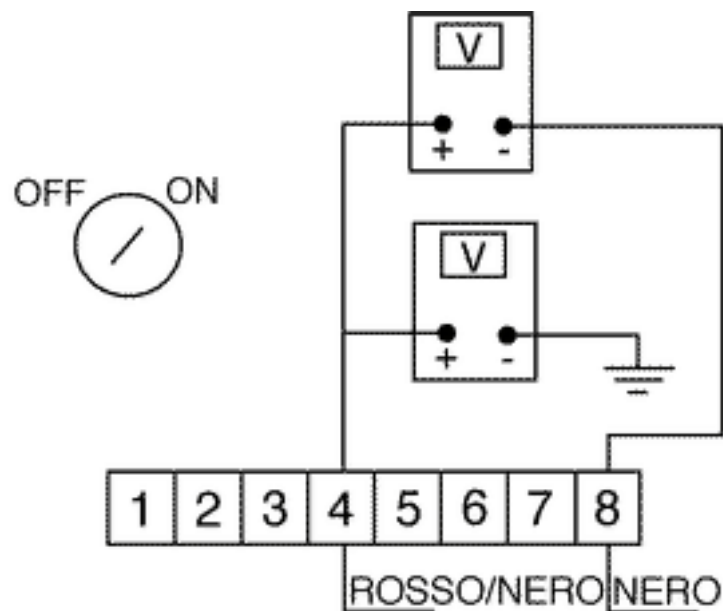

If no voltage is detected, check the wiring, the connections and the integrity of the main 15A fuse; otherwise proceed as follows:

- Use a jumper to connect terminals no. 1 (black/blue) and no. 4 (red/black) (see figure) and, operating the turn signal switch, alternating left and right hand-side, ensure that the turn signal lights light up.
- If so, the control unit is defective and must be replaced. Otherwise check the wiring between the control unit and the turn signal switch, and then repeat the test
- If the wiring is intact and the turn signal lights still fail to operate correctly, replace the turn signal switch.

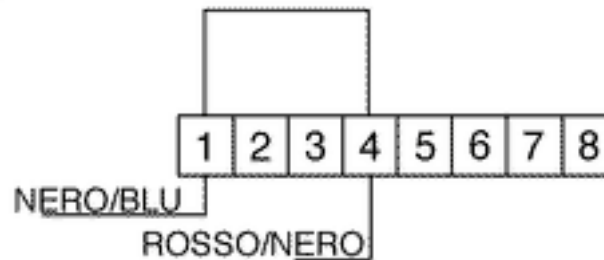

Lights list

LIGHT BULB TABLE

	Specification	Desc./Quantity
1	High-beam light bulb	Type: HALOGEN (H7) Power: 12V - 55W Quantity: 1
2	Low-beam bulb	Type: HALOGEN (H1) Power: 12V - 55W Quantity: 1
3	Front tail light bulb	Type: ALL GLASS Power: 12V - 5W Quantity: 2
4	Instrument panel bulb	Type: ALL GLASS Power: 12V - 2W Quantity: 5
5	Front turn indicator bulb	Type: Spherical Power: 12V - 10W Quantity: 1 RHS + 1 LHS
6	Helmet compartment light bulb	Type: CYLINDRIC Power: 12V - 5W Quantity: 1
7	Rear turn indicator light bulb	Type: Spherical Power: 12V - 10W Quantity: 1 RHS + 1 LHS
8	Taillight bulb	Type: SPHERICAL Power: 12V - 3W Quantity: 2
9	Stop light bulb	Type: ALL GLASS Power: 12V - 10W Quantity: 1
10	License plate light bulb	Type: ALL GLASS Power: 12V - 5W Quantity: 1

Fuses

The electrical equipment is protected by:

1. Four fuses "A" protecting the outside electrical socket, located under the right-hand side panel.
2. Four fuses "B" protecting the different circuits, located in the upper left portion of the glove compartment.

The tables show the positions and specifications of the fuses installed on the vehicle.

CAUTION

BEFORE REPLACING A BLOWN FUSE, FIND AND SOLVE THE FAILURE THAT CAUSED IT TO BLOW. NEVER TRY TO REPLACE THE FUSE USING ANY OTHER MATERIAL (A PIECE OF ELECTRICAL WIRE, FOR EXAMPLE) OR A FUSE OF A DIFFERENT RATING THAN THAT SPECIFIED.



FUSES A

	Specification	Desc./Quantity
1	Diagnostic LED, Clock	N.1 4A
2	Headlight (high/low beam bulb)	N.1 10A
3	General	N.1 15A
4	Helmet compartment lamp, 12V socket, saddle electrical opening actuator	N.1 15A

FUSES B

	Specification	Desc./Quantity
1	Electric stand prewiring, starter relay switch coil, engine stop relay coil, engine disabled warning light, oil pressure warning light, reserve fuel warning light, coolant temperature warning light	N.1 7,5A
2	Brake light bulb, starter relay switch inhibitor	N.1 4A
3	Horn, passing function	N.1 7,5A
4	Analogue instrument panel light bulbs, number-plate light bulb, front and rear parking light bulbs	N.1 4A

Sealed battery

If the vehicle is provided with a sealed battery, the only maintenance required is the check of its charge and recharging, if necessary.

These operations should be carried out before delivering the vehicle, and on a six-month basis while the vehicle is stored in open circuit.

Besides, upon pre-delivery it is therefore necessary to check the battery charge and recharge it, if required, before storing the vehicle and, afterwards, every six months.

INSTRUCTIONS FOR THE BATTERY REFRESH AFTER OPEN-CIRCUIT STORAGE

1) Voltage check

Before installing the battery on the vehicle, check the open circuit voltage with a regular tester.

- If voltage exceeds 12.60 V, the battery can be installed without any renewal recharge.
- If voltage is below 12.60 V, a renewal recharge is required as explained in 2).

2) Constant voltage battery charge mode

- Constant voltage charge equal to 14.40 ÷ 14.70V
- Initial charge voltage equal to 0.3 ÷ 0.5 for Nominal capacity
- Charge time:
10 to 12 h recommended
Minimum 6 h
Maximum 24 h

3) Constant current battery charge mode

- Charge current equal to 1/10 of the nominal capacity of the battery
- Charge time: 5 h

CAUTION

NEVER USE FUSES WITH A CAPACITY HIGHER THAN THE RECOMMENDED CAPACITY. USING A FUSE OF UNSUITABLE RATING MAY SERIOUSLY DAMAGE THE VEHICLE OR EVEN CAUSE A FIRE.

CHARGE THE BATTERY BEFORE USE TO ENSURE OPTIMUM PERFORMANCE. INADEQUATE CHARGING OF THE BATTERY WITH A LOW ELECTROLYTE LEVEL BEFORE IT IS FIRST USED SHORTENS THE LIFE OF THE BATTERY.

IF THE VEHICLE IS NOT USED FOR SOME TIME (1 MONTH OR MORE) THE BATTERY NEEDS TO BE RECHARGED PERIODICALLY. THE BATTERY RUNS DOWN COMPLETELY IN THE COURSE OF THREE MONTHS. IF IT IS NECESSARY TO REFIT THE BATTERY IN THE VEHICLE, BE CAREFUL NOT TO REVERSE THE CONNECTIONS TAKING INTO ACCOUNT THAT THE GROUND WIRE (BLACK) MARKED(-) MUST BE CONNECTED TO THE - NEGATIVE TERMINAL WHILE THE OTHER TWO RED WIRES MARKED (+) MUST BE CONNECTED TO THE TERMINAL MARKED WITH THE +POSITIVE SIGN

WARNING

WHEN THE BATTERY IS REALLY FLAT (WELL BELOW 12.6V) IT MIGHT OCCUR THAT 5 HOURS OF RECHARGING ARE NOT ENOUGH TO ACHIEVE OPTIMAL PERFORMANCE. GIVEN THESE CONDITIONS IT IS HOWEVER ESSENTIAL NOT TO EXCEED 8 HOURS OF CONTINUOUS RECHARGING SO AS NOT TO DAMAGE THE BATTERY ITSELF.

The battery should always be kept clean, especially on its top side, and the terminals should be coated with Vaseline.

Normal bench charging must be carried out using the specific battery charger 020333Y (single) or 020334 (multiple), setting the battery charge selector to the type of battery that needs recharging (i.e., at a current equal to 1/10 of the battery rated capacity). Connections to the power supply source must be implemented by connecting corresponding poles (+ to + and - to -).

Dry-charge battery

COMMISSIONING A NEW DRY-CHARGED BATTERY

- Remove the battery air pipe stop cap and each single element caps.
- Fill the battery with electrolyte of 1.270+/-0.01 kg/l density (corresponding to 31+/-1 Bé) with an ambient temperature not below 15°C, until it reaches the upper level indicated on the block.
- Tilt the battery slightly to remove any air bubbles formed during filling.
- Place the caps on each single element filling holes without screwing them and leave the battery to rest. During this stage, the battery is subjected to a gasification phenomenon and temperature increases.
- Let it rest until it reaches ambient temperature (this stage can take up to 60 minutes).
- Tilt the battery slightly to facilitate the elimination of any gas bubbles present inside; restore the level using the same filling electrolyte

Note: This is the last time that electrolyte can be added. Future top-ups should be done only with distilled water;

- Before 24 hours elapse, recharge the battery following these steps:
- Connect the battery charger terminals observing the correct polarity;
- With the battery charger drw. 020333Y and/or drw. 020334Y operate the battery charger control by selecting the position corresponding to that capacity;
- Otherwise, charge the battery with direct current equal to 1/10 of rated capacity (e.g. for a battery with a 9Ah rated capacity, the charging current should be 0.9-1.0A) for approximately a 4-6 hour charge.

Note: Batteries that have been stored for a long time may take a longer charging time. The battery chargers drw. 020333Y and drw. 020334Y have an automatic protection which interrupts the recharge after 12 hours to avoid battery harmful heating. In this case, a green LED turns on to indicate the activation of the safety system and not the end of the charge.

- Let the open circuit battery rest for approximately 4-6 hours; then check the off-load voltage using a standard tester.
- If the open-circuit voltage is higher or equal to **12.6V**, the battery is charged adequately. Slightly shake or tilt the battery to eliminate any air bubbles formed during recharging.
- Check the electrolyte levels again, fill them with distilled water up to the upper level line if necessary, clean battery properly, close each single cell cap tightly and install it on the vehicle.
- If the voltage indicated is low, charge the battery another 4-6 hours in the way described above.

Note: With the battery charger drw. 020334Y, it is possible to check the battery charge level with the **Check** function. The value indicated on the display must be higher than the value indicated on the chart; otherwise, recharge the battery again in the same way indicated above.

INDEX OF TOPICS

ENGINE FROM VEHICLE

ENG VE

Exhaust assy. Removal

- Undo the two exhaust manifold fixings on the head.

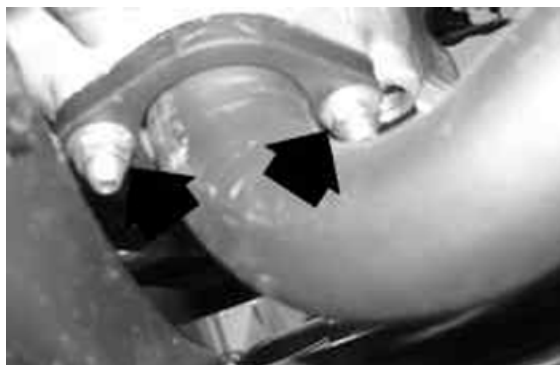

- Undo the three screws fixing the muffler to the support arm.
- Remove the full muffler unit.

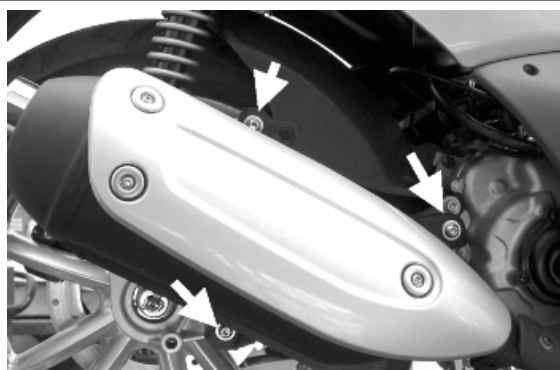

To refit, carry out the removal operations in reverse order, observing the prescribed tightening torques.

Locking torques (N*m)

Nuts fixing muffler to support arm 27 ÷ 30 Nut fixing muffler to cylinder head 16 ÷ 18

Removal of the engine from the vehicle

- Disconnect the battery.
- Remove seat, side fairings, and footrests.
- Drain coolant.
- Remove the silencer assembly.
- Remove the silencer mounting bracket.
- Remove the rear wheel.
- Remove the shock-absorbers lower fixings.
- Remove the throttle cable.
- Detach the air filter bellow and manifold shown in the figure.
- Detach engine earth cable.
- Disconnect the electrical devices on the carburettor and the starter motor power cord.



- Detach the inlet and outlet carburettor fuel lines and the cooling circuit hoses (head outlet and thermostat inlet).
- Remove the canister safety valve vacuum hose.
- Detach the spark plug H.T. cable.
- Detach the generator wiring from the vehicle's electrical circuit.
- Remove the swing-arm from the engine pivoting.
- The engine may now be removed.

WARNING

CARRY OUT THESE OPERATIONS WHEN THE ENGINE IS COLD

WARNING

BE VERY CAREFUL WHEN HANDLING FUEL.

CAUTION

WHEN INSTALLING THE BATTERY, ATTACH THE POSITIVE LEAD FIRST AND THEN THE NEGATIVE LEAD.

- When refitting the engine on the scooter, carry out the removal operations but in reverse order and respect the locking torques indicated in the Characteristics Chapter.
- Check the engine oil level and if necessary top it up with the recommended type.
- Top-up the cooling circuit.
- Check the functioning of the accelerator and the electrical devices.

CAUTION

PAY PARTICULAR ATTENTION TO POSITIONING THE THROTTLE CONTROL TRANSMISSION PROPERLY. CHECK THAT THERE IS A SMALL CLEARANCE WHEN THE VALVE IS IN ABUTMENT AGAINST THE SET SCREW.

See also

[Removal](#)
[Removing the rear wheel](#)
[Seat](#)
[Exhaust assy. Removal](#)
[Side fairings](#)
[Footrest](#)
[Swing-arm](#)

INDEX OF TOPICS

ENGINE

ENG

Automatic transmission

Transmission cover

- To remove the transmission cover it is necessary to remove the plastic cover first, by inserting a screwdriver in the slotted holes. Using the clutch bell lock wrench shown in the figure, remove the driven pulley shaft locking nut and washer.



Specific tooling

020423Y driven pulley lock wrench

- Remove the cap/dipstick from the engine oil filling hole.

- Remove the ten screws.

- Remove the transmission cover.

If this operation is carried out directly on the vehicle, remove the cooling air supply coupling of the transmission housing.



Air duct

- Remove the transmission compartment air intake cover shown in the photograph.

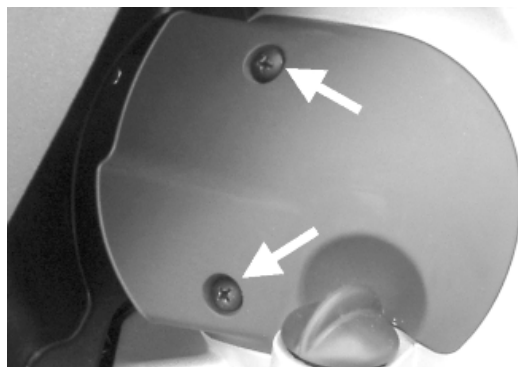

Removing the driven pulley shaft bearing

- Remove the clip from the inside of the cover.
- Remove the bearing from the crankcase by means of:

Specific tooling

020376Y Adaptor handle

020375Y Adaptor 28 x 30 mm

020412Y 15 mm guide

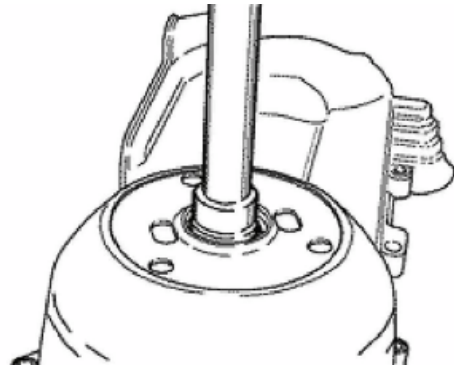

Refitting the driven pulley shaft bearing

- Slightly heat the crankcase from the inside so as not to damage the painted surface.
- Insert the bearing in its seat.
- Refit the Seeger ring.

CAUTION

USE AN APPROPRIATE REST SURFACE TO AVOID DAMAGING THE COVER PAINT.

N.B.

ALWAYS REPLACE THE BEARING WITH A NEW ONE UPON REFITTING.

Specific tooling

020376Y Adaptor handle

020357Y 32 x 35 mm adaptor

020412Y 15 mm guide

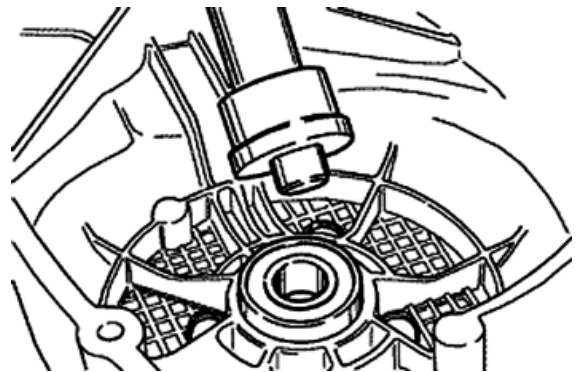

Baffle roller

Removal

Belt support roller (200 cm³ models only)

- Check that the roller does not show signs of wear and that it turns freely.
- Remove the special fixing screw and the roller together with the bearing.

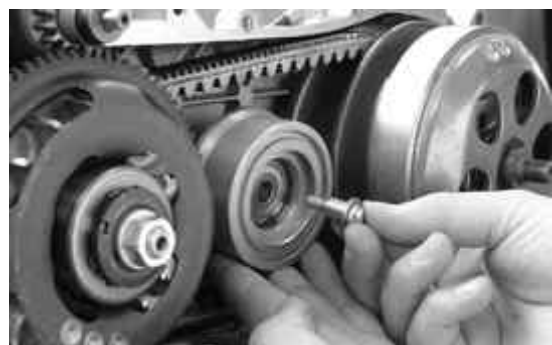

Refitting

- Heat the roller and insert the bearing using the specific punch:

Specific tools:

Specific tooling

020455Y 10-mm guide



- Refit the roller with the special screw.
- Tighten to the specified torque.
- Refit the intake throat with the O-ring, the sump sealing gasket and a the fan housing.

Locking torques (N*m)

Anti-flapping roller 12 - 16



Plastic roller

- Check that the roller does not show signs of wear and that it turns freely.
- Remove the special clamping screws as indicated in the photograph



- Check the outer diameter of the roller does not have defects that could jeopardise belt functioning
- For refitting, place the roller with the belt containment edge on the engine crankcase side
- Tighten the wrench to the prescribed torque.

Locking torques (N*m)

Anti-flapping roller 12 - 16



Removing the driven pulley

- Remove the spacer, the clutch bell and the whole driven pulley unit.

N.B.

THE UNIT CAN ALSO BE REMOVED WITH THE DRIVING PULLEY MOUNTED.

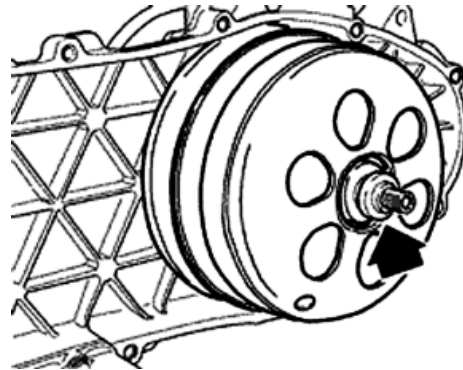

Inspecting the clutch drum

- Check that the clutch bell is not worn or damaged.
- Measure the clutch bell inside diameter.

Characteristic

Max. value clutch bell

Max. value: \varnothing 134.5 mm

Clutch bell standard value

Standard value: \varnothing 134 - 134.2 mm

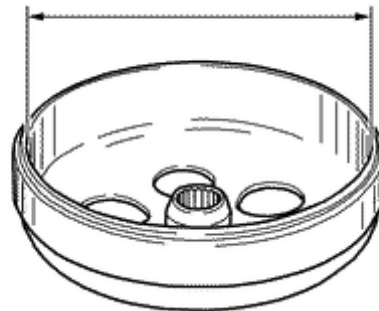

Checking the bell working surface eccentricity

- Install the bell on a driven pulley shaft using 2 bearings (inner diameter 15 and 17 mm).
- Lock with the original spacer and nut.
- Place the bell/shaft assembly on the support to check the crankshaft alignment.



- Using a feeler pin gauge and the magnetic base, measure the bell eccentricity.
- Repeat the measurement in 3 positions (Central, internal, external).
- If faults are found, replace the bell.



Specific tooling

020074Y Support base for checking crankshaft alignment

020335Y Magnetic support for dial gauge

Characteristic

clutch bell inspection: Limit eccentricity.

Admissible limit eccentricity: 0.15 mm

Removing the clutch

Fit the driven pulley spring compressor specific tool with medium length pins screwed in position «C» on the tool internal side.

- Introduce the adapter ring No. 11 with the chamfering facing the inside of the tool.
- Fit the driven pulley unit on the tool with the insertion of the 3 pins in the ventilation holes in the mass holder support.
- Make sure that the clutch is perfectly inserted into the adapter ring before proceeding to loosen/tighten the clutch nut.
- Use the special 46x55 wrench component No. 9 to remove the nut fixing the clutch in place.
- Dismantle the driven pulley components (Clutch and spring with its plastic holder)

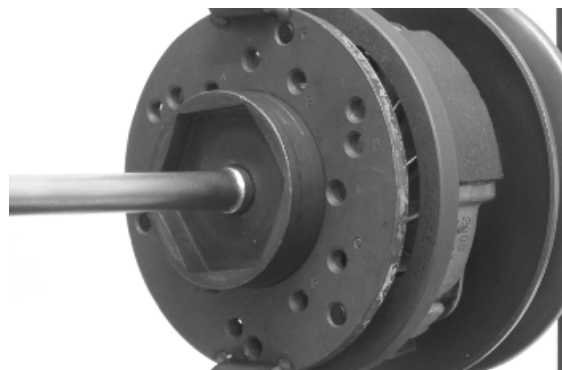

CAUTION

THE TOOL MUST BE FIRMLY FIXED IN THE CLAMP AND THE CENTRAL SCREW MUST BE BROUGHT INTO CONTACT WITH THE TOOL. EXCESSIVE TORQUE CAN CAUSE THE SPECIFIC TOOL TO BUCKLE.

Specific tooling

020444Y011 adapter ring

020444Y009 46x55 Wrench

020444Y Tool for fitting/ removing the driven pulley clutch

Inspecting the clutch

- Check the thickness of the clutch mass friction material.
- The masses must not show traces of lubricants; otherwise, check the driven pulley unit seals.

N.B.

UPON RUNNING-IN, THE MASSES MUST EXHIBIT A CENTRAL CONTACT SURFACE AND MUST NOT BE DIFFERENT FROM ONE ANOTHER.

VARIOUS CONDITIONS CAN CAUSE THE CLUTCH TO TEAR.

CAUTION

DO NOT OPEN THE MASSES USING TOOLS TO PREVENT A VARIATION IN THE RETURN SPRING LOAD.

Characteristic

Check minimum thickness

1 mm



Pin retaining collar

- Simultaneously turn and pull the collar manually to remove it.

N.B.

USE TWO SCREWDRIVERS IF YOU HAVE DIFFICULTY.

N.B.

BE CAREFUL NOT TO PUSH THE SCREW DRIVERS IN TOO FAR TO AVOID DAMAGE THAT COULD ENDANGER THE O-RING SEAL.



-
- Remove the four torque server pins and pull the pulley halves apart.



Removing the driven half-pulley bearing

- Check there are no signs of wear and/or noisiness; - Replace with a new one if there are.
- Remove the retaining ring using two flat blade screwdrivers.
- Support the pulley bushing adequately from the threaded side using a wooden surface.
- Using a hammer and pin, knock the ball bearing out as shown in the figure.

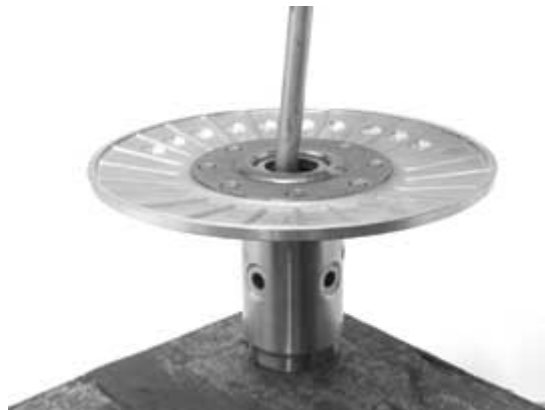

- Support the pulley properly using the bell as shown in the figure.

Specific tooling

001467Y035 Belle for OD 47-mm bearings



- Remove the roller bearing using the modular punch.

Specific tooling

020376Y Adaptor handle

020456Y Ø 24 mm adaptor

020363Y 20 mm guide

Inspecting the driven fixed half-pulley

- Measure the pulley bushing outside diameter.
- Check that the contact surface with the belt is free from abnormal wear.
- Check the riveting.
- Check the belt contact surface planarity.

Characteristic

Half-pulley minimum diameter

Minimum admissible diameter \varnothing 40.96 mm

Half-pulley standard diameter

Standard diameter: \varnothing 40.985 mm

Wear limit

0.3 mm



Inspecting the driven sliding half-pulley

- Remove the two internal grommets and the two O-rings.
- Measure the movable half-pulley bushing inside diameter.
- Check the contact surface with the belt to make sure there are no flaws.
- Check the riveted joints are functional.
- Check the evenness of the belt faying surface.

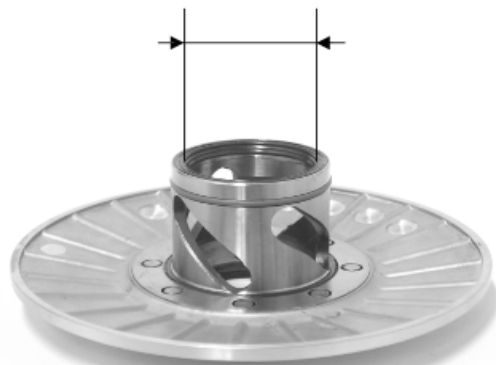

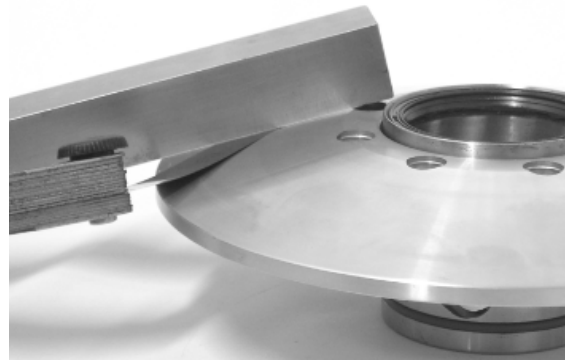

MOVABLE DRIVEN HALF-PULLEY DIMENSIONS

Specification	Desc./Quantity
Wear limit	0.3 mm
standard diameter	Diameter 41.000 - 41.035 mm
maximum allowable diameter	Ø 41.08 mm

Refitting the driven half-pulley bearing

- Support the pulley bushing adequately from the threaded side using a wooden surface.
- Fit a new roller sleeve as in the figure.
- For the fitting of the new ball bearing, follow the example in the figure using a modular punch.
- Fit the retention ring

WARNING

N.B.

FIT THE BALL BEARING WITH THE VISIBLE SHIELD

Specific tooling

020376Y Adaptor handle

020375Y Adaptor 28 x 30 mm

020424Y Driven pulley roller casing fitting punch



Refitting the driven pulley

- Insert the new oil guards and O-rings on the movable half-pulley.
- Lightly grease the O-rings «A» shown in the figure.
- Fit the half-pulley over the bushing using the specific tool.
- Check that the pins are not worn and proceed to refitting them in their slots.
- Refit the torque server closure collar.
- Using a curved-spout grease gun, lubricate the driven pulley unit with approximately 6 gr. of grease. Apply the grease through one of the holes in the bushing until it comes out through the hole on the opposite side. This operation is necessary to avoid the presence of grease beyond the O-rings.

N.B.

THE TORQUE SERVER CAN BE GREASED WHETHER WITH BEARINGS FITTED OR WHEN THEY ARE BEING REPLACED; UNDERTAKING THE OPERATION WHEN THE BEARINGS ARE BEING SERVICED MIGHT BE EASIER.

Specific tooling

020263Y Sheath for driven pulley fitting

Recommended products

AGIP GREASE SM 2 Grease for the tone wheel revolving ring

Soap-based lithium grease containing NLGI 2 Molybdenum disulphide; ISO-L-XBCHB2, DIN KF2K-20



Inspecting the clutch spring

- Measure the free length of the mobile driven half-pulley spring.

Characteristic
Standard length

123 mm

acceptable limit after use:

118 mm

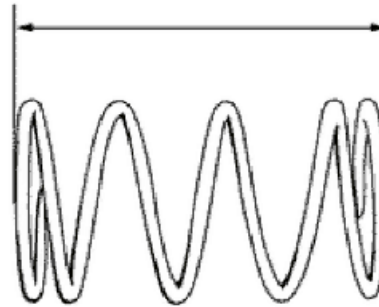

Refitting the clutch

- Support the driven pulley spring compressor appropriate tool with the control screw in vertical axis.
- Arrange the tool with the medium length pins screwed in position "C" on the inside.
- Introduce the adapter ring 11 with the chamfering facing upwards.
- Insert the clutch on the adapter ring.
- Lubricate the end of the spring that abuts against the servo-system closing collar.
- Insert the spring with its plastic holder in contact with the clutch.
- Insert the driving belt into the pulley unit according to their direction of rotation.
- Insert the pulley unit with the belt into the tool.
- Slightly preload the spring.
- Make sure that the clutch is perfectly inserted into the adapter ring before proceeding to tighten the clutch nut.
- Place the tool in the clamp with the control screw on the horizontal axis.
- Fully preload the spring.
- Apply the clutch fixing nut and tighten it to the prescribed torque using the special 46x55 wrench.
- Loosen the tool clamp and insert the belt according to its direction of rotation.

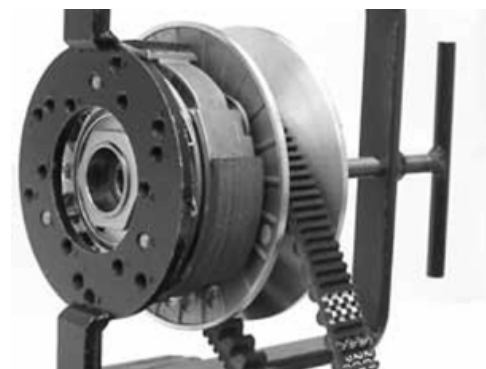

- Lock the driven pulley again using the specific tool.
- Preload the clutch return spring with a traction/ rotation combined action and place the belt in the smaller diameter rolling position.
- Remove the driven pulley /belt unit from the tool.

N.B.

DURING THE SPRING PRELOADING PHASE, BE CAREFUL NOT TO DAMAGE THE PLASTIC SPRING STOP AND THE BUSHING THREADING.

N.B.

FOR DESIGN REASONS, THE NUT IS SLIGHTLY ASYMMETRIC; THE FLATTEST SURFACE SHOULD BE MOUNTED IN CONTACT WITH THE CLUTCH.

Specific tooling

020444Y Tool for fitting/ removing the driven pulley clutch

020444Y011 adapter ring

020444Y009 46x55 Wrench

Locking torques (N*m)

Nut locking clutch unit on pulley 55 ÷ 60 Nm

Refitting the driven pulley

- Reassemble the clutch bell and spacer.

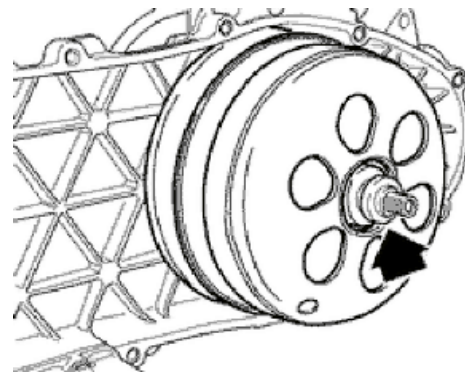

Drive-belt

- Ensure the drive-belt is not damaged.
- Check the drive-belt width.

Characteristic

Driving belt - standard width

21,3 ± 0,2 mm

Driving belt - minimum width

19,5 mm

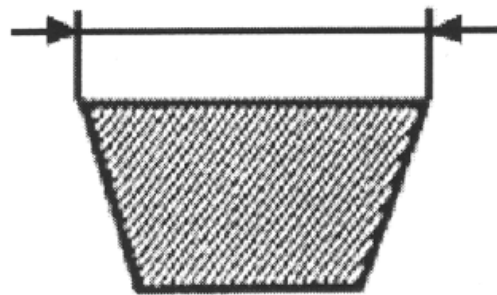
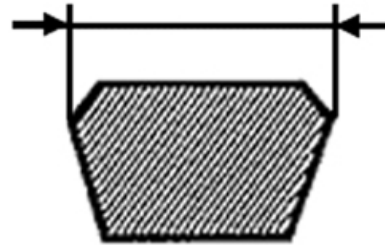

During the wear checks foreseen in the scheduled maintenance services at 6,000 km; 18,000 km; etc., check that the rim bottom of the toothing does not show signs of incisions or cracking (see figure): The rim bottom of the tooth must not have incisions or cracking; if it does, change the belt.

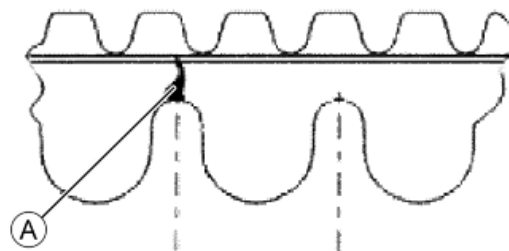

Removing the driving pulley

- Turn the crankshaft until the ropes of the pulley are on a horizontal axis



- Insert the adaptor sleeve of the appropriate tool in the hole shown in the photograph

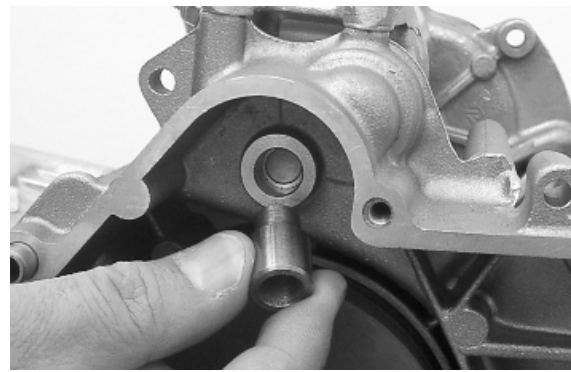

- Insert the tool in the hollows and apply the retention ring
- Bring in the ring's clamping screws while keeping the tool to support the pulley

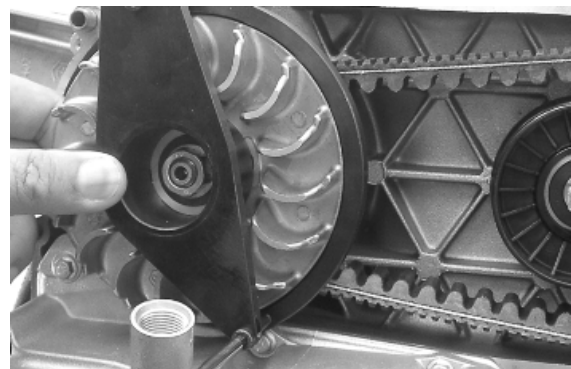

Specific tooling

020626Y Driving pulley lock wrench

- Remove the fixing nut and the washer
- Remove the stationary drive pulley half.

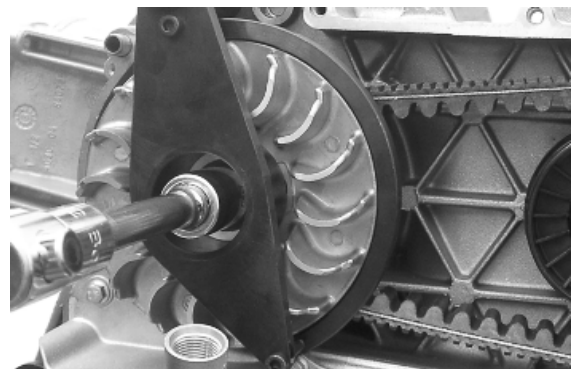

Inspecting the rollers case

- Ensure the internal bearing, shown in the figure, is not abnormally worn and measure the internal diameter.
- Measure the external diameter of the pulley sliding bushing, shown in the figure.
- Ensure rollers are not damaged or worn.
- Ensure the roller plate shoes are not damaged.
- Check the wear of the roller housings and of the belt contact surfaces on both half-pulleys.

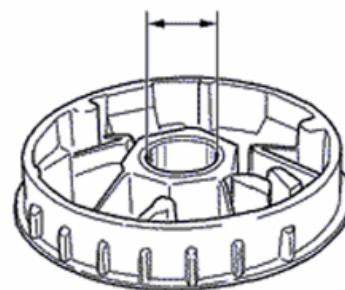

- Ensure the fixed driving pulley exhibits no abnormal wear on the grooved profile and on the belt contact surface.
- Ensure the O-ring is not deformed.

CAUTION

DO NOT LUBRICATE OR CLEAN SINTERED BUSHINGS

Characteristic

Movable driving half-pulley bushing: Standard Diameter

26.000 - 26.021 mm

Movable driving half-pulley bushing: Maximum allowable diameter

Ø 26.12 mm

Sliding bushing: Standard Diameter

Ø 25.959 ÷ 25.98 mm

Sliding bushing: Minimum admissible diameter

Ø 25.95 mm

Roller: Standard Diameter

Diameter 20.5 - 20.7 mm

Roller: Minimum diameter permitted

Ø 20 mm



Refitting the driving pulley

- Fit the steel shim in contact with the bushing and the stationary drive pulley.
- Install the appropriate tool as described in the removal phase.
- Tighten the nut with washer to the prescribed torque.

Specific tooling

020626Y Driving pulley lock wrench

Locking torques (N*m)

Drive pulley nut 75 ÷ 83

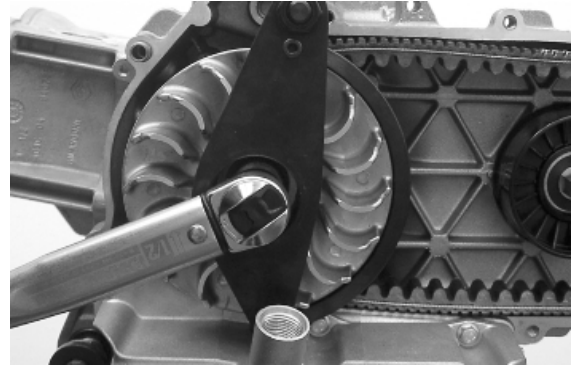

-
- Preassemble the movable half-pulley with the roller contrast plate by putting the rollers in their housings with the larger support surface touching the pulley according to the direction of rotation.
 - Check that the roller contact plate does not have flaws and is not damaged on the grooved edge.
 - Mount the complete bushing unit on the driving shaft.
 - Fit the driven pulley/Clutch/belt unit on the engine.

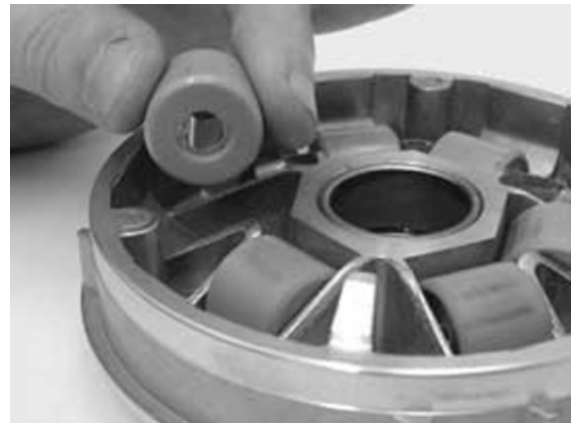

Refitting the transmission cover

- Check the presence of the 2 centring dowels and the correct installation of the sealing gasket for the oil sump on the transmission cover.
- Replace the cover tightening the 10 screws at the specified torque.
- Refit the oil loading cap/bar.
- refit the steel washer and the driven pulley nut.
- Tighten the nut to the prescribed torque using the lock wrench and the torque wrench tools.
- Replace the plastic cover.

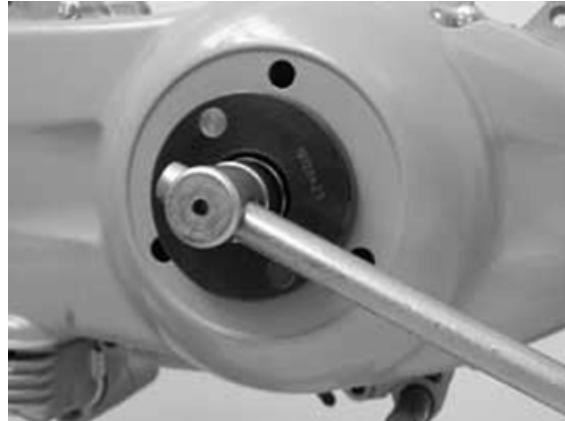

Specific tooling

020423Y driven pulley lock wrench

Locking torques (N*m)

Transmission cover screws 11 ÷ 13 Driven pulley shaft nut 54 ÷ 60

End gear

Removing the hub cover

- Empty the rear hub through the oil drainage plug.
- Remove the 7 flanged screws indicated in the figure.
- Remove the hub cover and its gasket.

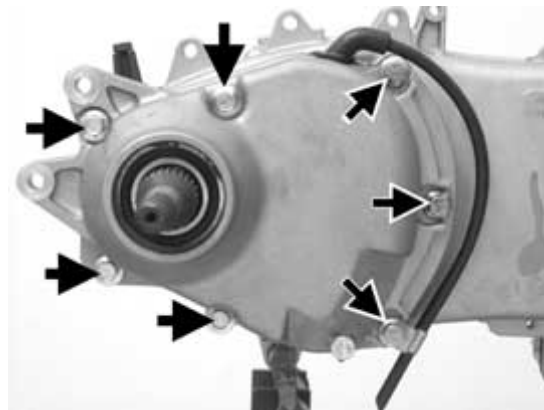

Removing the wheel axle

- Remove the wheel axle complete with gear.
- Remove the intermediate gear.

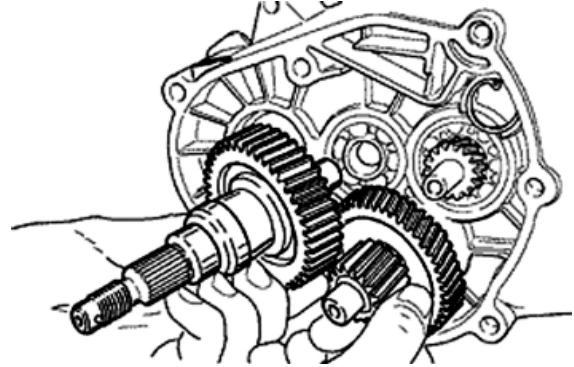

Removing the hub bearings

- Check the state of the bearings being examined (wear, clearance and noisiness). If faults are detected, do the following.
- Use the specific bearing extractor to remove the three 15 mm bearings (2 in the crankcase and 1 in the hub cover).

Specific tooling

001467Y013 Pliers to extract \varnothing 15-mm bearings

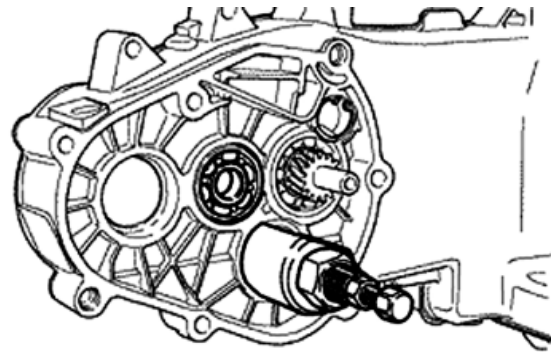

Removing the wheel axle bearings

- Take out the clip on the outside of the gearbox cover.
- Support the hub cover and expel the bearing. By means of the appropriate tools, remove the oil guard as in the figure.

Specific tooling

020376Y Adaptor handle

020477Y Adaptor 37 mm

020483Y 30 mm guide

020359Y 42x47-mm adaptor

020489Y Hub cover support stud bolt set

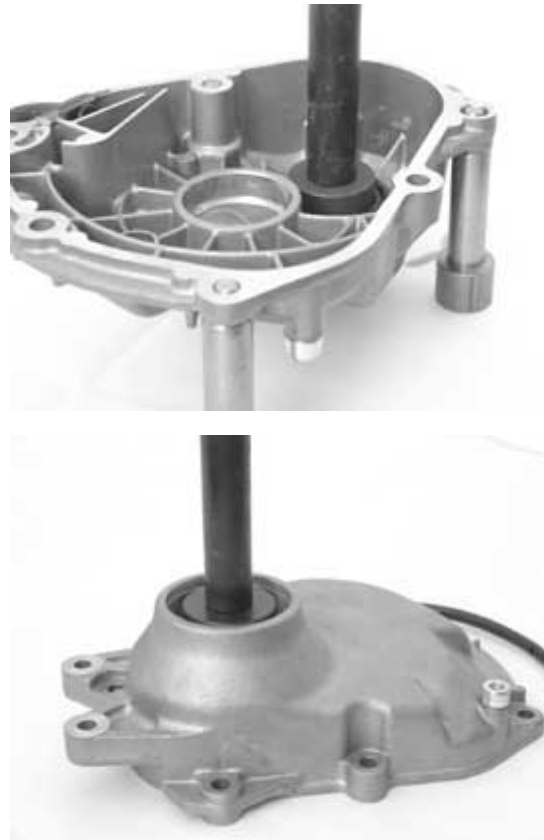

Removing the driven pulley shaft bearing

- As you need to remove the driven pulley shaft, its bearing and oil guard, remove the transmission cover as described above.
- Extract the driven pulley shaft from its bearing.
- Remove the oil guard using a screwdriver, working from inside the bearing and being careful not to damage the housing, make it come out of the belt transmission side.
- Remove the Seeger ring shown in the figure. Remove the driven pulley shaft bearing using the modular punch.

Specific tooling

020376Y Adaptor handle

020375Y Adaptor 28 x 30 mm

020363Y 20 mm guide

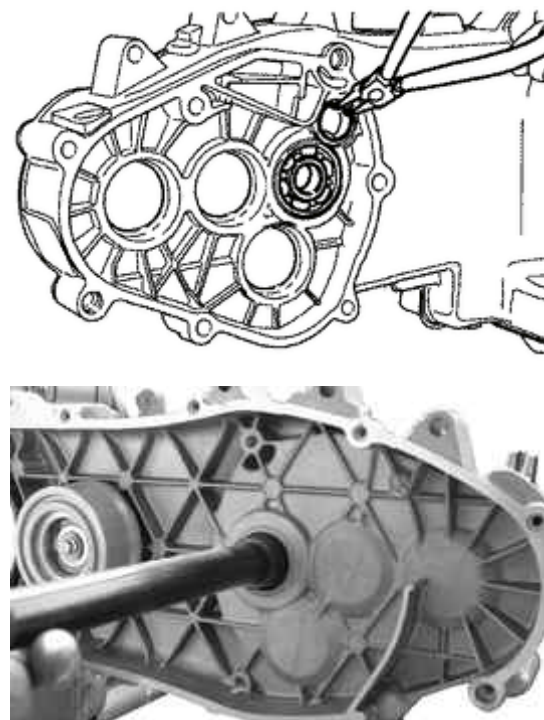

Inspecting the hub shaft

- Check the three shafts for wear or distortion of the toothed surfaces, the bearing housings, and the oil seal housings.
- In case of anomalies, replace the damaged components.



Inspecting the hub cover

- Check that the fitting surface is not dented or distorted.
- Check the bearing bearings.
- In case of anomalies, replace the damaged components.

Refitting the wheel axle bearing

- Support the hub cover on a wooden surface.
- Heat the crankcase cover with the specific heat gun.
- Fit the wheel shaft bearing with a modular punch as shown in the figure.
- Fit the Seeger ring.
- Fit the oil guard with seal lip towards the inside of the hub and place it flush with the internal surface by means of the appropriate tool used from the 52 mm side.

The 52 mm side of the adaptor must be turned towards the bearing.

Specific tooling

020376Y Adaptor handle

020360Y Adaptor 52 x 55 mm

020483Y 30 mm guide





Refitting the hub cover bearings

In order to fitting of the hub box bearings, the engine crankcase and the cover must be heated with the special heat gun.

- The three 15 mm bearings must be fitted using the appropriate tools.
- The 42-mm side of the adaptor must be turned towards the bearing.

Specific tooling

020150Y Air heater support

020151Y Air heater

020376Y Adaptor handle

020359Y 42x47-mm adaptor

020412Y 15 mm guide

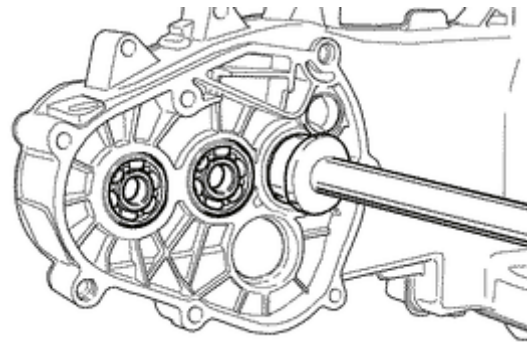

N.B.

TO FIT THE BEARING ON THE COVER, SUPPORT THE COVER WITH THE STUD BOLT SET.

-
- Refit the driven pulley shaft bearing with a modular punch as shown in the figure.

N.B.

IF THE BEARING HAS AN ASYMMETRICAL BALL RETAINER, PLACE IT SO THAT THE BALLS ARE VISIBLE FROM THE HUB INNER SIDE.

Specific tooling

020376Y Adaptor handle

020359Y 42x47-mm adaptor

020363Y 20 mm guide

N.B.

WHEN FITTING THE BEARINGS ON THE ENGINE CRANKCASE, SUPPORT THE CRANKCASE PREFERABLY ON A SURFACE TO ALLOW THE BEARINGS TO BE DRIVEN VERTICALLY.

- Refit the Seeger ring with the opening facing the bearing and fit a new oil guard flush with the crankcase from the pulley side.



Refitting the hub bearings

- Install the three shafts in the engine crankcase as shown in the figure.

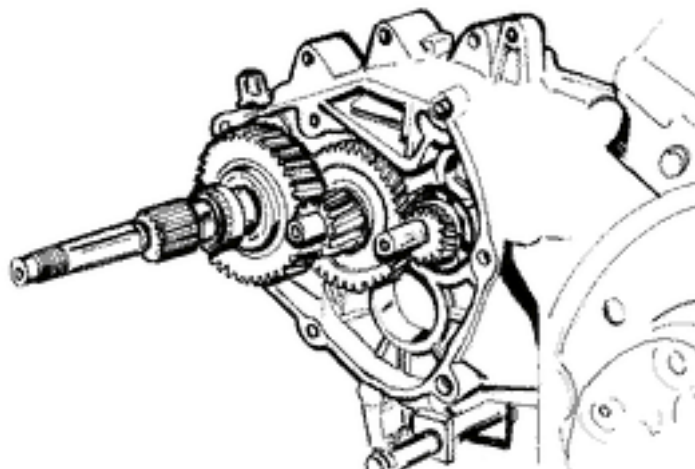

Refitting the ub cover

- Fit a new gasket together with the centring dowels.
- Seal the gasket of the breather pipe using black silicone sealant.
- Fit the gearbox cover, making sure the breather pipe is in the correct position.
- Place the 3 shortest screws, identifiable by their different colour, as shown in the figure.
- Fasten the breather pipe support bracket with the lower short screw.
- Assemble the remaining 4 screws and tighten the 7 screws to the prescribed torque.

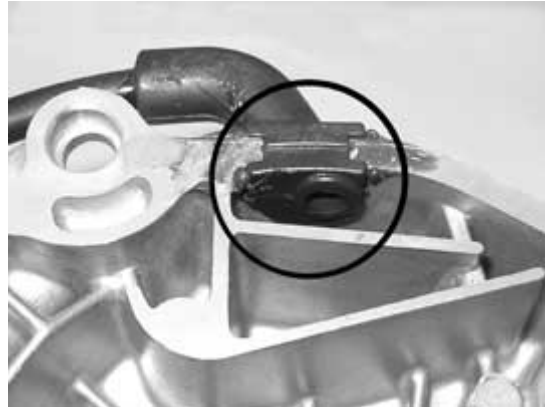

Locking torques (N*m)

Rear hub cover screws 24 ÷ 27

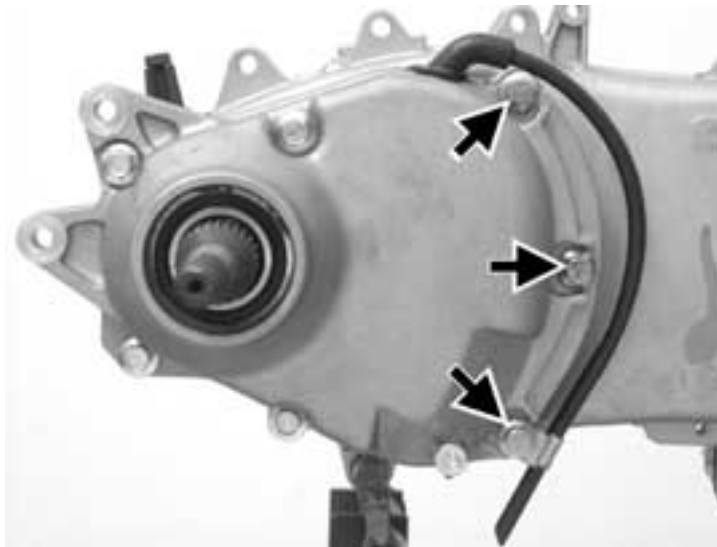

Flywheel cover

Removing the hub cover

- Remove the clip fixing the hose to the cylinder.
- Remove the ten fixings
- Remove the flywheel cover.

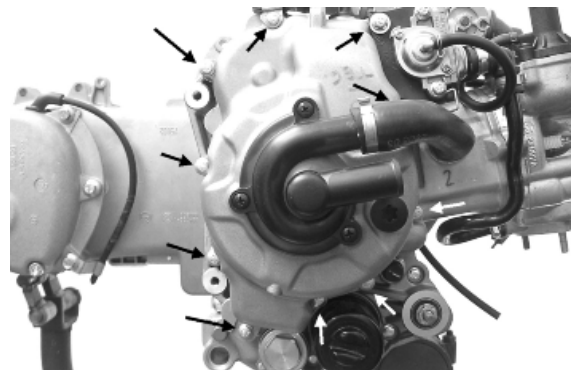
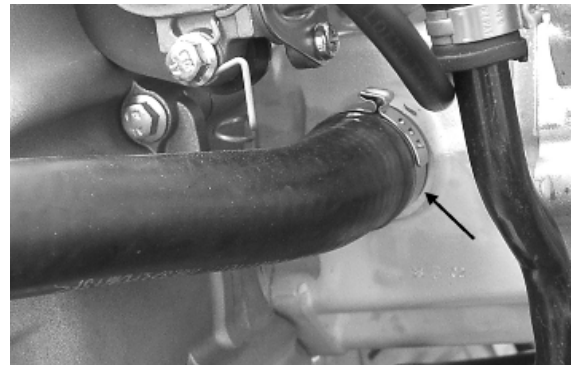

Removing the stator

- Remove the two pickup screws and the screw holding the wiring support and the three stator clamping screws shown in the figure.
- Remove the stator and its wiring.



Refitting the stator

- Refit the stator and flywheel carrying out the removal procedure in reverse, tightening the retainers to the specified torque.

Locking torques (N*m)

Stator assembly screws (°) 3 ÷ 4



Refitting the flywheel cover

- Position the spline clip on the crankshaft and orient the end as shown in the figure.

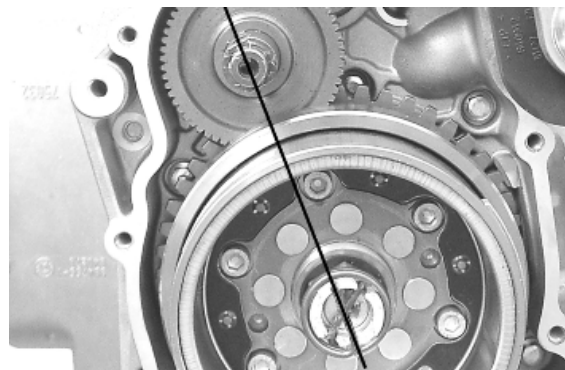

- Orient the water pump shaft with reference to the transmission gear seat as shown in the photo.

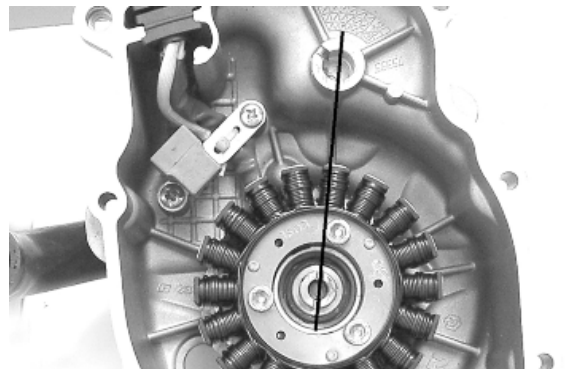

- Refit the cover over the engine and tighten the screws to the prescribed torque.
- Carry out the steps in the reverse order from the dismantling procedure.

CAUTION

TAKE CARE TO CORRECTLY POSITION THE FLYWHEEL CONNECTOR. MAKE SURE THE CENTRING DOWELS ARE PRESENT.

Locking torques (N*m)

Flywheel cover screws 11 - 13

Flywheel and starting

Removing the starter motor

- Remove the two screws indicated in the figure.
- Take the starter motor out of its seat

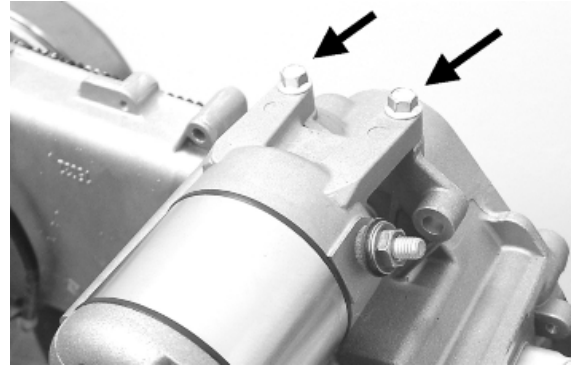

Removing the flywheel magneto

- Lock the rotation of the Flywheel with the calliper spanner tool.
- Remove the nut.
- Take out the flywheel.

CAUTION

THE USE OF A CALLIPER SPANNER OTHER THAN THE ONE SUPPLIED COULD DAMAGE THE STATOR COILS

Specific tooling

020565Y Flywheel lock calliper spanner

008564Y Flywheel extractor

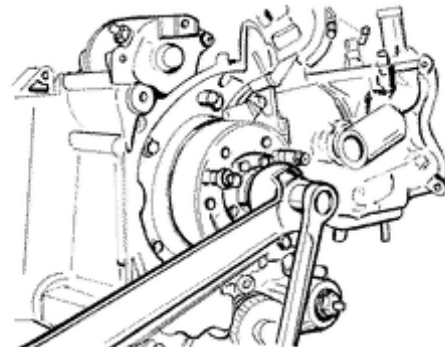
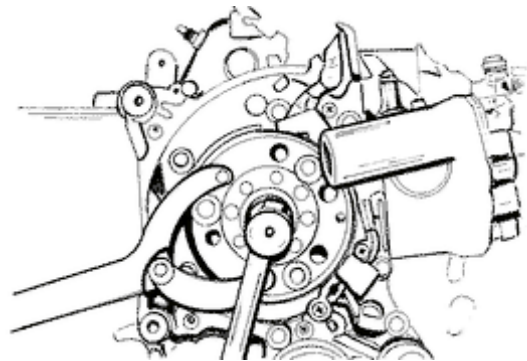

-
- Remove the water pump shaft and crankshaft spline clip

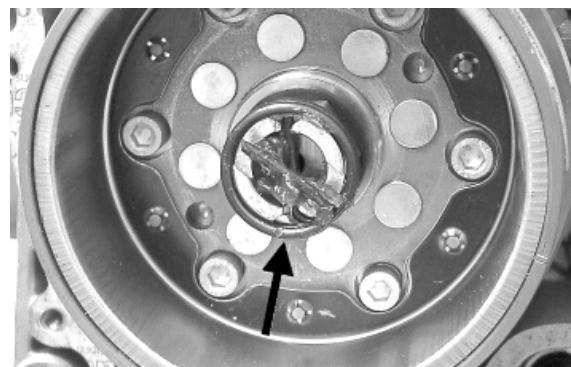

- Line up the two holes in the flywheel as shown in the photo



- Screw in the guide bushing that is part of the special flywheel stop tool on the flywheel as shown in the photo.



- Insert the special flywheel stop tool on the flywheel as shown in the photo

Specific tooling

020627Y Flywheel lock wrench



- Remove the flywheel nut with its washer
- Do up the flywheel nut by three or four threads so that the flywheel does not fall accidentally on extraction
- Screw the extractor onto the flywheel and extract it as shown in the photograph

Specific tooling

020467Y Flywheel extractor



Inspecting the flywheel components

- Check the integrity of the internal plastic parts of the flywheel and the Pick-Up control plate.

Refitting the free wheel

- Make sure the freewheel faying surfaces are in good condition.
- Thoroughly clean the free wheel to remove LOCTITE residue.
- Degrease the threading of the holes in the free wheel and the clamping screws.
- Apply the recommended product to the end of the screws.

Recommended products

Loctite 243 Medium-strength threadlock

Loctite 243 medium-strength threadlock

- Fit the freewheel on the magneto flywheel making sure that the ground side is in contact with the flywheel itself, i.e. with wheel Seeger ring visible.
- Lock the six clamping screws in criss-cross fashion to the prescribed torque.



Locking torques (N*m)

Screw fixing freewheel to flywheel 13 ÷ 15

- Oil the free wheel "rollers".



Refitting the flywheel magneto

- Fit the flywheel being careful to insert the key properly.
- Lock the flywheel nut to the prescribed torque
- Check that the Pick-Up air gap is between 0.34 ÷ 0.76 mm.

The air gap cannot be modified when assembling the Pick-Up.

Different values result from deformations visible on the Pick-Up support.

N.B.



**A VARIATION IN THE AIR GAP DISTANCE
MODIFIES THE IGNITION SYSTEM IDLE
SPEED**

Specific tooling

020565Y Flywheel lock calliper spanner

Locking torques (N*m)

Flywheel nut 54 ÷ 60

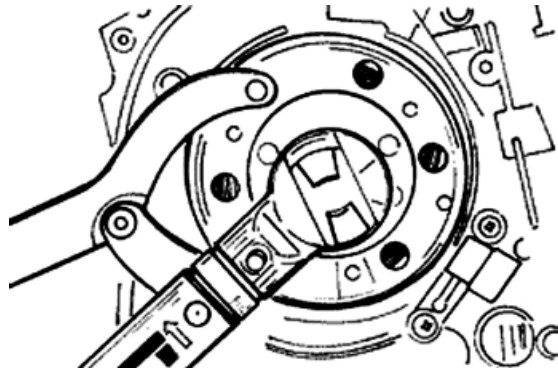

- Remove the freewheel retaining plate indicated in the photograph
- Remove the transmission gear and the freewheel

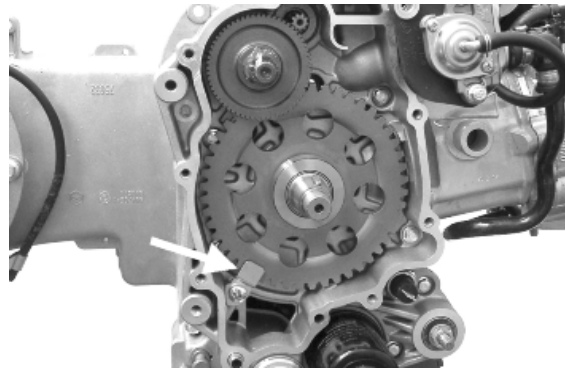

- Insert the free wheel on the flywheel as shown in the photo
- Then refit the flywheel with free wheel and transmission gear



- Using the special flywheel stop tool, tighten up the flywheel fixing nut to the prescribed torque
- Refit the retention plate

Specific tooling

020627Y Flywheel lock wrench

Locking torques (N*m)

Flywheel nut 94 ÷ 102



Refitting the starter motor

- Fit a new O-ring on the starter motor and lubricate it.
- Fit the starter on the crankcase, locking the two screws to the prescribed torque.

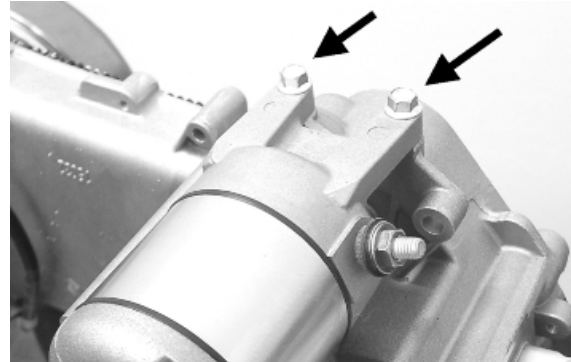
Locking torques (N*m)**Starter motor screws $11 \div 13$** 

Cylinder assy. and timing system

Removing the intake manifold

- Remove the flywheel cover as described in the Flywheel cover chapter.
- Loosen the 3 screws and remove the intake manifold.

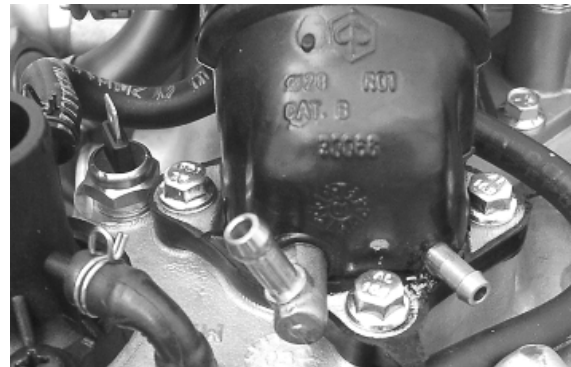

Removing the rocker-arms cover

- Remove the 5 screws indicated in the figure

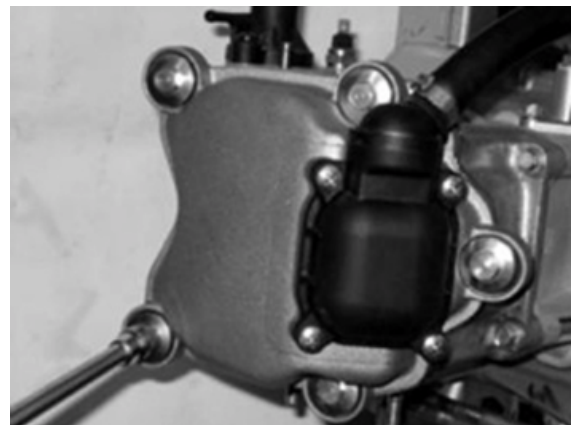

Removing the timing system drive

- First remove the parts listed below: transmission cover, drive pulley with belt, oil sump with spring and by-pass piston, oil pump pulley cover, O-ring on the crankshaft and the sprocket wheel separation washer.

- Remove the tappet cover.

- Remove the central screw fastener and the automatic valve-lifter retaining cover, as shown in the figure.



- Remove the return spring of the automatic valve lifter unit and the automatic valve lifter unit and its end of stroke washer.

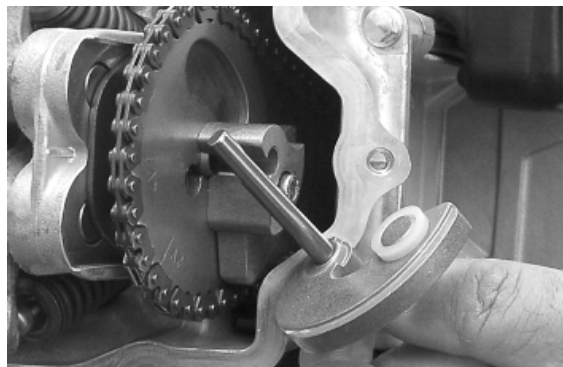

- Loosen the central screw on the tensioner first.

- Remove the two fixings shown in the figure.

- Remove the tensioner with its gasket.

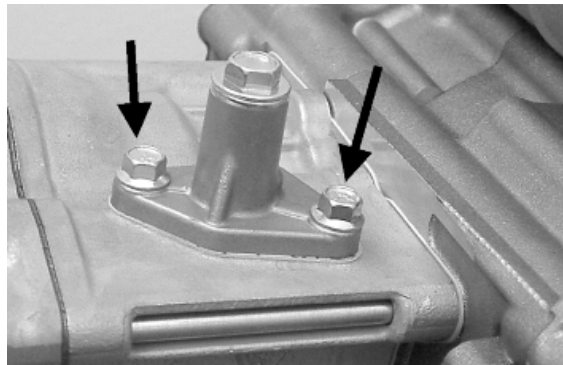

- Remove the internal hex screw and the counterweight shown in the figure.

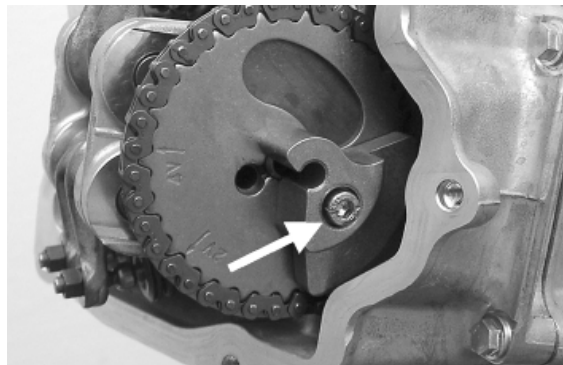

- Remove the camshaft control pulley with its washer.

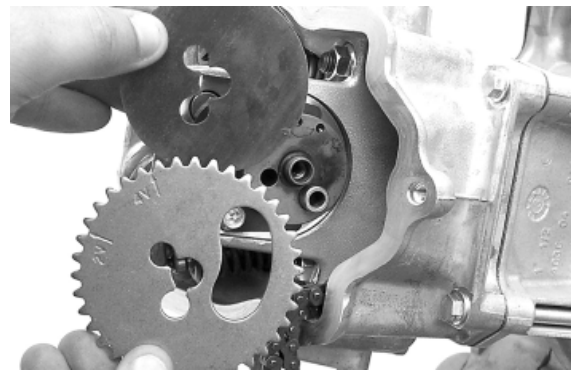

- Remove the command sprocket wheel and the timing chain.

- Remove the screws indicated in the figure, the spacer bar and the tensioner slider.

The chain tensioning pad must be removed from the transmission side. As regards the lower chain guide pad, it may only be removed after the head has been removed.

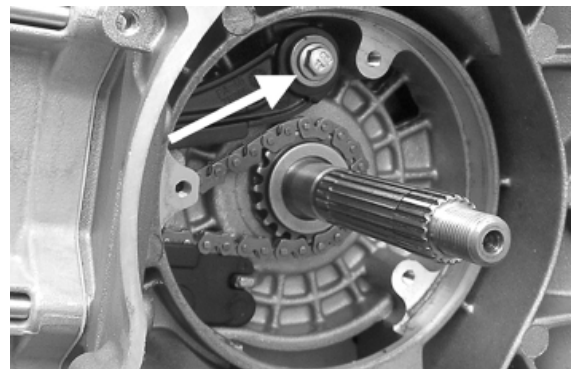

N.B.

IT IS ADVISABLE TO MARK THE CHAIN IN ORDER TO ENSURE THAT THE INITIAL DIRECTION OF ROTATION IS MAINTAINED.

Removing the cam shaft

- Remove the two screws and the cam shaft retainer shown in the diagram.
- Remove the cam shaft.
- Remove the pins and the rocker arms from the flywheel side holes.

N.B.

IN CASE OF NEED, THE HEAD MAY BE REMOVED WITH THE CAMSHAFT, PINS, ROCKING LEVERS AND FIXING BRACKET. THE HEAD CAN ALSO BE REMOVED WITHOUT REMOVING THE CHAIN AND THE DRIVING SHAFT CHAIN TIGHTENER.

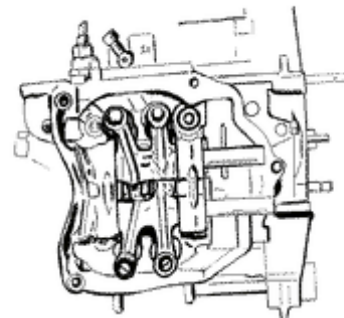

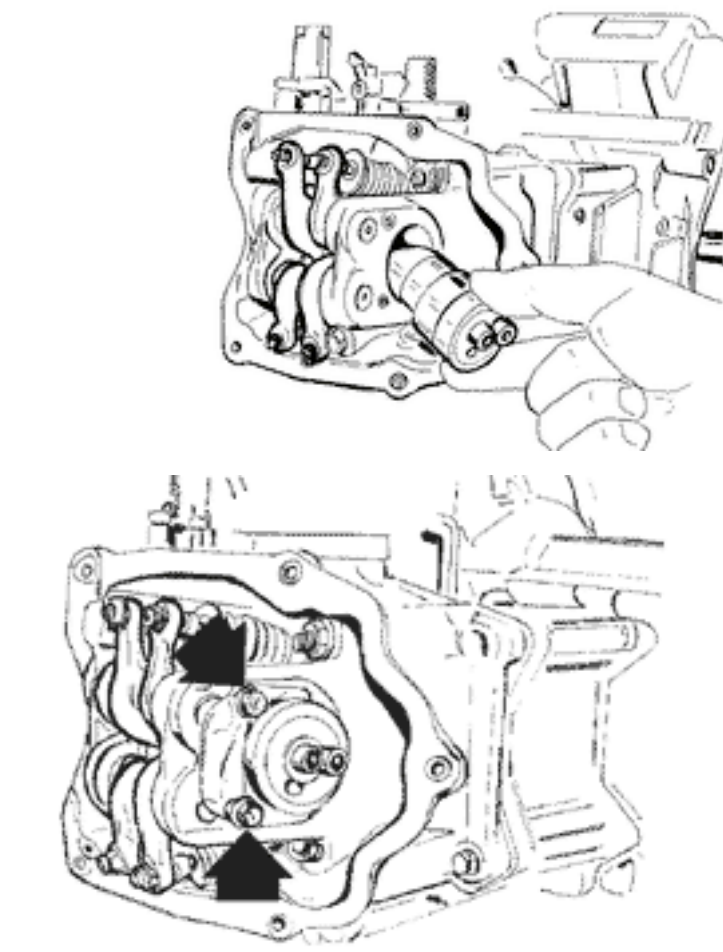

Removing the cylinder head

- Remove the spark plug.
- Remove the 2 side fixings shown in the figure.
- Loosen the 4 head-cylinder fastening nuts in two or three stages and in criss-cross fashion.
- Remove the head, the two centring dowels and the gasket.

N.B.

IN CASE OF NEED, THE HEAD MAY BE REMOVED WITH THE CAMSHAFT, PINS, ROCKING LEVERS AND FIXING BRACKET. THE HEAD CAN ALSO BE REMOVED WITHOUT REMOVING THE CHAIN AND THE DRIVING SHAFT CHAIN TIGHTENER.

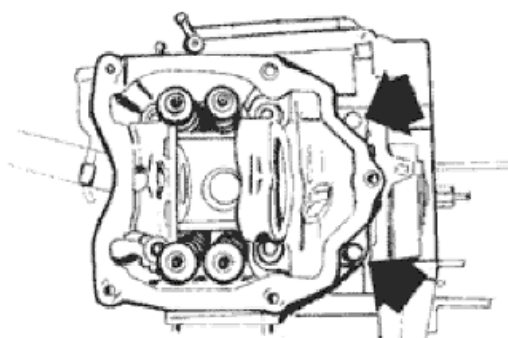

Removing the valves

- Using the appropriate tool fitted with an adaptor, remove the cotters, caps, springs and valves.
- Remove the oil guards with the appropriate tool.
- Remove the lower spring supports.

CAUTION

REPLACE THE VALVES IN SUCH A WAY AS TO RECOGNISE THEIR ORIGINAL POSITION ON THE HEAD.

Specific tooling

020382Y011 adapter for valve removal tool

020382Y Valve cotters equipped with part **012** removal tool

020306Y Punch for assembling valve seal rings



Removing the cylinder - piston assy.

- Remove the chain guide pad.
- Pull out the cylinder.
- Remove the cylinder base gasket.
- Remove the two stop rings, the wrist pin and the piston.
- Remove the piston seals.

CAUTION

TO AVOID DAMAGING THE PISTON, SUPPORT IT WHILE REMOVING THE CYLINDER.

N.B.

BE CAREFUL NOT TO DAMAGE THE SEALING RINGS DURING REMOVAL.

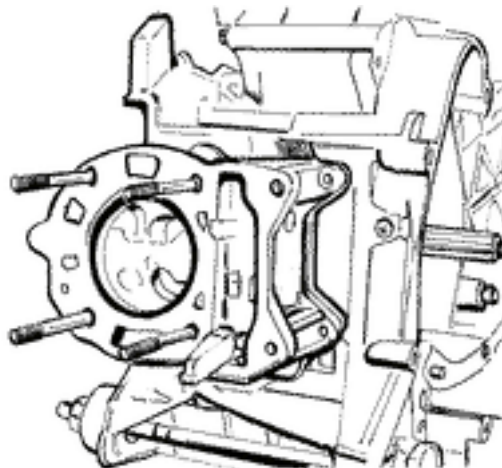

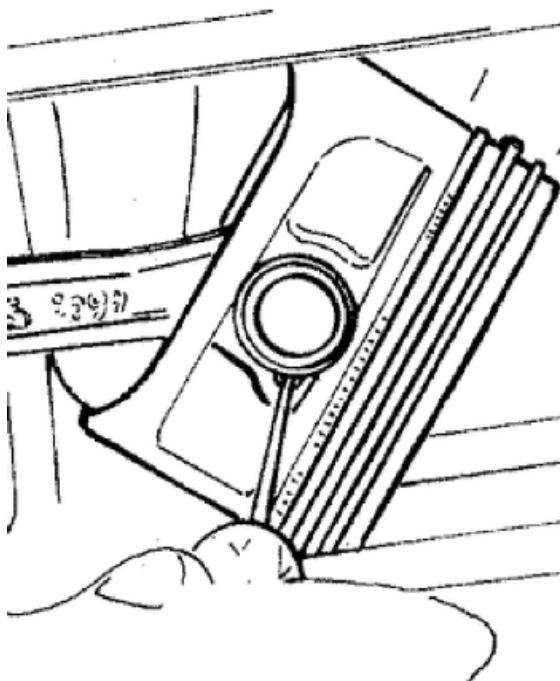
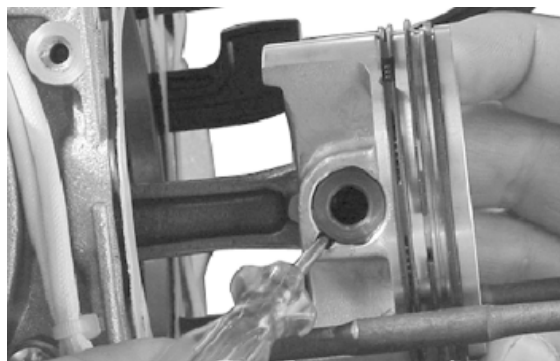

Inspecting the small end

- Measure the internal diameter of the rod small end using an internal micrometer.

N.B.

REPLACE THE CRANKSHAFT IF THE DIAMETER OF THE ROD SMALL END EXCEEDS THE STANDARD DIAMETER OR IT SHOWS SIGNS OF WEAR OR OVERHEATING.

Characteristic

Rod small end check-up: Maximum diameter

15.030 mm

Rod small end check-up: Standard diameter

15 +0.015+0.025 mm

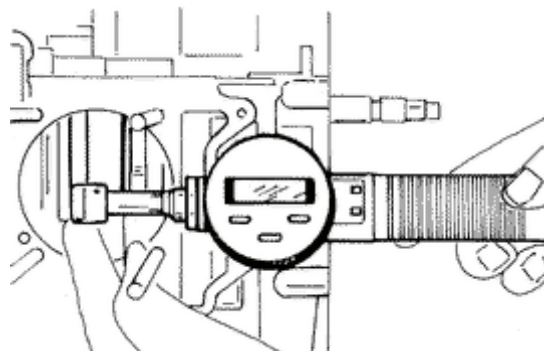

Inspecting the wrist pin

- Measure the outer diameter of the gudgeon pin.
- Calculate the coupling clearance between pin and connecting rod end.

Characteristic

Pin diameter: Standard clearance

0.015 ÷ 0.029 mm

Pin diameter Standard diameter

14.996 - 15.000 mm

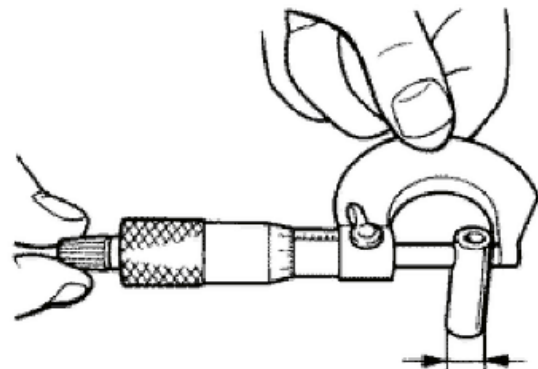

Inspecting the piston

- Measure the diameter of the wrist pin seat on the piston.
- Calculate the piston pin coupling clearance.
- Measure the outside diameter of the piston, perpendicular to the gudgeon pin axis.
- Take the measurement at 5 mm from the base in the position shown in the figure.
- Carefully clean the seal housings.
- Measure the coupling clearance between the seal rings and the grooves using suitable sensors, as shown in the diagram.
- If the clearance is greater than that indicated in the table, replace the piston.

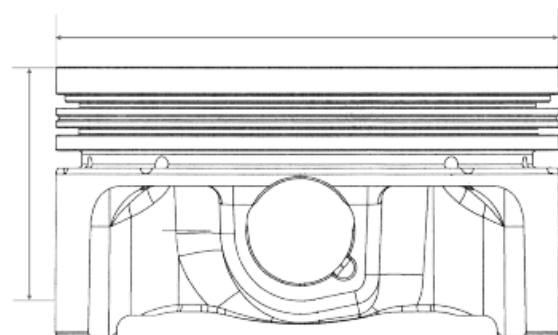

N.B.

MEASURE THE CLEARANCE BY INSERTING THE BLADE OF THE FEELER GAUGE FROM THE SECOND SEAL SIDE.

N.B.

THE PIN HOUSINGS HAVE 2 LUBRICATION CHANNELS. FOR THIS REASON MEASUREMENT OF THE DIAMETER MUST BE CARRIED OUT ACCORDING TO THE AXIS OF THE PISTON.

Characteristic

Wrist pin seat on the piston: Standard diameter

15.001 ÷ 15.006 mm

Diameter of the wrist pin seat on the piston: Standard clearance

0.001 ÷ 0.010 mm

piston diameter

71.953 - 71.981 mm

Fitting clearance

Top piston ring - standard coupling clearance 0.015 - 0.06 mm **Top piston ring - maximum clearance allowed after use** 0.07 mm **Middle piston ring - standard coupling clearance** 0.015 - 0.06 mm **Middle piston ring - maximum clearance allowed after use** 0.07 mm **oil scraper ring - standard coupling clearance** 0.015 - 0.06 mm **oil scraper ring - maximum clearance allowed after use** 0.07 mm

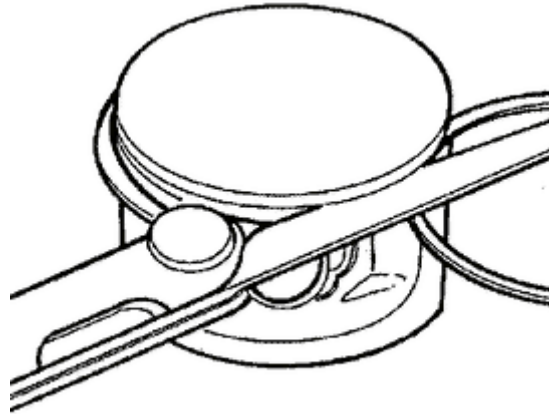

Inspecting the cylinder

- Using a bore gauge, measure the internal diameter of the cylinder following the directions given in the figure and at three different heights.
- Check that the plane of coupling with the head does not show wear or deformations.
- The pistons and cylinders are classified with categories depending on the diameters. The coupling is carried out matched (A-A, B-B, C-C, D-D).

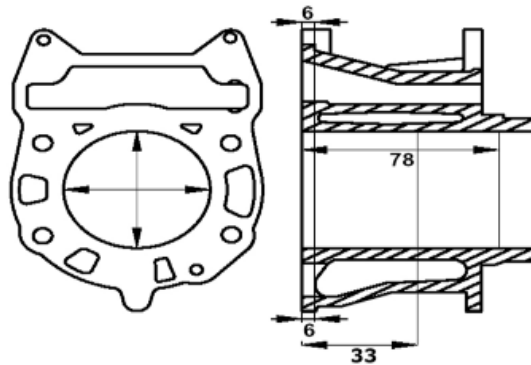

Characteristic

cylinder: standard diameter

71.990 - 72.018 mm (at 33 mm)

Maximum allowable run-out:

0.05 mm

Removing the piston

- Install piston and wrist pin onto the connecting rod, aligning the piston arrow the arrow facing towards the exhaust.
- Fit the wrist pin stop ring onto the appropriate tool
- With opening in the position indicated on the tool
S = left
D = right
- Place the wrist pin stop ring into position using a punch



- Fit the wrist pin stop using the plug as shown in the figure

N.B.

THE TOOL FOR INSTALLING THE STOP RINGS MUST BE USED MANUALLY.

CAUTION

USING A HAMMER MIGHT DAMAGE THE STOPS' HOUSING.

Specific tooling

020454Y Tool for fitting piston pin stops (200 - 250)

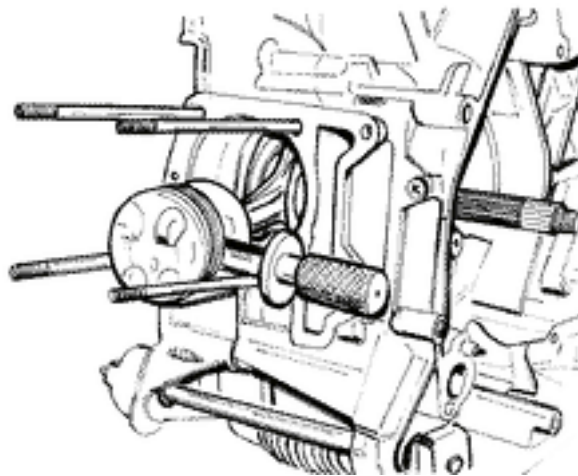

Choosing the gasket

Characteristic

Compression ratio

10.5 ÷ 11.5 : 1

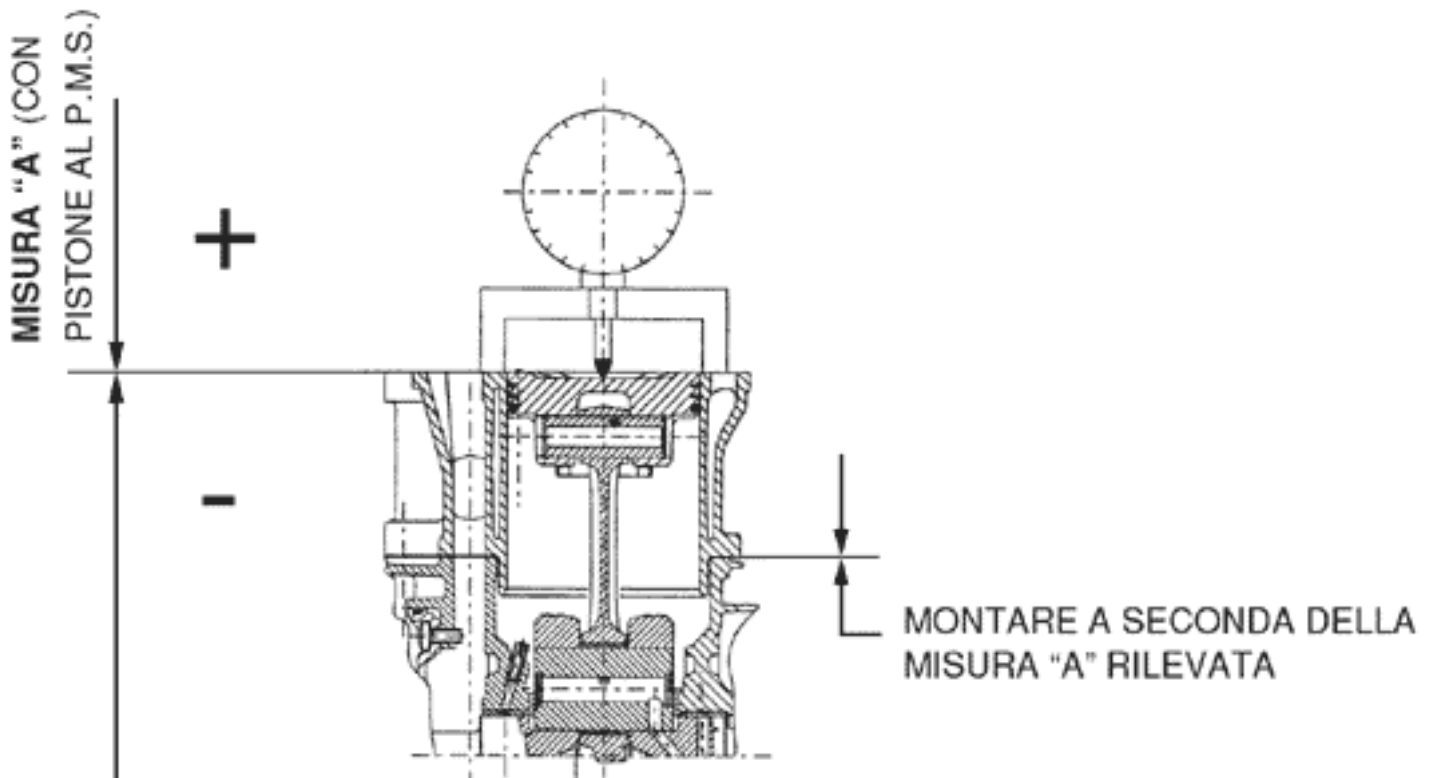

N.B.

MEASUREMENT "A" TO BE TAKEN IS A VALUE OF PISTON RE-ENTRY, IT INDICATES BY HOW MUCH THE PLANE FORMED BY THE PISTON CROWN FALLS BELOW THE PLANE FORMED BY THE TOP OF THE CYLINDER. THE FURTHER THE PISTON FALLS INSIDE THE CYLINDER, THE LESS THE BASE GASKET IS TO BE APPLIED (TO RECOVER THE COMPRESSION RATIO) AND VICE VERSA.

SHIMMING

Name	Measure A	Thickness
shimming	3.70 - 3.60	0.4 ± 0.05
shimming	3.60 - 3.40	0.6 ± 0.05
shimming	3.40 - 3.30	0.8 ± 0.05

Refitting the piston rings

Fitting the sealing rings

- Place the oil scraper spring on the piston.
- Refit the oil scraper ring with the join of spring ends on the opposite side from the ring gap and the word 'TOP' towards the crown of the piston. The chamfered side of the oil scraper ring should always be facing the piston crown.
- Fit the middle piston ring with the identification letter facing the crown of the piston. In any case, the step must be facing opposite the piston top.
- Fit the top piston ring with the word 'TOP' or the reference mark facing the crown of the piston.
- Offset the piston ring gaps on the three rings by 120° to each other as shown in the figure.
- Lubricate the components with engine oil.
- The top piston ring on the 250 engine has an L cross section.

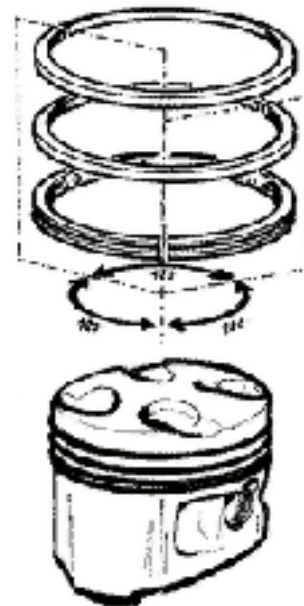

125

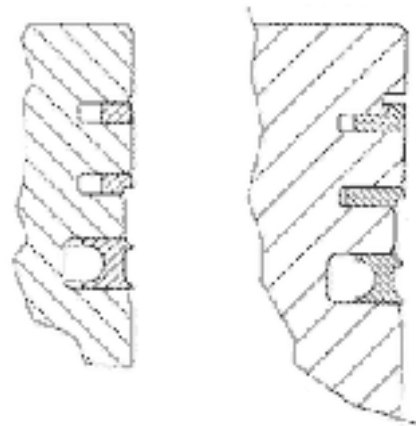

N.B.

THE TWO PISTON RINGS ARE MADE WITH A TAPERED CYLINDRICAL CONTACT CROSS-SECTION. THIS IS TO ACHIEVE A BETTER BEDDING.

Refitting the cylinder

- Insert the cylinder base gasket with the thickness determined above.
- Using the fork support and the piston ring retaining band, refit the cylinder as shown in the figure.

N.B.

BEFORE FITTING THE CYLINDER, CAREFULLY BLOW OUT THE LUBRICATION DUCT AND OIL THE CYLINDER BARREL.

Specific tooling

020426Y Piston fitting fork

020393Y Piston fitting band

020287Y Clamp to assemble piston on cylinder



Inspecting the cylinder head

- Using a trued bar and feeler gauge check that the cylinder head surface is not worn or distorted.

Maximum allowable run-out: 0.05 mm

- Check that the camshaft and the rocker pin capacities exhibit no wear.

- Check that the cylinder head cover surface, the intake manifold and the exhaust manifold are not worn.



Characteristic

bearing «A»

Ø 12.000 - 12.018 mm

bearing «B»

Ø 20.000 ÷ 20.021 mm

bearing «C»

Ø 37.000 - 37.025 mm

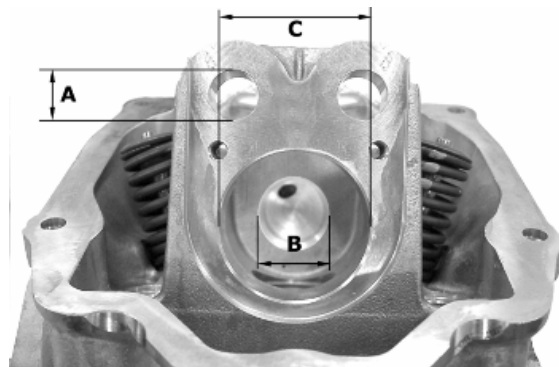

Inspecting the timing system components

- Check that the guide shoe and the tensioner shoe are not worn out.
- Ensure that the camshaft control pulley chain assembly and the sprocket wheel are not worn.
- If you encounter wear, replace the parts or, if the chain, sprocket wheel and pulley are worn replace the whole assembly.
- Remove the centre screw with the washer and the tensioner spring. Check that the one-way mechanism is not worn.
- Check the condition of the tensioner spring.
- If examples of wear are found, replace the whole assembly.

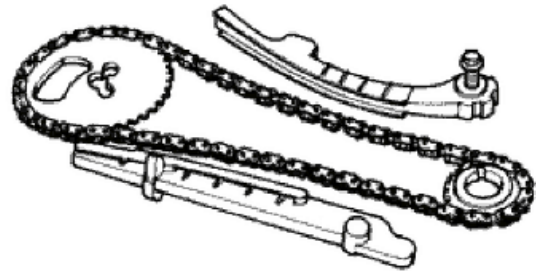

Inspecting the valve sealings

- Insert the valves into the cylinder head.
- Alternatively check the intake and exhaust valves.
- The test is carried out by filling the manifold with petrol and checking that the head does not ooze through the valves when these are just pressed with the fingers.

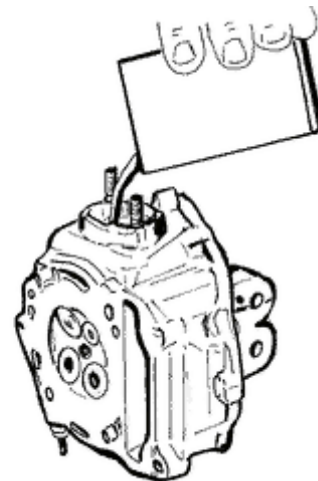

Inspecting the valve housings

- Check the width of the imprint on the valve seat «V» wear limit max. 1.6 mm.
- Remove any carbon formation from the valve guides.
- Measure the inside diameter of each valve guide.
- Take the measurement at three different heights in the rocker arm push direction.
- If the width of the impression on the valve seat or the diameter of the valve guide exceed the specified limits, replace the cylinder head.

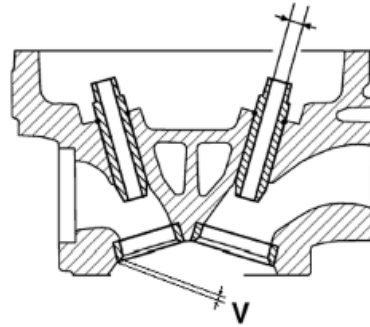

Characteristic

Valve seat wear Intake guide

limit accepted: 5.022

Valve seat wear Exhaust guide

Standard diameter: 5.000 ÷ 5.012 mm

Valve seat wear Exhaust guide

Accepted limit 5.022

Valve seat wear Exhaust guide

Standard diameter: 5.000 ÷ 5.012 mm

Inspecting the valves

- Measure the width of the sealing surface on the valve seats and on the valves.
Sealing surface width: After use: Intake and exhaust: 1.6 mm
- If any of the sealing surfaces on the valves is wider than the specified limit or is damaged in one or more points, or curved, replace the valve with a new one.

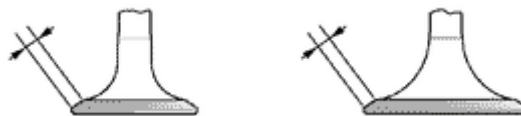

CAUTION

DO NOT REVERSE THE FITTING POSITIONS OF THE VALVES (RIGHT - LEFT).

Characteristic

Valve wear check Standard: Intake and exhaust:

0.99 - 1.27 mm

- Measure the diameter of the valve stems in the three positions indicated in the diagram.

- Calculate the clearance between valve and valve guide.
- Check that there are no signs of wear on the surface of contact with the articulated register terminal.
- If the checks above give no failures, you can use the same valves. For best sealing results, it is advisable to grind the valves. Grind the valves gently with a fine-grained lapping compound. During the grinding, keep the cylinder head with the valve axes in a horizontal position. This will prevent the lapping compound residues from penetrating between the valve stem and the guide (see figure).

CAUTION

TO AVOID SCORING THE FAYING SURFACE, DO NOT KEEP ROTATING THE VALVE WHEN NO LAPPING COMPOUND IS LEFT. CAREFULLY WASH THE CYLINDER HEAD AND THE VALVES WITH A SUITABLE PRODUCT FOR THE TYPE OF LAPPING COMPOUND BEING USED.

N.B.

DO NOT CHANGE THE POSITIONS THE VALVES ARE FITTED IN

Characteristic**Valve check standard length**

Outlet: 94.4 mm

Valve check standard length

Inlet: 94.6 mm

Valve check Maximum admissible clearance

Outlet: 0.072 mm

Valve check Maximum admissible clearance

Inlet: 0.062 mm

Valve check standard clearance

Outlet: 0.025 ÷ 0.052 mm

Valve check standard clearance

Inlet: 0.013 ÷ 0.040 mm

Valve check Minimum admissible diameter

Outlet: 4.95 mm

Valve check Minimum admissible diameter

Inlet: 4.96 mm

Valve check Standard diameter:

Inlet: 4.972 ÷ 4.987 mm

Valve check Standard diameter:

Outlet: 4.96 ÷ 4.975 mm

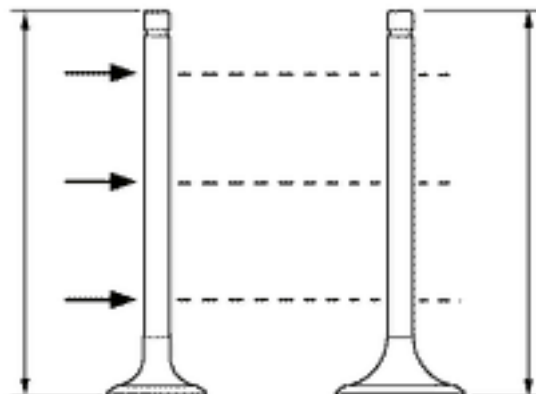

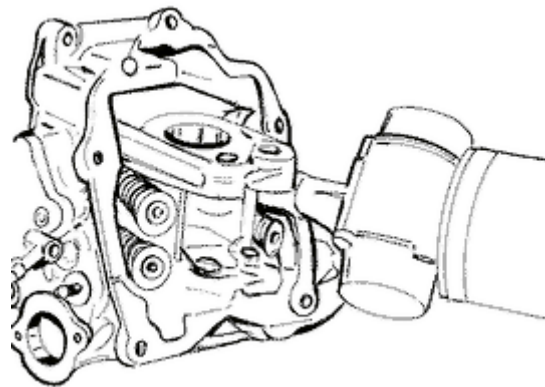
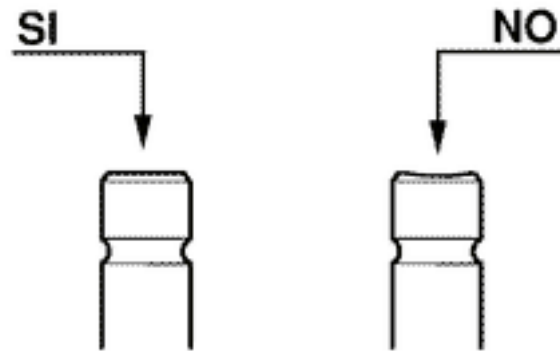

Inspecting the springs and half-cones

- Check that the upper spring caps and the cotter halves show no signs of abnormal wear.

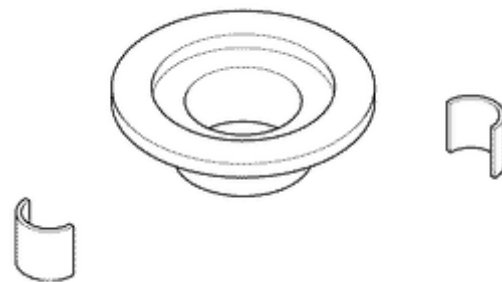

Refitting the valves

- Lubricate the valve guides with engine oil.
- Place the valve spring supports on the head.
- Using the special punch, fit the four valve seals.
- Fit the valves, the springs and the caps. Using the appropriate tool with adapter, compress the springs and insert the cotters in their seats.

N.B.

DO NOT CHANGE THE VALVE FITTING POSITION. FIT THE VALVE SPRINGS WITH THE REFERENCE COLOUR ON COTTER SIDE (TURNS WITH GREATER PITCH).

Specific tooling

020306Y Punch for assembling valve seal rings

020382Y Valve cotters equipped with part 012 removal tool

020382Y011 adapter for valve removal tool



Inspecting the cam shaft

- Inspect the cam shaft for signs of abnormal wear on the cams.
- Check the cam height.
- Check there is no wear on the cam shaft retaining plate and its associated groove on the cam shaft.
- If any of the above dimensions are outside the specified limits, or there are signs of excessive wear, replace the defective components with new ones.
- Check there are no signs of wear on the automatic valve-lifter cam, or the end-of stroke roller, or the rubber buffer on the automatic valve-lifter retaining cover.
- Check that the valve lifting spring has not yielded.
- Replace any defective or worn components.
- Check the rocker pins do not show signs of wear or scoring.

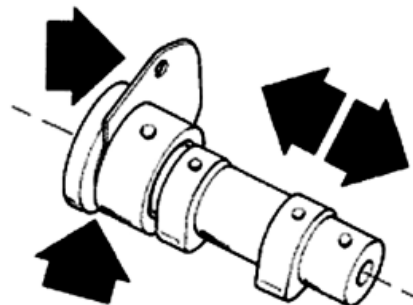
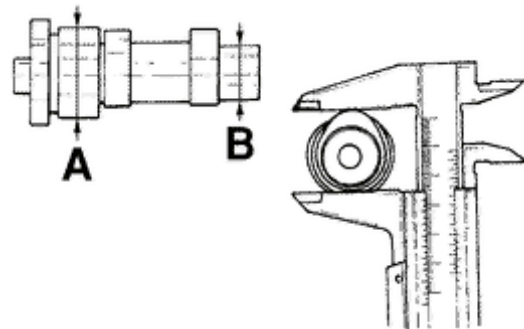

- Measure the internal diameter of each rocker arm.

Check there are no signs of wear on the pad from contact with the cam and on the jointed adjustment plate.

Characteristic

Internal rocker arm diameter: Standard diameter

Diameter 12.000 - 12.011 mm

Rocker arm pin diameter: Standard diameter

Diameter 11.977 - 11.985 mm

Cam shaft check: Maximum admissible axial clearance

0.42 mm

Cam shaft check: Standard axial clearance:

0.11 - 0.41 mm

Cam shaft check: Standard height

Outlet: 29.209 mm

Cam shaft check: Standard height

Inlet: 30.285 mm

Cam shaft check: Minimum admissible diameter

Bearing B diameter: 19.950 mm

Cam shaft check: Minimum admissible diameter

Bearing A Ø: 36.94 mm

Cam shaft check: Standard diameter

Bearing B diameter: 19.959 ÷ 19.98 mm

Cam shaft check: Standard diameter

Bearing A Ø: 36.95 ÷ 36.975 mm

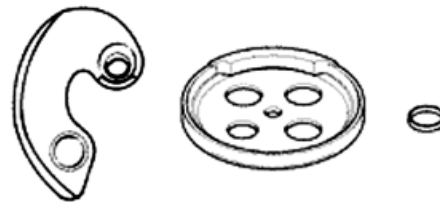

Refitting the head and timing system components

- Fit the timing chain guide pad.
- Insert the centring dowel between the cylinder head to the cylinder, fit the cylinder head gasket and the cylinder head.
- Lubricate the stud bolt threading.
- Tighten up the nuts to an initial pre-torque of 7 ± 1 N·m
- Tighten up the nuts to a second pre-torque of 10 ± 1 N·m
- Rotate by an angle of 270°
- To carry out the operations described above, follow the tightening sequence in the figure.
- Fit the two screws on the outside of the timing chain side and tighten them to the specified torque.

N.B.

BEFORE INSTALLING THE HEAD, MAKE SURE THAT THE LUBRICATION CHANNEL IS CLEAN USING A COMPRESSED AIR JET.

Locking torques (N*m)

Timing chain tensioner support screw $11 \div 13$

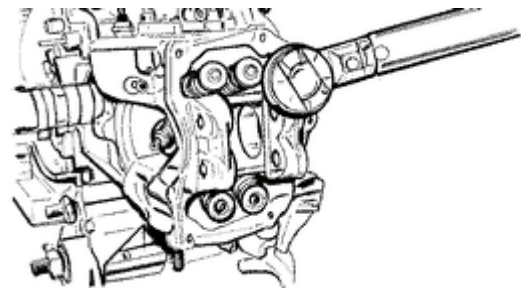
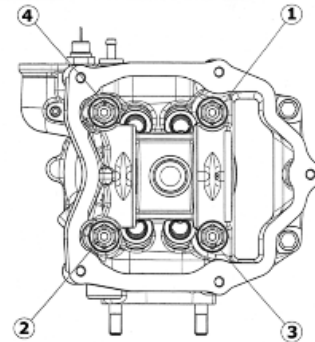

- Refit the lower timing chain sprocket wheel on the crankshaft, with the chamfer facing the insertion side.
- Loop the timing chain around the sprocket on the crankshaft.
- Fit the chain tensioner slider from the cylinder head side.
- Fit the spacer and the screw fastener.
- Tighten the screws to the prescribed torque.
- Fit the pins and rocker arms.
- Lubricate the two rocking levers through the holes at the top.

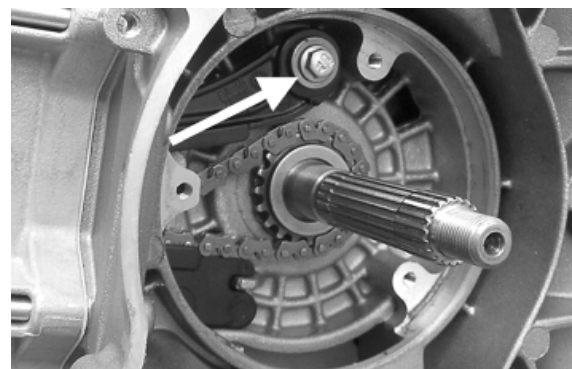

- Lubricate the 2 bearings and insert the cam shaft in the cylinder head with the cams corresponding to the rockers.
- Insert the retention plate and tighten the two screws shown in the figure to the prescribed torque.
- Refit the spacer on the cam shaft.
- Rotate the engine so that the piston is at top dead centre, using the reference marks on the flywheel and the crankcase.
- Holding this position insert the chain on the cam-shaft control pulley.
- Insert the pulley on the cam shaft while keeping the reference **4V** in correspondence with the reference mark on the head.
- Fit the counterweight and tighten the fixing screw to the prescribed torque.
- Fit the end-stop ring on the automatic valve-lifter cam and fit the automatic valve-lifter cam to the cam shaft.
- Fit the automatic valve-lifter return spring.
- During this operation the spring must be loaded by approximately 180°.
- Fit the automatic valve-lifter retaining dish, using the counterweight screw fastener as a reference.
- Tighten the clamping screw to the prescribed torque.
- Set the tensioner cursor in the rest position.
- Fit the chain tensioner on the cylinder, using a new gasket, and tight the two screws to the prescribed torque.
- Insert the chain tensioning screw, together with the spring and washer, tightening it to the prescribed torque.
- Adjust the valve clearance.
- Fit the spark plug.

Electrode distance 0.8 mm

N.B.

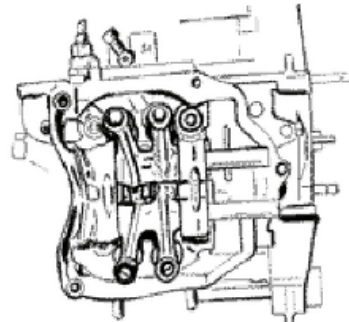
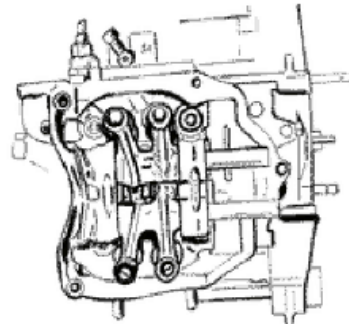

GREASE THE END STOP RING TO PREVENT IT COMING OUT AND FALLING INTO THE ENGINE.

Locking torques (N*m)

Timing chain tensioner support screw 11 ÷ 13
 Spark plug 12 ÷ 14 Starter ground screw 7 ÷
 8.5 Timing chain tensioner slider screw 10 ÷
 14 Starter ground support screw 11 ÷ 15 Timing
 chain tensioner central screw 5 - 6 Camshaft
 retention plate screw 4 ÷ 6

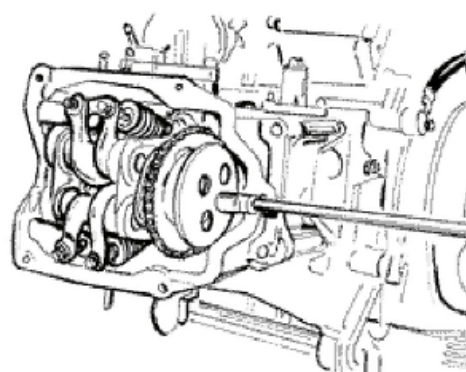
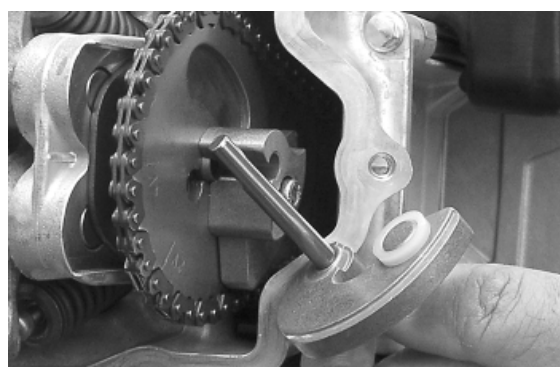
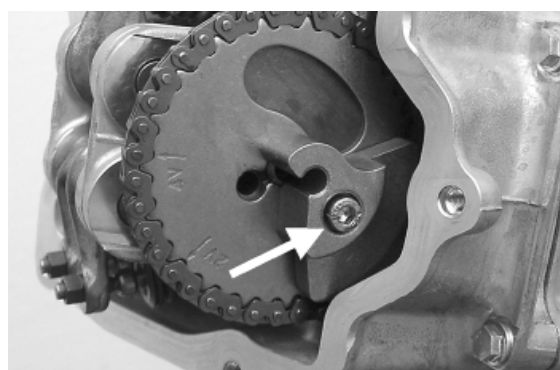

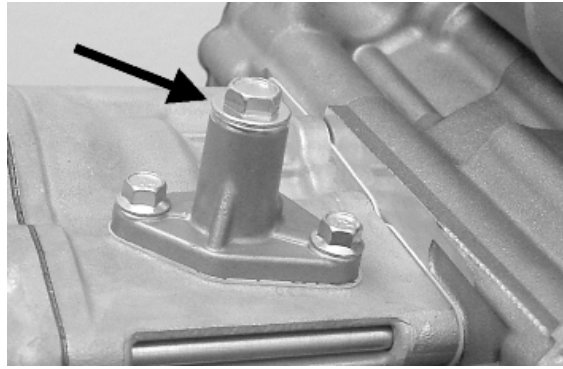

Refitting the rocker-arms cover

- Refit the cylinder head cover, tightening the 5 clamping screws to the prescribed torque.
- Make sure the gasket is positioned properly.

Locking torques (N*m)

Tappet cover screws 6 - 7 Nm

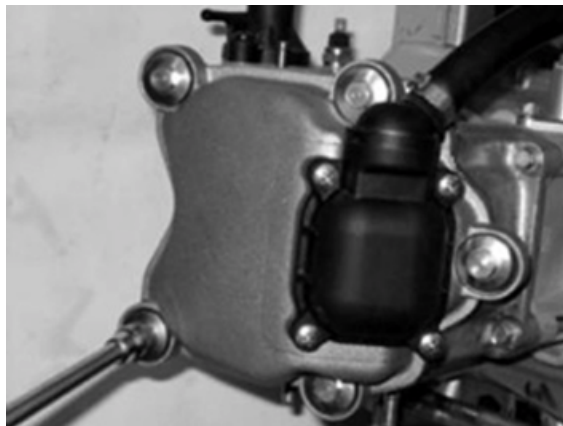

Refitting the intake manifold

Fit the intake manifold and do up the three screws.

N.B.

USE COMMERCIALY AVAILABLE INSERTS AND INSERT HOLDERS FOR THE SPECIAL SCREWS FOR 125 CM³ MODELS.

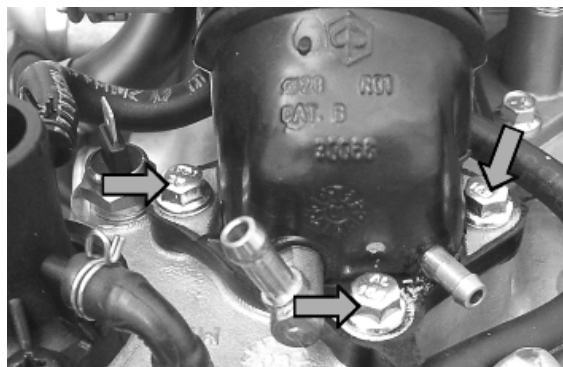

Crankcase - crankshaft

Splitting the crankcase halves

- Before opening the crankcase, it is advisable to check the axial clearance of the crankshaft. To do this, use a plate and a support with appropriate tool dial gauge.
- Upper clearances are an indication of wear on the surfaces of the crankshaft casing support.
- Remove the 10 crankshaft coupling screws.
- Separate the crankcase while keeping the crankshaft in one of the two halves of the crankcase.
- Remove the crankshaft.
- Remove the half crankcase coupling gasket.
- Remove the two screws and the internal cover shown in the diagram.
- Remove the oil guard on the flywheel side.
- Remove the oil filter fitting shown in the diagram.
- Check the axial clearance on the connecting rod.
- Check the radial clearance on the connecting rod.
- Check the surfaces that limit the axial free-play are not scored and measure the width of the crankshaft between these surfaces, as shown in the diagram.
- If the axial clearance between crankshaft and crankcase is exceeding and the crankshaft does not have any defect, the problem must be due to either excessive wear or wrong machining on the crankcase.
- Check the diameters of both the bearings of the crankshaft in accordance with the axes and surfaces shown in the figure. The half-shafts are classified in two categories Cat. 1 and Cat. 2 as shown the chart below.

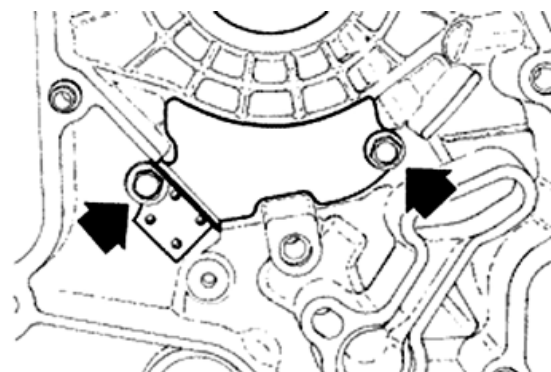
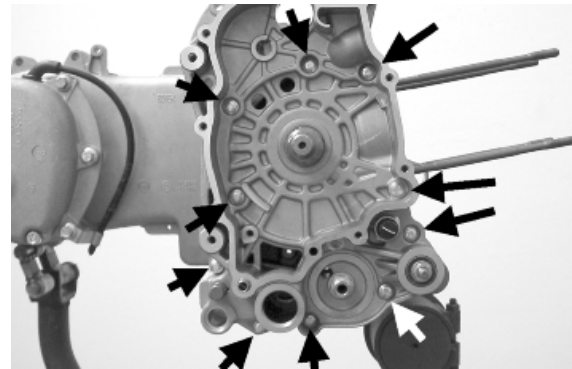
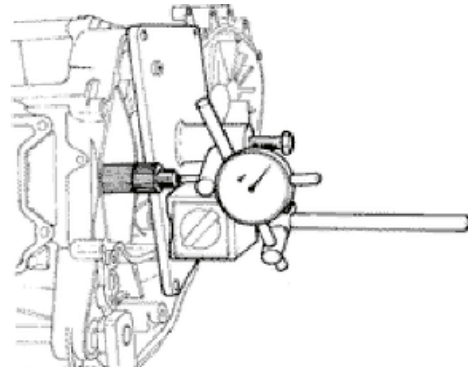

CAUTION

THE CRANKSHAFT CAN BE REUSED WHEN THE WIDTH IS WITHIN THE STANDARD VALUES AND THE SURFACES SHOW NO SIGNS OF SCORING.

CAUTION

WHILE OPENING THE CRANKCASES AND REMOVING THE DRIVING SHAFT, CHECK THAT

THE THREADED SHAFT ENDS DO NOT INTERFERE WITH THE MAIN BUSHINGS. FAILURE TO OBSERVE THIS PRECAUTION CAN DAMAGE THE MAIN BUSHINGS.

CAUTION

KEEP THE CRANKSHAFT IN ONE OF THE TWO HALVES OF THE CRANKCASE WHEN SEPARATING IT. IF YOU FAIL TO DO THIS, THE CRANKSHAFT MIGHT ACCIDENTALLY FALL.

N.B.

WHEN MEASURING THE WIDTH OF THE CRANKSHAFT, MAKE SURE THAT THE MEASUREMENTS ARE NOT MODIFIED BY THE RADIIUSES OF FITTINGS WITH THE CRANKSHAFT BEARINGS.

Specific tooling

020262Y Crankcase splitting strip

020335Y Magnetic support for dial gauge

Characteristic

Axial crankshaft/crankcase clearance: Standard clearance

0.15 - 0.40 mm (when cold)

Axial connecting rod - crankshaft clearance Standard clearance

0.20 ÷ 0.50 mm

Radial connecting rod - crankshaft clearance Standard clearance

0.036 ÷ 0.054 mm

Width of crankshaft with integral washers: standard measurements

55.67 ÷ 55.85 mm

Crankshaft bearings: Standard diameter: Cat. 1

28.994 ÷ 29.000

Crankshaft bearings: Standard diameter: Cat. 2

29.000 ÷ 29.006

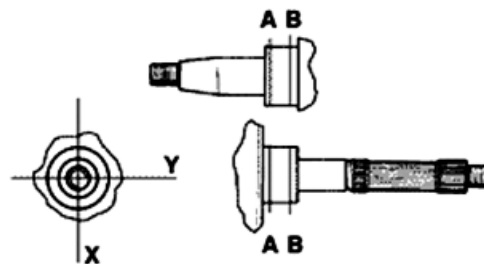
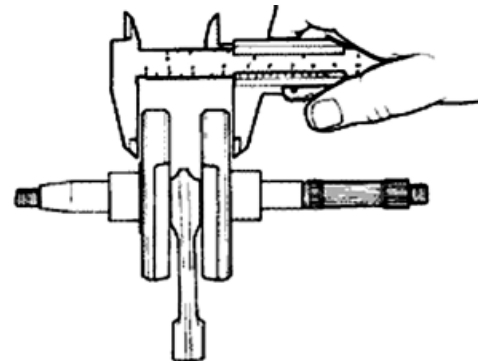
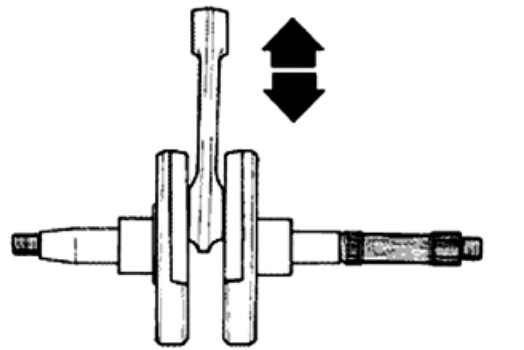

Inspecting the crankshaft alignment

To install the drive shaft on the support and to measure the misalignment in the 4 points indicated in figure.

- Check that the driving shaft cone, the tab seat, the oil seal capacity, the toothed gear and the threaded tangs are in good working order.
- In case of failures, replace the crankshaft.

The connecting rod head bushings cannot be replaced. For the same reason, the connecting rod may not be replaced and, when cleaning the crankshaft, be very careful that no impurities get in through the shaft's lubrication holes.

In order to prevent damaging the connecting rod bushings, do not attempt cleaning the lubrication duct with compressed air.

- Make sure that the 2 caps on the crankpin are properly fitted.
- A wrong installation of a cap can seriously affect the bushing lubrication pressure.

N.B.

THE MAIN BEARINGS ARE NOT GRINDABLE

Specific tooling

020074Y Support base for checking crankshaft alignment

Characteristic

Off-line maximum admitted

A = 0.15 mm

B = 0.01 mm

C = 0.01 mm

D = 0.10 mm

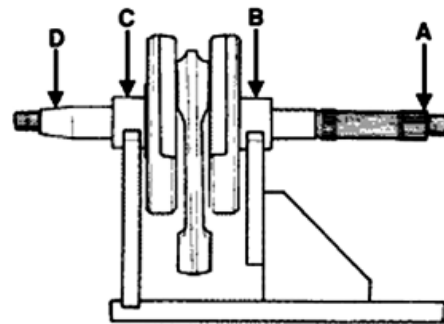

Inspecting the crankcase halves

- Before proceeding to check the crankcase halves, thoroughly clean all surfaces and oil ducts.
- On the transmission-side crankcase half, take particular care when handling the oil pump compartment and the oil ducts, the by-pass duct, the main bushings and the cooling jet on the transmission side (see diagram).
- Take particular care, also, that there are no signs wear in the oil by-pass valve housing (see Chapter Lubrication), as this could prevent a good seal in the valve, which regulates the oil pressure.
- On the flywheel side crankcase half, take particular care cleaning the oil ducts for the main bushings, the oil duct for the jet that lubricates the cylinder head and the oil drainage duct at the flywheel side oil seal.
- Inspect the coupling surfaces on the crankcase halves for scratches or deformation, taking particular care with the cylinder/crankcase surfaces and the crankcase halves surfaces.
- Defects in the crankcase coupling gasket between the crankcase halves or the mating surfaces shown in the diagram, could cause a drop in the oil pressure lubricating the main bearings and connection rod.
- Check the main bearing seats that limit axial clearance in the crankshaft show no signs of wear. The dimension between these seats is measured by way of the procedure described previously for measuring the crankshaft axial clearance and dimensions.

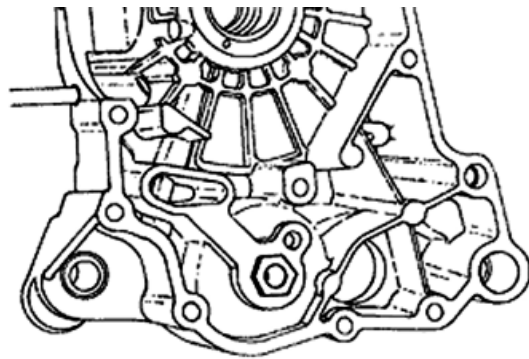
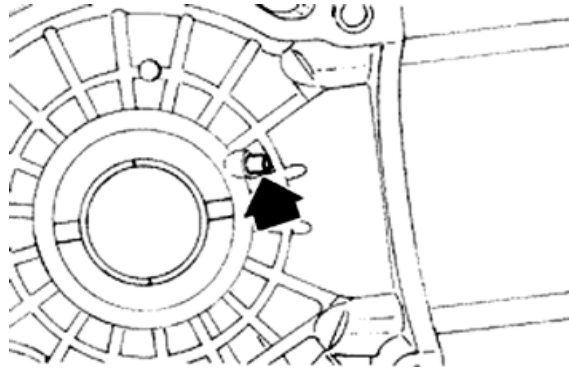

N.B.

THE JET IS FED THROUGH THE MAIN BUSHINGS. PROPER OPERATION OF THIS COMPONENT IMPROVES THE PISTON TOP COOLING. CLOGGING HAS EFFECTS THAT ARE DIFFICULT TO DETECT (PISTON TEMPERATURE INCREASE). FAILURE OR LEAK CAN CONSIDERABLY DECREASE THE MAIN BUSHING

AND CONNECTING ROD LUBRICATION PRESSURE.**N.B.**

THE HEAD LUBRICATION CHANNEL IS PROVIDED WITH A SHUTTER JET; THIS GIVES A "LOW PRESSURE" HEAD LUBRICATION; THIS CHOICE WAS MADE TO REDUCE THE OIL TEMPERATURE IN THE SUMP. THE JET CLOGGING IMPAIRS THE HEAD LUBRICATION AND THE TIMING MECHANISMS. A JET FAILURE CAUSES A DECREASE OF THE MAIN BUSHING AND CONNECTING ROD LUBRICATION PRESSURE.

Inspecting the crankshaft plain bearings

- T

o obtain a good bushing lubrication it is necessary to have both an optimal lubricating pressure (3,2 bar) and a good oil flow rate; the bushings must be correctly positioned so as not to obstruct the oil supply channels.

- The main bushings are comprised of two half-bearings, one with holes and channels for lubrication whereas the other is solid.

- The solid half-bearing is intended to stand the thrusts caused by combustion, and for this reason it is arranged opposite the cylinder.

- To prevent obstructions in the oil feeding channels, the matching surface of the two half-bearings must be perfectly perpendicular to the cylinder axis, as shown in the figure.

- The oil feeding channel section is also affected by the bushings driving depth compared with the crankshaft axial clearance of the limiting surface.

- Check the inside diameter of the main bushings in the three directions indicated in the diagram.

- Repeat the measurements for the other bushing half. see diagram.

- There are three crankcase versions: with RED main bushings, with BLUE main bushings and with YELLOW main bushings.

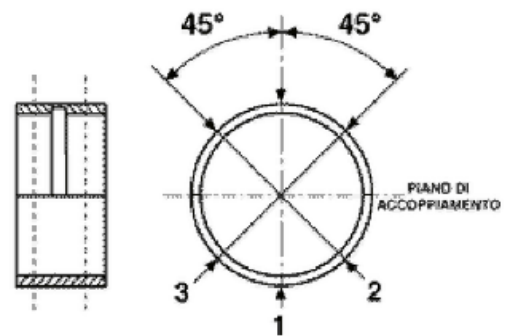
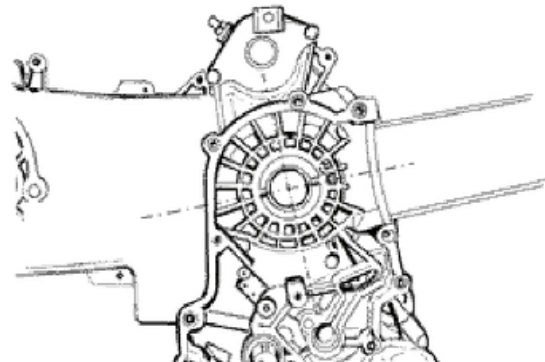

- There is only one type of main bushing housing hole in the crankcase

The standard bushing diameter after driving is variable on the basis of a coupling selection.

- The bushing housings in the crankcase are available in two categories, Cat. 1 and Cat. 2, as are the crankshafts.

- The main bushings are available in three thickness categories, identified by colour markings, as shown in the table below.

TYPE		IDENTIFICATION	
A		RED	
B		BLUE	
C		YELLOW	

	Type "A" - RED	Type "B" - BLUE	Type "C" - YEL- LOW
Crankshaft	1.970 ÷	1.9703 ÷	1.976 ÷
half-bearing	1.973	1.976	1.979

Bush- ing cat- egory	Crank- case halves category	Internal bush- ing diameter after fitting	Possible fitting
A	1	29.025 ÷ 29.040	Original
B	1	29.019 ÷ 29.034	Original and spare
	2	29.028 ÷ 29.043	
C	2	29.022 ÷ 29.037	Original

Match the shaft with two category 1 crank webs with the category 1 crankcase (or cat. 2 with cat. 2) Furthermore a spare crankcase cannot be matched with a crankshaft with mixed categories. The spare crankshaft has half shafts of the same category.

Crankcase halves	Engine half shaft	Bushing
Cat. 1	Cat. 1	B
Cat. 2	Cat. 2	B
Cat. 1	Cat. 2	A
Cat. 2	Cat. 1	C

N.B.

TO KEEP THIS POSITION OF THE BUSHINGS ON THE CRANKCASE, FITTING IS FORCED ON STEEL RINGS INSERTED IN THE CASTING OF BOTH CRANKCASE HALVES.

N.B.

DO NOT TAKE THE MEASUREMENT ON THE TWO HALF-SHELL COUPLING SURFACE SINCE THE ENDS ARE RELIEVED TO ALLOW BENDING DURING THE DRIVING OPERATION.

N.B.

CRANKCASES FOR REPLACEMENTS ARE SELECTED WITH CRANKCASE HALVES OF THE SAME CATEGORY AND ARE FITTED WITH CATEGORY B BUSHINGS (BLUE)

Characteristic

Standard driving depth

1.35 ÷ 1.6

Diameter of crankcase without bushing

32.953 ÷ 32.963

Refitting the crankcase halves

- Fit the internal bulkhead by locking the two screws to the prescribed torque.
- Fit the oil filter fitting and tighten it to the specified torque.
- Place a new gasket on one of the crankcase halves, preferably on the transmission side, together with the locating dowels.
- Lubricate the main bushings and insert the crankshaft in the transmission side crankcase half.
- Reassemble the two crankcase halves.
- Fit the 10 screws and tighten them to the prescribed torque.
- Fit a new O-ring on the pre-filter and lubricate it.

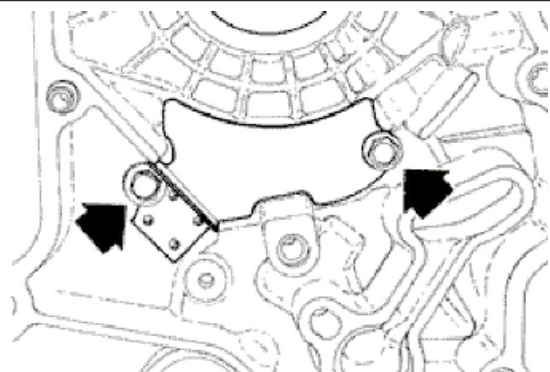

- Insert the filter on the engine with the relative cap.
Tighten to the prescribed torque.

Locking torques (N*m)

Internal engine crankcase bulkhead (transmission-side half shaft) screws 4 ÷ 6 Engine-crankcase coupling screws 11 ÷ 13 Oil filter on crankcase fitting 27 ÷ 33 Engine oil drainage plug/mesh filter 24 ÷ 30

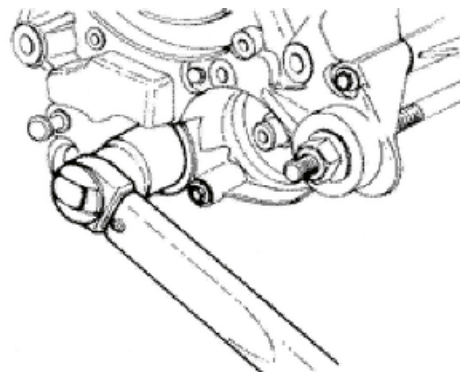
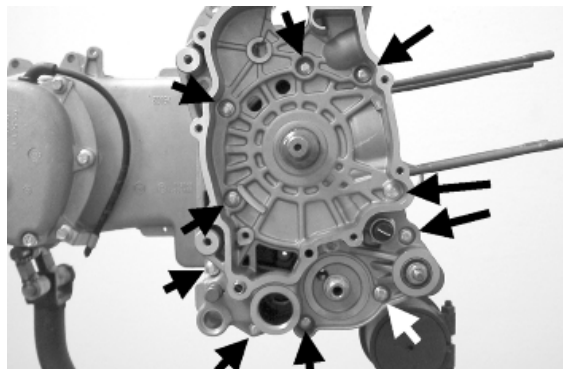
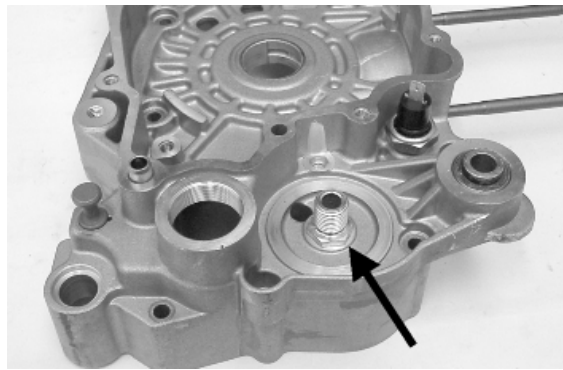

Lubrication

Conceptual diagrams

LUBRICATION CIRCUIT

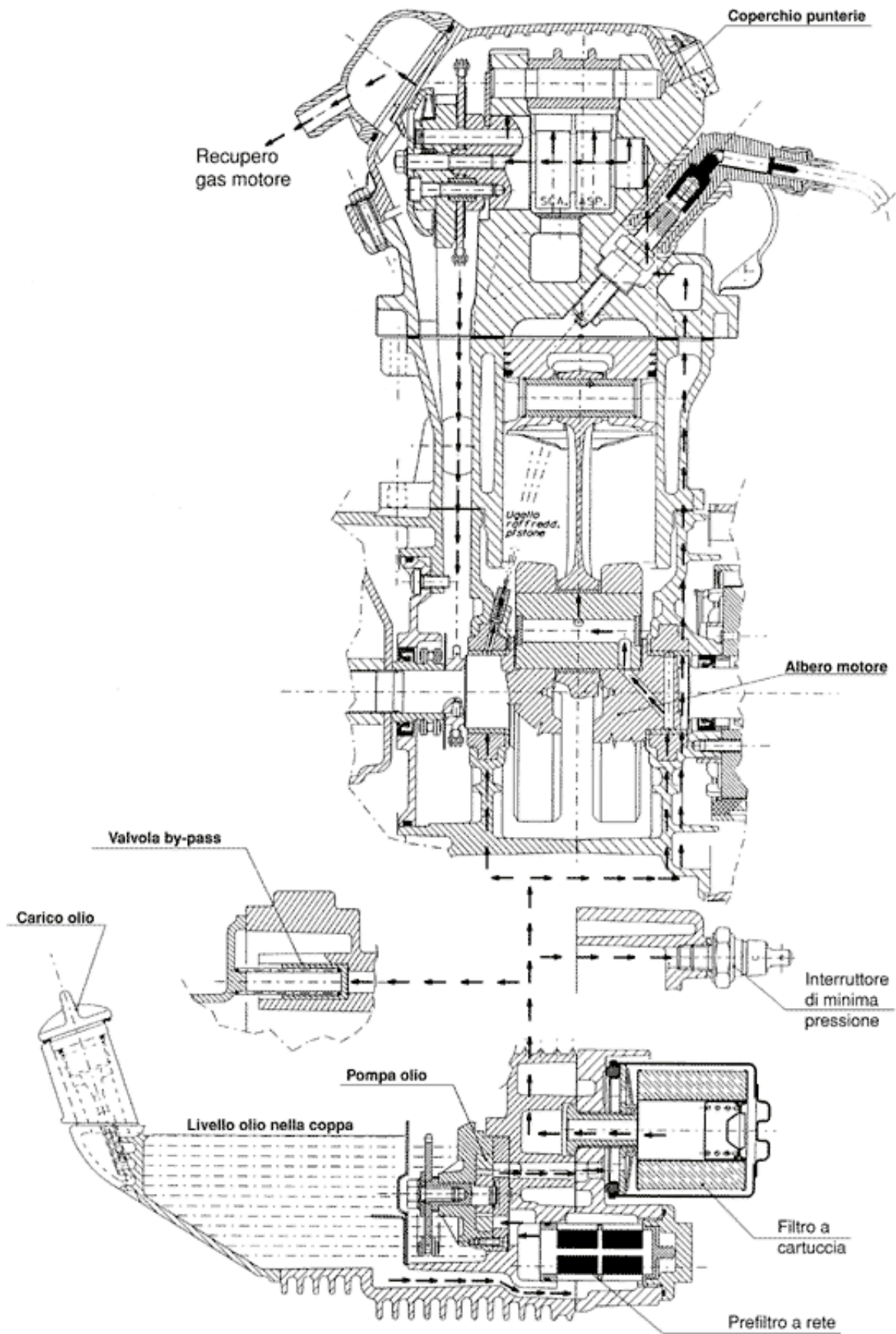

Oil pressure check

- After removing the flywheel cover as described in the "Flywheel" chapter, remove the electric connexion of the minimum oil pressure switch and then remove the switch.
- With the engine idling at 1650 rpm and the oil temperature at $\sim 90^{\circ}\text{C}$, check that the oil pressure is between $0.5 \div 1.2$ atm.
- With the engine idling at 6000 rpm and the oil temperature at $\sim 90^{\circ}\text{C}$, check that the oil pressure is between $3.2 \div 4.2$ atm.
- Remove the appropriate tools once the measurement is complete, refit the oil pressure switch and washer, tightening it to the specified torque and fit the fan cover.
- If the oil pressure is not within the specified limits, in the following order, check: the oil filter, the oil by-pass valve, the oil pump and the crankshaft seals.

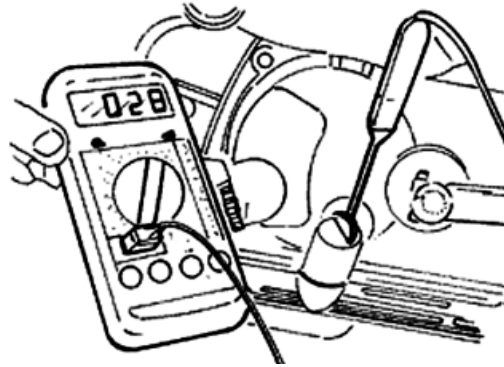

N.B.

THE CHECK MUST BE CARRIED OUT WITH OIL AT THE CORRECT LEVEL AND WITH AN OIL FILTER IN GOOD CONDITION.

Characteristic

Oil pressure

Minimum pressure admitted at 6000 rpm: 3.2 atm.

Locking torques (N*m)

Minimum oil pressure sensor $12 \div 14$



Crankshaft oil seals

Removal

- First remove the transmission cover and the complete driving pulley

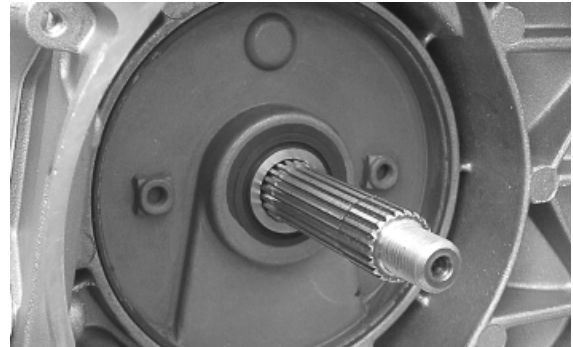

- Install the base of the appropriate tool on the oil guard using the screws provided.

Specific tooling

020622Y Transmission-side oil guard punch

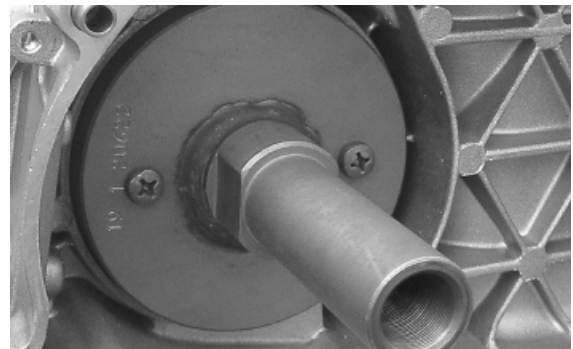

- Screw the threaded bar onto the base of the tool and extract the oil guard.

Specific tooling

020622Y Transmission-side oil guard punch

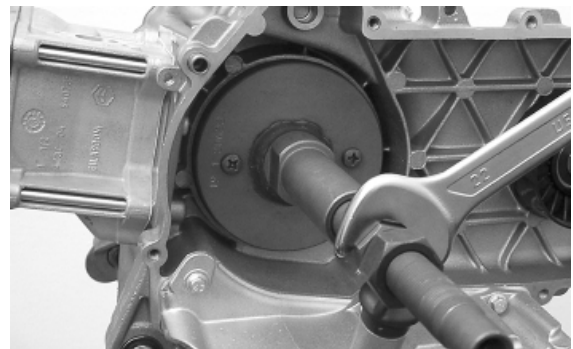

Refitting

- Use a new oil seal upon refitting.
- Prepare the new oil seal, lubricating the sealing lip.
- Preassemble the oil seal with the specific tool, positioning the screws.
- Place the sheath over the crankshaft.
- Insert the tool with the oil seal on the crankshaft until it comes into contact with the crankcase.
- Orientate the oil seal by inserting the bracket which is part of the specific tool.
- Tighten the threaded bar onto the crankshaft as far as it will go.
- Use the nut to move the base of the tool until you can feel the end of the oil seal driving stroke.
- Remove all of the tool components following the inverse procedure

CAUTION

DO NOT LUBRICATE THE SURFACE FOR KEYING ONTO THE ENGINE CRANKCASE.

CAUTION

ORIENT THE OIL GUARD BY POSITIONING THE CHAIN HOUSING CHANNEL FACING DOWNWARDS. WHEN THE POSITION IS REACHED, DO NOT RETRACT THE OIL GUARD. FAILURE TO COMPLY WITH THIS RULE CAN CAUSE A WRONG POSITIONING OF THE OIL GUARD SHEATH.

CAUTION

FAILURE TO COMPLY WITH THIS ASSEMBLY PROCEDURE CAN SERIOUSLY DAMAGE THE ENGINE DUE TO THE WRONG TENSIONING OF THE OIL PUMP CONTROL CHAIN.

Specific tooling

020622Y Transmission-side oil guard punch



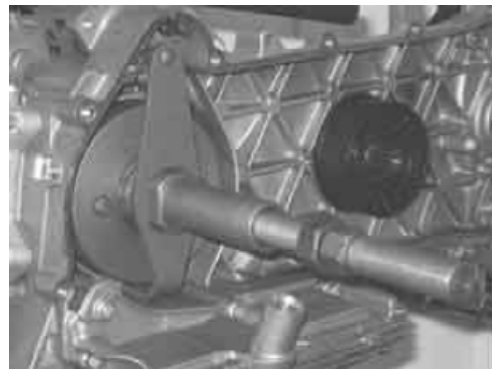

Oil pump

Removal

- Undo the two clamping screws in the figure and remove the cover over the pump control crown.

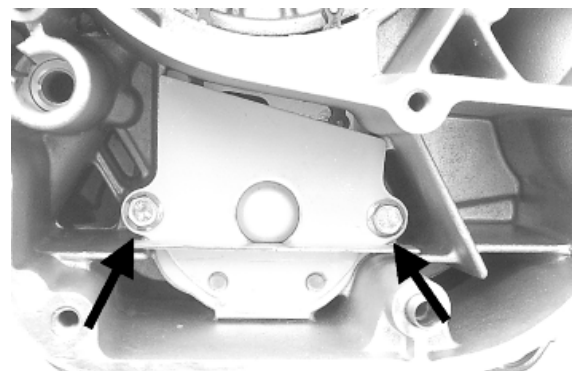

- Block the rotation of the oil pump control pulley with a screwdriver inserted through one of its two holes.

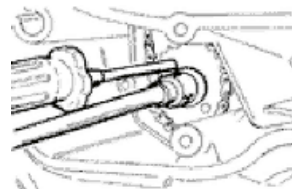

- Remove the central screw with Belleville washer, as shown in the diagram.

- Remove the chain with the crown.

- Remove the control sprocket with relative O-ring.

- Remove the oil pump by unscrewing the two screws in the figure.

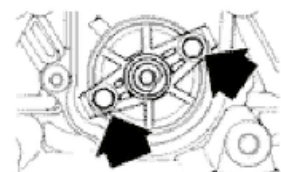

- Remove the oil pump seal.

N.B.

IT IS ADVISABLE TO MARK THE CHAIN IN ORDER TO ENSURE THAT THE INITIAL DIRECTION OF ROTATION IS MAINTAINED.

Inspection

- Remove the two screws and the oil pump cover.
- Remove the clip retaining the innermost rotor.
- Remove and wash the rotors thoroughly with petrol and compressed air.
- Reassemble the rotors in the pump body, keeping the two reference marks visible. Replace the clip.
- Check the clearance between the rotors in the position shown in the diagram.

Measure the distance between the outer rotor and the pump body (see figure).

- Check the axial clearance of the rotors using a tried bar as shown in the figure.

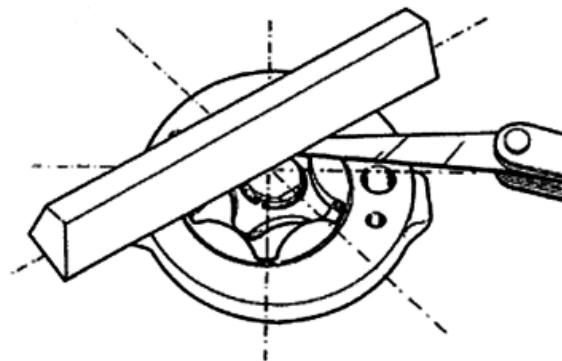
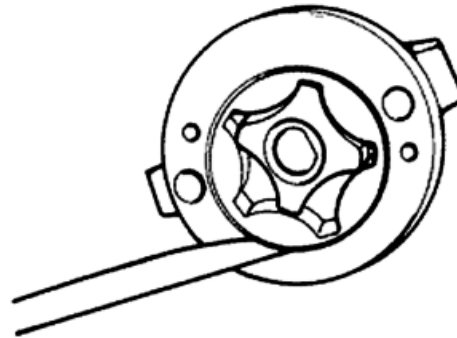
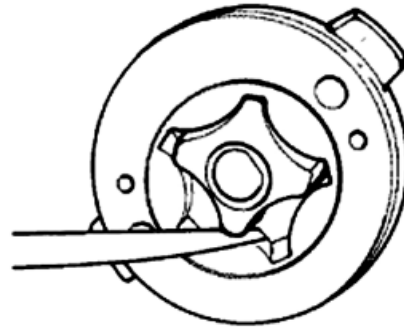

Characteristic

Axial rotor clearance

Limit values admitted: 0.09 mm

Distance between the outer rotor and the pump body

Admissible limit clearance: 0.20 mm

Distance between the rotors

Admissible limit clearance: 0.12 mm



Refitting

- Check there are no signs of wear on the oil pump shaft or body.
- Check there are no signs of scoring or wear on the oil pump cover.
- If you detect non-conforming measurements or scoring, replace the faulty parts or the unit.
- Fit the pump cover in the position that permits the crankcase fixing screws to be aligned.
- Make sure the gasket is positioned properly and refit the pump on the engine crankcase. The pump can only be fitted in one position.
- Tighten the screws to the prescribed torque.
- Fit the sprocket wheel with a new O-ring.
- Fit the chain.
- Fit the central screw and the belleville washer. Tighten to the prescribed torque.
- Fit the oil pump cover by tightening the two screws to the prescribed torque.

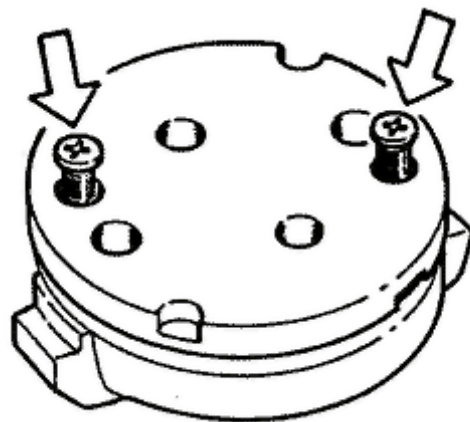

N.B.

FIT THE BELLEVILLE WASHER SO THAT ITS OUTER RIM TOUCHES THE PULLEY. MAKE SURE THAT THE PUMP TURNS FREELY.

Locking torques (N*m)

**Screws fixing oil pump to the crankcase 5 - 6
Oil pump control crown screw 10 ÷ 14
Oil pump cover screws 0.7 ÷ 0.9**

Removing the oil sump

- Remove the oil filler plug, the transmission cover, the complete driving pulley assembly with belt and the sprocket wheel, as described in the "Transmission" chapter.
- Drain the oil as described previously.
- Remove the seven screws, shown in the diagram, and the two rear brake fluid pipe fixing brackets.
- Remove the screw, the by-pass piston, the gasket and centring dowels shown in the figure.

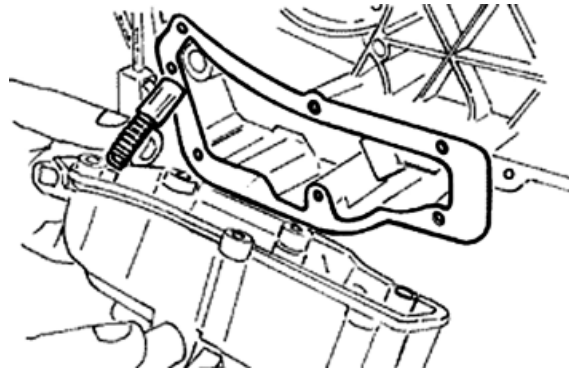
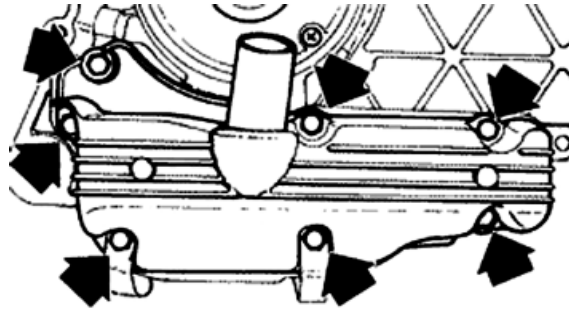

Inspecting the by-pass valve

- Check the unloaded spring length.
- Check that the small piston is not scored.
- Ensure that it slides freely on the crankcase and that it guarantees a good seal.
- If not, eliminate any impurities or replace defective parts.

Characteristic

By-pass check up: Standard length

54.2 mm

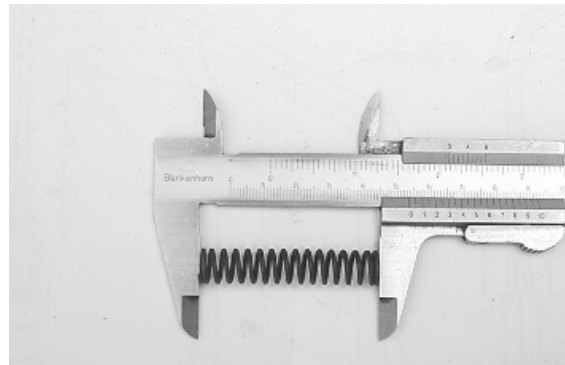

Refitting the oil sump

- Refit the by-pass valve plunger in its housing.
- Insert the pressure-regulating spring.
- Fit a new sump seal.
- Refit the two centring dowels.
- Refit the sump, taking care to locate the spring in the appropriate recess machined into the inside of the sump.
- Refit the rear brake cable brackets and the screws in the reverse order from which they were removed.
- Tighten the screws to the prescribed torque.
- Refit the drive pulley assembly, the drive belt, the sprocket wheel and the transmission cover, as described in the "Transmissions" chapter.
- **When testing the lubrication system, refer to chapter "Crankcase and Crankshaft", regarding lubrication of the crankshaft and connecting rod**

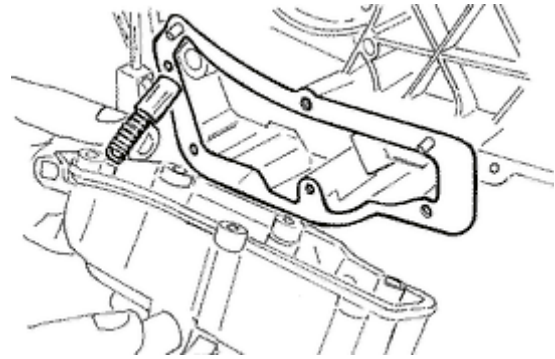

Locking torques (N*m)

Oil sump screws 10 ÷ 14

SAS valve

Inspecting the one-way valve

- Remove the SAS valve.
- Provisionally assemble the rubber coupling of the SAS valve outlet to ensure tightness.
- Connect the MITYVAC vacuum pump to the rubber coupling as shown in the photograph.
- Set the pump to the low-pressure position (VACUUM).
- Operate the pump slowly.
- Check that the one way valve allows the air to pass through causing a slight vibration.



- Switch the pump to pressure mode (PRES-SURE).
- Operate the pump slowly and check if there is an increase of pressure. A small leakage is considered to be normal.

If anomalies are detected, replace the pump.

N.B.

A MALFUNCTIONING ONE-WAY VALVE CAN RESULT IN RUBBER COUPLING AND FILTER OVERHEATING

N.B.

ABSENCE OF VIBRATION INDICATES INEFFICIENT SEALING

Specific tooling

020329Y MityVac vacuum-operated pump

Inspecting the cut-off

- Remove the SAS valve.
- Connect the MITYVAC pump in low-pressure mode (VACUUM) to the CUT-OFF valve vacuum intake.
- Apply a vacuum value higher than 0.5 BAR.
- Check that this value is kept all the time.
- If a worn seal is detected, replace it.
- With a "T" bypass and flexible rubber hoses make a parallel connection between the rubber coupling and the vacuum intake of the CUT-OFF valve.
- Connect the bypass to the MITYVAC pump.
- Set the pump set to the low-pressure mode (VACUUM).
- Using a pair of long flat pliers, choke the rubber hose next to the valve.
- Operate the pump until vacuum is higher than 0.5 BAR.
- Release the hose and check how the vacuum reacts. - Under normal functioning conditions the vacuum undergoes a slight fall and then readjusts. There follows a slow and continuous loss of depression up to approximately 0.4 BAR. At this point



the valve opens and the depression is suddenly set to zero.

Lack of tightness or the fact that the valve opens at different vacuum values should be regarded as anomalies. In this case, replace it.

N.B.

LACK OF TIGHTNESS IN THE CUT-OFF VALVE RESULTS IN EXHAUST NOISE (EXPLOSIONS IN THE MUFFLER). INCORRECT CUT-OFF VALVE CALIBRATION CAN RESULT IN CATALYTIC CONVERTER MALFUNCTIONING

N.B.

A FAULTY CUT-OFF VALVE DIAPHRAGM, BESIDES JEOPARDISING THE CORRECT OPERATION OF THE CUT-OFF VALVE, ALSO DAMAGES IDLE FUNCTIONING

Specific tooling

020329Y MityVac vacuum-operated pump



Fuel supply

Removing the carburettor

Kehin

- To detach the carburettor from the engine, it is necessary to move the air filter and remove the transmission throttle control, the automatic starter connection, the clamps anchoring the carburettor to the filter housing and to the inlet manifold, the air delivery pipe to the diaphragm, and the intake fitting.

- Take out the carburettor and rotate it so as to remove the screw with the water joint and the pipes.

N.B.

THIS LAST OPERATION IS NECESSARY SO AS NOT TO EMPTY THE COOLING SYSTEM.



-
- Remove the protection, the bracket and the starter acting on the screw shown in the figure.

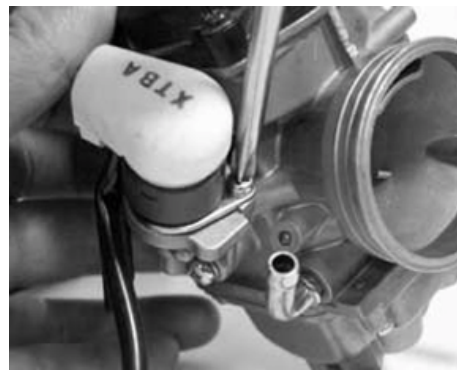

-
- Remove the 2 screws and the starter support with the gasket.



-
- Remove the clamp and cover with the airing filter of the diaphragm chamber.

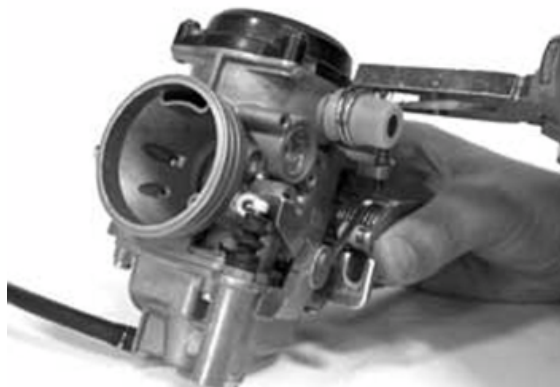

-
- Remove the 4 fixing screws shown in the figure and the vacuum chamber cover.

WARNING

DURING THE REMOVAL OF THE CARBURETOR COVER TAKE SPECIAL CARE NOT TO RELEASE THE SPRING ACCIDENTALLY.





- Remove the vacuum valve together with the diaphragm.



- Unscrew the bayonet joint 1/8 of a turn and remove, take out the spring and vacuum valve needle

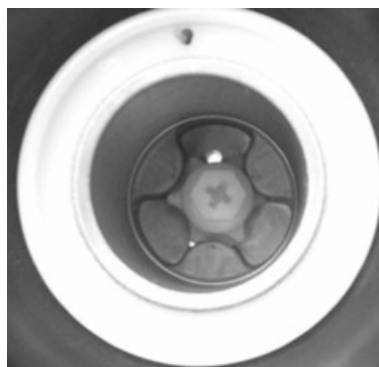

- Remove the 4 screws indicated in the figure.



- Remove the chamber with the accelerating pump, its control and gasket.



- Remove the oil pump seal.
- Remove the intake and outlet valves of the intake pump from the tank

N.B.

CAUTION, THE ACCELERATION PUMP VALVES ARE MADE UP OF NOZZLES, SPRING AND BALL.

N.B.

AVOID REMOVING THE PISTON OF THE PUMP AND ITS CONTROL.



Adequately support the carburettor and using a rod and hammer remove the float pin acting from the throttle control side.

- Remove the float and the plunger.
- Remove the maximum nozzle



-Remove the maximum nozzle.

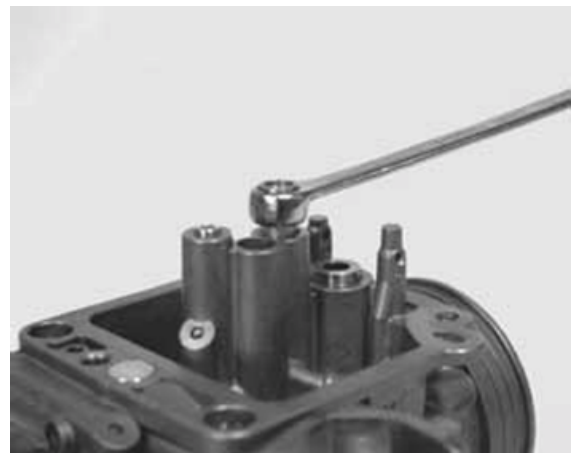

-Remove diffuser.

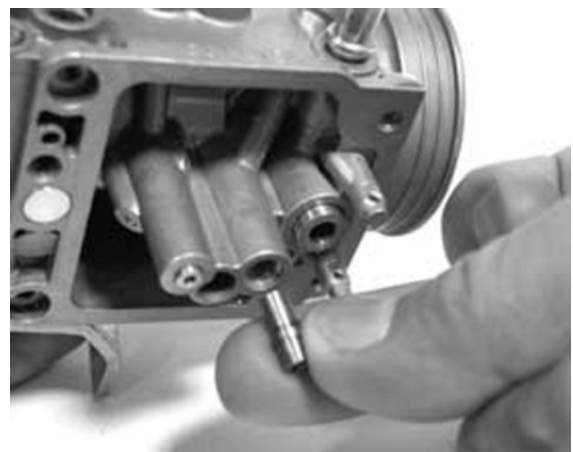

-
- Remove the sprayer.

N.B.

WHEN CLEANING THE CARBURETTOR BODY REMOVE THE SPRAYER TO AVOID LOSING PARTS. IF THE SPRAYER IS FORCED IN ITS HOUSING DO NOT ATTEMPT TO REMOVE IT AS THIS WILL ONLY DAMAGE IT.

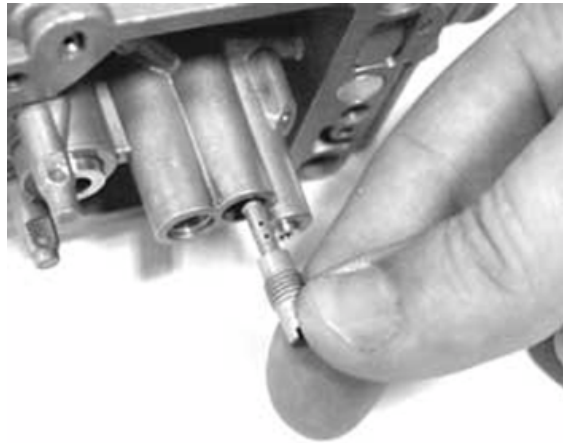

-
- Remove the minimum nozzle.

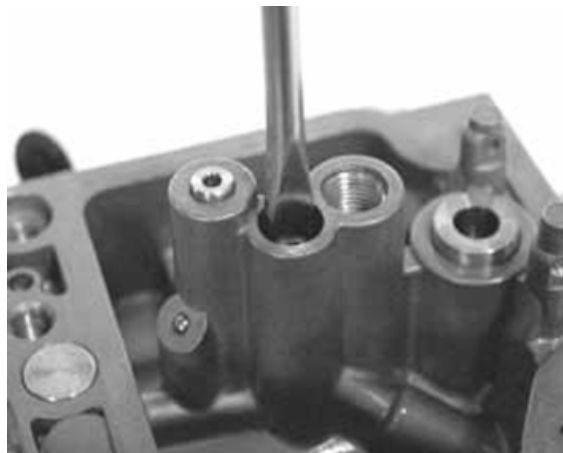

-
- Remove the minimum flow set screw and the spring.

CAUTION

DO NOT ATTEMPT REMOVING PARTS EMBEDDED IN THE CARBURETTOR BODY SUCH AS: FUEL SUPPLY PIPE, PLUNGER HOUSING, STARTER NOZZLE, PIT COVER FOR PROGRESSIONS AND INLET NOZZLE, MINIMUM AND MAXIMUM AIR GAUGE, THROTTLE VALVE CONTROL SHAFT. DO NOT REMOVE THROTTLE-SHAFT CONNECTION SCREWS. THE FIXING SCREWS ARE CAULKED AFTER ASSEMBLY AND THEIR REMOVAL DAMAGES THE SHAFT.

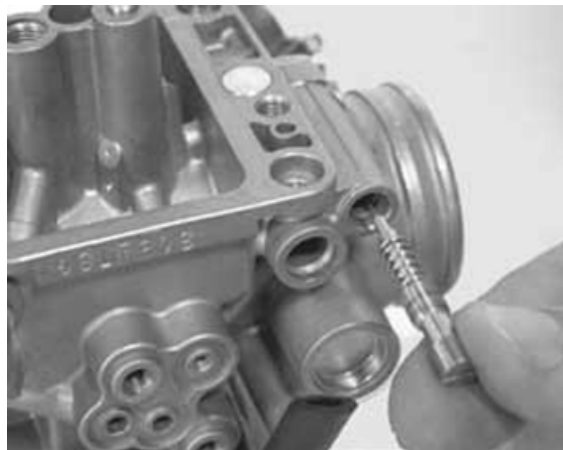

Walbro

To detach the carburettor from the engine, it is necessary to move the air filter and remove the transmission throttle control, the automatic starter connexion, the clamps anchoring the carburettor to the filter housing and to the inlet manifold, the air delivery pipe to the diaphragm, and the intake fitting.

- Take out the carburettor and rotate it so as to remove the screw with the water joint and the pipes

N.B.

THIS OPERATION IS NECESSARY TO AVOID LOSING SPRAYER PARTS WHEN CLEANING THE CARBURETTOR BODY. IF THE SPRAYER IS FORCED IN ITS HOUSING DO NOT ATTEMPT TO REMOVE IT AS THIS WILL ONLY DAMAGE IT.



Remove the protection, the bracket and the starter acting on the screw shown in the figure.

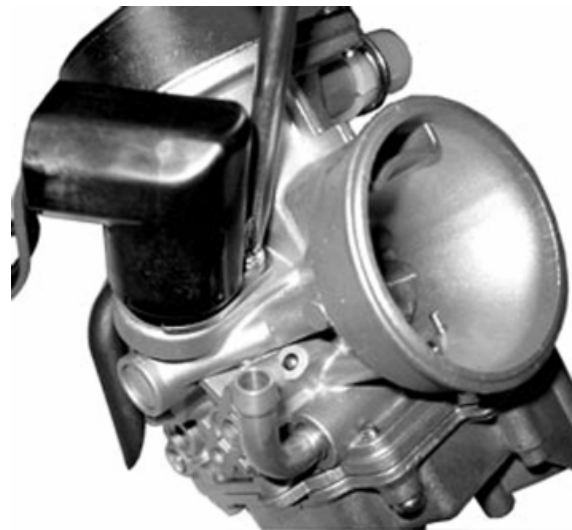

Remove the clamp and cover with the airing filter of the diaphragm chamber.



Remove the 4 fixing screws indicated in the figure and the vacuum chamber cover.

N.B.

DURING THE REMOVAL OF THE COVER TAKE SPECIAL CARE NOT TO RELEASE THE SPRING ACCIDENTALLY.

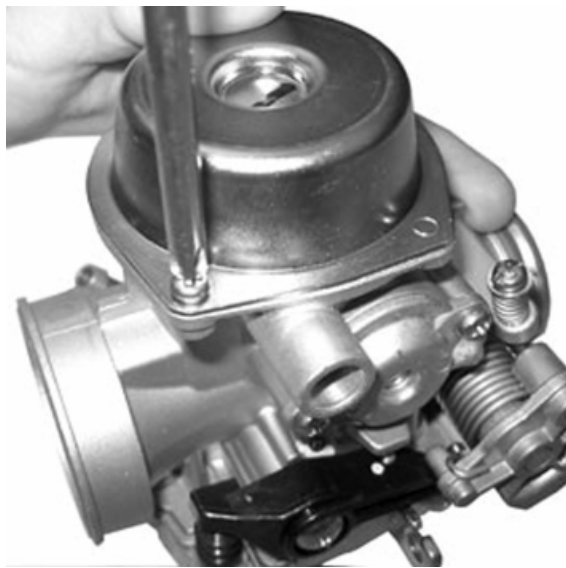

Remove the vacuum valve together with the diaphragm.



Unscrew the bayonet joint 1/8 of a turn, remove it, take out the spring and vacuum valve plunger

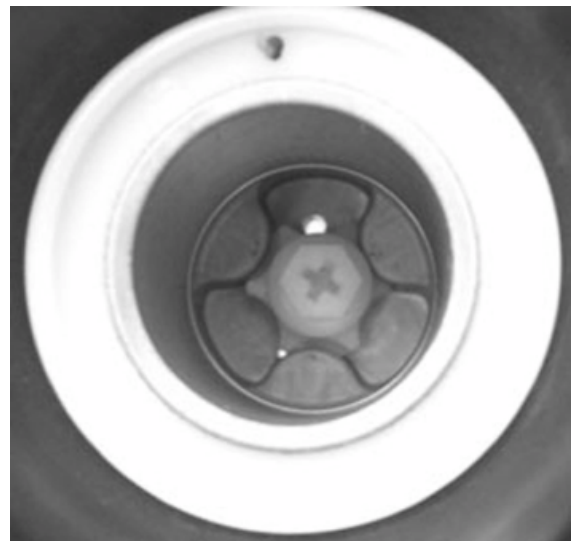

Remove the 4 screws shown in the figure.



Remove the tank with the intake pump, its control and gasket.



Remove the acceleration pump piston with the ring nut, the hood, the O-Ring and the spring from the tank as shown in the figure.

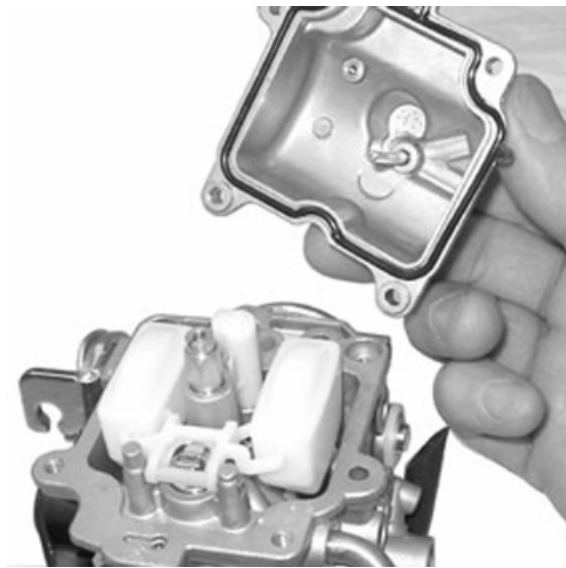

Adequately support the carburettor and using a rod and hammer remove the float pin acting from the throttle control side.

Remove the float and the plunger.



Remove the cover of the duct from the carburettor to the starter nozzle as shown in the figure.

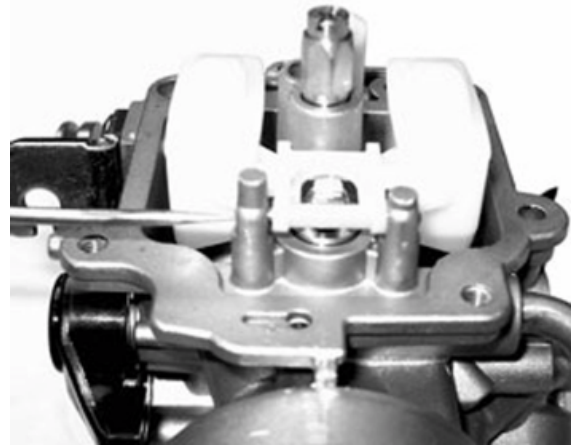

- Remove the maximum nozzle.
- Remove diffuser.

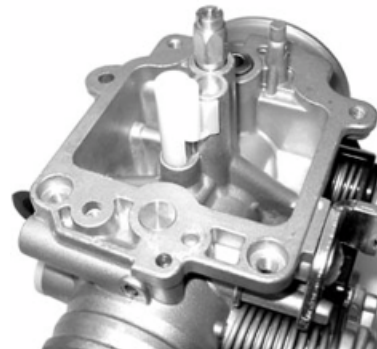

Remove the sprayer.

N.B.

THIS OPERATION IS NECESSARY TO AVOID LOSING SPRAYER PARTS WHEN CLEANING THE CARBURETTOR BODY. IF THE SPRAYER IS FORCED IN ITS HOUSING DO NOT ATTEMPT TO REMOVE IT AS THIS WILL ONLY DAMAGE IT.

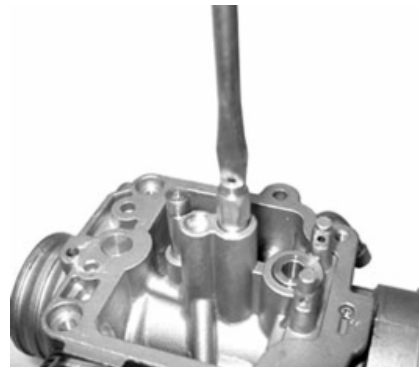

- Remove the minimum nozzle.

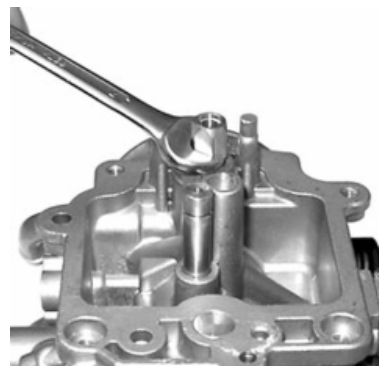

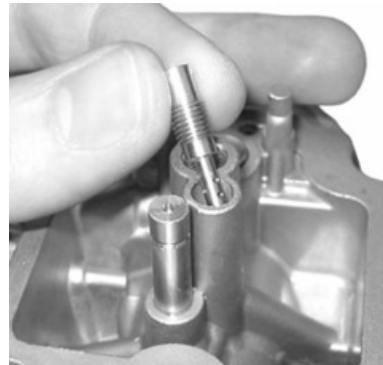
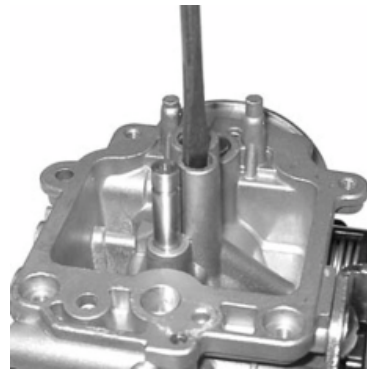

Remove the minimum flow screw with the O-ring, the washer and the spring.

-Remove the 2 fixing screws, the cover, the spring, and the cut-off device diaphragm.

CAUTION

DO NOT ATTEMPT REMOVING PARTS EMBEDDED IN THE CARBURETTOR BODY SUCH AS: FUEL SUPPLY PIPE, PLUNGER HOUSING, STARTER NOZZLE, PIT COVER FOR PROGRESSIONS AND INLET NOZZLE, MINIMUM AND MAXIMUM AIR GAUGE, THROTTLE VALVE CONTROL SHAFT. DO NOT REMOVE THROTTLE-SHAFT CONNECTION SCREWS. THE FIXING SCREWS ARE CAULKED AFTER THE ASSEMBLY AND THEIR REMOVAL DAMAGES THE SHAFT.



Refitting the carburettor

Kehin

- Before refitting, wash the carburettor body accurately with petrol and compressed air.
- Pay special attention to the fuel supply pipe and the plunger seat.



- For maximum circuit, check the air adjustment is correct as shown in the figure.

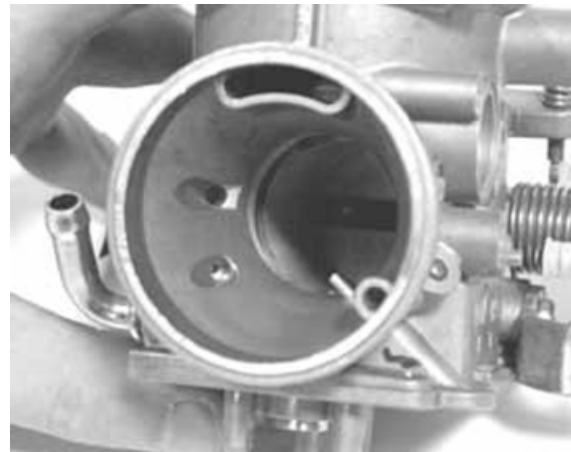

- For the minimum circuit, make sure the following points are properly cleaned: air gauging, outlet section controlled by flow screw, progression holes near the throttle valve.



- For the starter circuit, blow the connection pipe properly with the jet. This is necessary because the nozzle support hides other inaccessible internal calibrations.
- Blow the intake nozzle properly.

N.B.

THE ACCELERATION NOZZLE OUTLET IS EXTREMELY SMALL AND IS ORIENTED TO THE THROTTLE VALVE. NOZZLE INCORRECT ORIENTATION RESULTS IN INADEQUATE SPRAYING.

- Check that there are 5 closing ball joints for the operating pipes on the carburettor body.

- Check that the coupling surfaces, the tank and the diaphragm are not dented.
- Check that the depression valve housing pipe is not scratched.
- Check that the throttle valve and the shaft do not show abnormal wear.
- Check that the plunger seat does not show abnormal wear.
- Replace the carburettor in case of irregularities.
- Check that the return spring of the accelerating pump rocking lever is not deformed by over-stretching.

N.B.

TO AVOID DAMAGES, DO NOT INTRODUCE METAL OBJECTS IN THE ADJUSTED SECTIONS.

- Wash and blow the minimum nozzle properly and reassemble it.



- Properly wash and blow the components of the sprayer maximum circuit, the diffuser and the nozzle.
- Introduce the sprayer in the carburettor body with the shortest cylindrical part directed to the diffuser.
- Assemble the diffuser making sure the sprayer is being adequately inserted and lock it.
- Assemble the maximum nozzle.



- Check that the tapered pin does not show signs of wear on the sealing surfaces of the shock absorber pin and the return clamp.
- Replace the rod if worn out.



- Check that the float is not worn on the pin housing or on the contact plate with the plunger and that there are no fuel infiltration.
- Replace it in case of anomalies.

- Introduce the float with the rod on the fuel feeding tube side.

N.B.

INTRODUCE THE RETURN SPRING ON THE FLOAT PLATE ADEQUATELY

- Remove the drainage screw from the tank, wash and blow it properly and make sure the acceleration pump pipes are clean.

- Operate the acceleration pump piston repeatedly and blow with compressed air.

- Reassemble the acceleration pump valves following this order:

INTAKE VALVE (A)

- Spring
- Ball
- Nozzle

IN VALVE (M)

- Ball
- Spring
- Nozzle

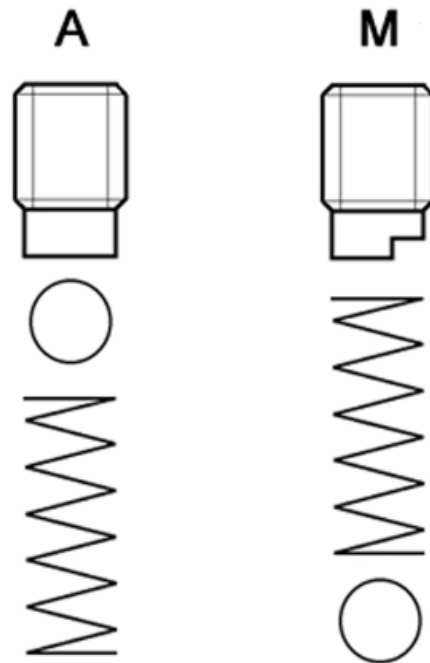

N.B.

THE IN VALVE NOZZLE, CORRESPONDING TO THE ACCELERATION PUMP, IS MILLED.

-Check the screw tightness introducing a small amount of fuel in the tank.

- Assemble a new gasket on the tank.

- Assemble the tank on the carburettor body fastening the 4 screws.

- Check that the control roller is free to rotate in its own seat.

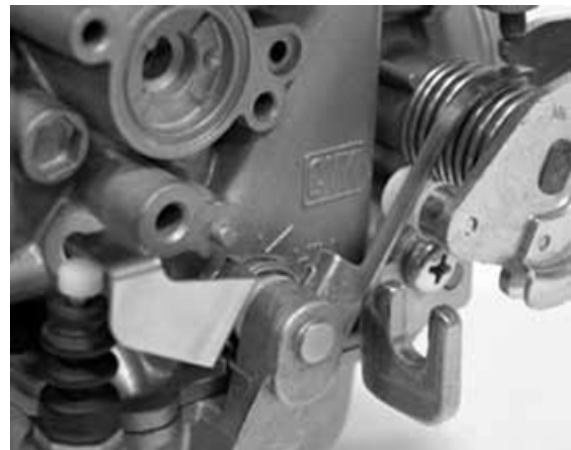

N.B.

MAKE SURE THE TANK GASKET IS CORRECTLY INTRODUCED

N.B.

AVOID DEFORMING THE ACCELERATION PUMP CONTROL ROCKING LEVER.

- Wash and blow the flow screw properly.
- Check that screw is not deformed and/or rusty.
- Assemble the spring on the screw.
- Screw the flow screw on the carburettor body.



- The screw final position should be determined by an exhaust fume analysis.
- Adjust the carburettor by turning the screw twice from the close position.

Walbro

- Before refitting, wash the carburettor body accurately with petrol and compressed air.
- Pay special attention to the fuel supply pipe and the plunger seat.

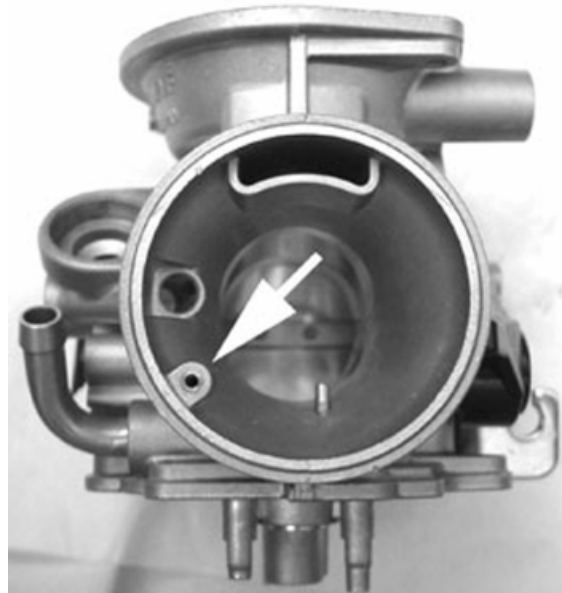

- For maximum circuit, check the air adjustment is correct as shown in the figure.
- Carefully clean the air holes indicated in the figure.



- For the minimum circuit, make sure the following points are properly cleaned: air gauging, outlet section controlled by flow screw, progression holes near the throttle valve.

N.B.

THE MINIMUM AIR IS CONTROLLED BY TWO ADJUSTMENTS. THE CUT-OFF ONE IS INDICATED DIRECTLY IN THE CARBURETTOR BODY.

- For the starter circuit, blow the connection pipe properly with the jet. This is necessary because the nozzle support hides other inaccessible internal calibrations.

- Blow the intake nozzle properly.

N.B.

THE ACCELERATION NOZZLE OUTLET IS EXTREMELY SMALL AND IS ORIENTED TO THE THROTTLE VALVE. NOZZLE INCORRECT ORIENTATION RESULTS IN INADEQUATE SPRAYING.



- Check that there are 5 closing ball joints for the operating pipes on the carburettor body.
- Check that the coupling surfaces, the tank and the diaphragm are not dented.
- Check that the depression valve housing pipe is not scratched.
- Check that the throttle valve and the shaft do not show abnormal wear.
- Check that the plunger seat does not show abnormal wear.
- Replace the carburettor in case of irregularities.

N.B.

TO AVOID DAMAGES, DO NOT INTRODUCE METAL OBJECTS IN THE ADJUSTED SECTIONS.

- Wash and blow the minimum nozzle properly and reassemble it.

- Properly wash and blow the components of the sprayer maximum circuit, the diffuser and the nozzle.

- Introduce the sprayer in the carburettor body with the shortest cylindric part directed to the diffuser.

- Assemble the diffuser making sure the sprayer is being adequately inserted and lock it.

- Assemble the maximum nozzle.

- Check that the tapered pin does not show signs of wear on the sealing surfaces of the shock absorber pin and the return clamp.

- Replace the rod if worn out.

- Check that the float is not worn on the pin housing or on the contact plate with the plunger and that there are no fuel infiltration.

- Replace it in case of anomalies.

- Assemble the float with the plunger introducing the pin on the carburettor feeding tube side.

N.B.

INTRODUCE THE RETURN SPRING ON THE FLOAT PLATE ADEQUATELY



Level check

Kehin

- Place the carburettor inclined as shown in the figure.



- Check that the float reference is parallel to the tank coupling surface
 - If different positions are detected, change the plunger control metal plate direction to obtain the position described above.
-

Walbro

- Make sure the float coupling surface is parallel to the tank surface with the carburettor in inverted position.
- If different positions are detected, change the plunger control metal plate direction to obtain the position described above.
- If the plate gets deformed, make sure it remains parallel to the float pin.

N.B.

WITH INVERTED CARBURETTOR, THE FLOAT WEIGHT SHOULD NOT EXCEED THE TAPERED PIN SPRING THRUST. OTHERWISE, CHECK THAT THE FLOAT IS NOT HEAVY DUE TO FUEL INFILTRATION. REPLACE THE FLOAT AND THE TAPERED PIN, IF NECESSARY.

- Wash and blow the carburettor duct cover properly and introduce it in the starter nozzle.

N.B.

INCORRECT ASSEMBLY OF CARBURETTOR DUCT COVER ON THE STARTER NOZZLE CAUSES A NEGATIVE COLD START-UP SITUATION: THE STARTER NOZZLE TAKES UP THE OLD FUEL FROM THE BOTTOM OF THE TANK.

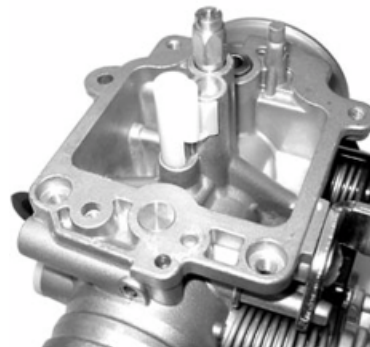

- Remove the drainage screw from the tank, wash and blow the tank properly and make sure the acceleration pump intake and supply valve are clean.
- Being the valves unidirectional, blow them carefully with compressed air, at the inner side of the tank for the intake valve and at the pump piston housing for the supply valve.
- Check that there are no signs of wear in the acceleration pump piston and its corresponding seat in the tank.
- In case of wear, replace the defective parts.
- Check that the acceleration pump piston contrast spring is not worn.
- Assemble a new O-Ring and a new bellows gasket. Reassemble the piston unit on the tank.
- Assemble a new O-Ring on the tank drainage screw and lock it.



- Check the screw tightness introducing a small amount of fuel in the tank.
- Assemble a new gasket on the tank.
- Assemble the tank on the carburetor body fastening the 4 screws.



- Wash and blow the flow screw properly and assemble a new O-Ring.
- Preassemble the components on the screw as follows: spring, washer and O-ring.
- Screw the flow screw on the carburetor body.
- The screw final position should be determined by an exhaust fumes analysis.



- Prepare the carburettor for adjustment by rotating the screw 3 turns from the close position.

- Check that the rocking lever control of the accelerating pump does not show abnormal wear.

- Check that the end of stroke screw of the rocking lever protrudes 3.2 mm.



Check that the return spring of the rocking lever is not loaded.

- Preassemble the spring and rocking lever as shown in the figure.

- Assemble the rocking lever on the carburettor keeping the throttle valve open.

- Lock the fixing screw of the rocking lever.

- Make sure that the mechanism works correctly.



Inspecting the valve and needle

Kehin

- Check that the tapered pin of the vacuum valve does not show wear.

- Check that the depression valve does not show threads on the external surfaces.

- Check that the vacuum intake hole is not clogged.

- Check that the diaphragm is not damaged or has hardened, otherwise replacement the whole valve.

- Insert the tapered pin into the vacuum valve housing.

- Reassemble the vacuum valve on the carburettor body taking care that the tapered pin is inserted into the sprayer.



N.B.

THE VALVE CAN BE INSERTED IN ONLY ONE POSSIBLE POSITION.



- Reassemble the spring with the pin lock.
- Remove the cover of the vacuum chamber being careful to correctly insert the spring in its place on the cover.
- Tighten the screws.



- Wash and blow dry the filter sponge of the ambient pressure intake.



-
- Reassemble the filter with its clamp.



-
- Wash and blow dry the starter support.
Assemble a new gasket on the carburettor body and tighten the 2 fixing screws.



Walbro

-
- Check that the pin does not show signs of wear and that the lock is in the 3rd of the 3 notches.
 - Check that the valve does not show threads around its external diameter.
 - Check that the 2 vacuum supply holes are not clogged.

N.B.

THE 2 VACUUM SUPPLY HOLES ARE OF DIFFERENT DIAMETERS.



-
- Check that the diaphragm is not worn or has hardened.

If it does, replace it.

- Refit the tapered pin on the vacuum valve.
- Make sure the spring is in the correct position on the plunger and inserted in its housing.
- Assemble the coupling by rotating it 1/8 of a turn.



-
- Reassemble the vacuum gas valve on the carburetor body being careful that the tapered pin is inserted into the sprayer.

- Time the vacuum valve rotation inserting the diaphragm tab in its place.

When the diaphragm is correctly assembled to the valve, the main vacuum supply hole is positioned axially with the diffuser, on the throttle valve side.

- Refit the spring on the valve.
 - Refit the vacuum chamber cover matching the reference mark with the orientation of the diaphragm.
 - Tighten the screws to the prescribed torque.
 - Check the cut-off valve correct functioning.
- Check that the diaphragm is not worn or has hardened. Check the free length of the spring.

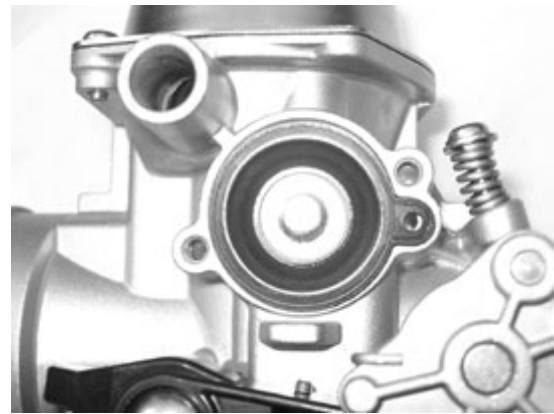

Characteristic

Walbro: Standard length of cut-off spring

24 mm

- Reassemble the diaphragm and the metal pin placed on the valve.
- Reassemble the spring and the cover. The vacuum intake should be facing upwards.

Inspecting the automatic choke device

- Check that the piston of the automatic starter is not deformed or rusty.
- Check that the piston slides freely from the seat to the support.
- Check that the sealing gasket of the piston is not deformed.
- The starter must be more or less functional depending on the ambient temperature.
- Measure the protrusion of the piston as shown in the figure and check the corresponding value.
- Make sure that the starter is adjusted for the ambient temperature.
- The starter should disconnect progressively by means of electrical heating.
- Check the starter resistance when adjusted to the ambient temperature.

With a 12V battery power the automatic starter and check that piston protrudes as much as possible.

- The correct warm up time depends on the ambient temperature.
- If protrusion, resistance or timing values are different from the ones prescribed, replace the starter.
- Assemble the starter to the carburettor being careful to position the O-Ring correctly, insert the plate with the machined side contacting the starter, tighten the 2 fixing screws.
- Position the starter as shown in the figure.
- Assemble the protection casing.

Characteristic

Check the auto starter: Protrusion Value for Walbro

12.5 ÷ 13 mm at approx. 20°C

Check the automatic starter: maximum protrusion

18.5 ÷ 19 mm

Check the automatic starter: Max. time:

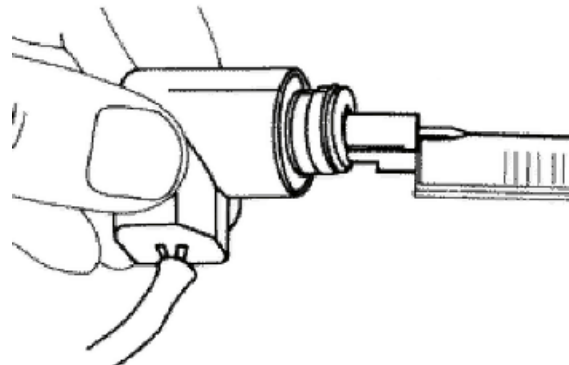
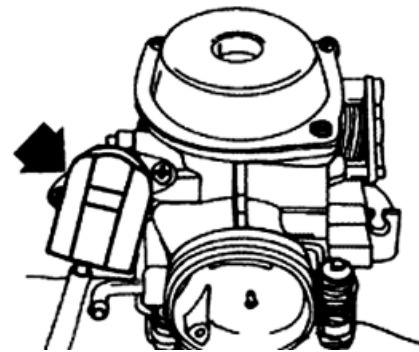

5 min

Electric characteristic

Check the automatic starter: Resistance

around 30 Ω

Kehin

- Check that the automatic starter piston is not deformed or rusty.
- Check that the piston slides freely from the seat to the support.
- Check that the piston sealing gasket is not deformed.
- The starter must be more or less functional depending on the ambient temperature.
- Measure the protrusion of the piston as shown in the figure and check its corresponding value.
- Make sure that the starter is adjusted for the ambient temperature.
- The starter should disconnect progressively by means of electrical heating.
- Check the starter resistance when adjusted to the ambient temperature.

With a 12V battery power the automatic starter and check that the piston protrudes as much as possible.

- The correct warm up time depends on the ambient temperature.
- If protrusion, resistance or timing values are different from the ones prescribed, replace the starter.
- Assemble the starter to the carburettor being careful to position the O-Ring correctly, insert the plate with the machined side contacting the starter, tighten the fixing screws.
- Position the starter as shown in the figure.
- Assemble the protection casing.

N.B.

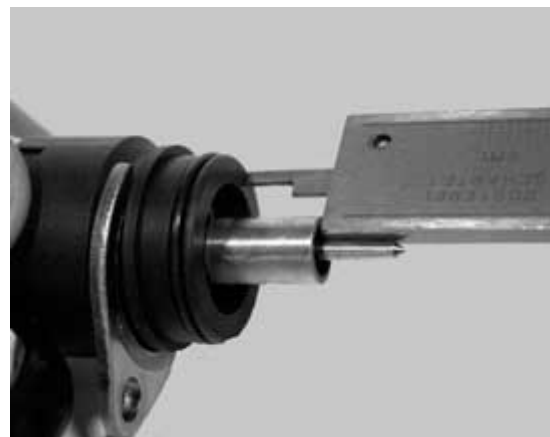

TO CARRY OUT THIS CHECK PAY SPECIAL ATTENTION NOT TO GENERATE SHORT CIRCUITS USE A CABLE SECTION WITH A TERMINAL SUITABLE TO BE CONNECTED TO THE STARTER.

Characteristic

Check the automatic starter: Kehin: Protrusion value

XX ÷ XX mm at approx. 20°C

Check the automatic starter: Kehin maximum protrusion

XXX ÷ XXX mm

Check the automatic starter: Keihin maximum time

5 min



Walbro

- Check that the automatic starter piston is not deformed or rusty.
- Check that the piston slides freely from the seat to the support.
- Check that the piston sealing gasket is not deformed.
- The starter must be more or less functional depending on the ambient temperature.
- Measure the protrusion of the piston as shown in the figure and check its corresponding value.
- Make sure that the starter is adjusted for the ambient temperature.
- The starter should disconnect progressively by means of electrical heating.
- Check the starter resistance when adjusted to the ambient temperature (20 - 25° C).

With a 12V battery power the automatic starter and check that the piston protrudes as much as possible.

- The correct warm up time depends on the ambient temperature.



- If protrusion, resistance or timing values are different from the ones prescribed, replace the starter.

Characteristic

Check the auto starter: Protrusion Value for Walbro

12.5 ÷ 13 mm at approx. 20°C

Check the automatic starter: Walbro maximum protrusion

18.5 ÷ 19 mm

Check the automatic starter: Walbro max. time

5 min

Electric characteristic

Walbro Resistance

approx. 40 Ω

INDEX OF TOPICS

SSUSPENSIONS

SUSP

Front

Removing the front wheel

- Remove the front calliper.
- Loosen the wheel axle lock-nut.



- Loosen the two wheel axle safety screws on the fork leg, on the brake calliper side.
- Pull out the wheel axle.



See also

[Removal](#)
[Removal](#)

Front wheel hub overhaul

Check that the wheel bearings do not show signs of wear.

If you have to replace the wheel bearings, proceed as follows:

- Remove the plastic cover on the tone wheel side to avoid damage by loosening the 5 fixing screws.
- Remove the two bearings on the odometer drive side using the pliers 14 or 34 and the bell detail 9.
- Remove the internal spacer.



* Either tool can be used.



- Support the front wheel with two wooden shims that make it possible to avoid scratching in the case of contact with the rim.

- Insert the punch (consisting of adaptor handle, 15 mm adaptor and guide) from the odometer drive side to permit the removal of the brake disc side bearing and the spacer bushing.



Specific tooling

020376Y Adaptor handle

020456Y Ø 24 mm adaptor

020412Y 15 mm guide

- Heat the bearing seat on the side the brake disc with the heat gun.



- Insert the bearing using the punch consisting of adaptor handle, 42x47 mm adaptor and 15 mm guide, and drive it up to the stop.



- Reinsert the spacer bushing on the brake disc side using the appropriate tool and take it to the stop.

Specific tooling

020376Y Adaptor handle

020359Y 42x47-mm adaptor

020412Y 15 mm guide

020201Y Spacer bushing driving tube



- Turn over the wheel and insert the internal spacer with the part fitted with the Seeger ring facing the bearing on the brake disc side installed previously.



- Heat the bearing seat on the odometer drive side with the heat gun.



- Insert the two bearings using the punch consisting of adaptor handle, 32x35 mm adaptor and 15 mm guide, and drive it up to the stop.

Specific tooling

020376Y Adaptor handle

020357Y 32 x 35 mm adaptor

020412Y 15 mm guide



- Refit the cap and tighten the five fixing screws.



Refitting the front wheel

- Grease the wheel axle, then install it from the tone wheel side and install the tone wheel properly.
- Tighten the wheel axle nut to the prescribed torque.



N.B.

**TAKE CARE NOT TO DAMAGE THE ODOMETER DRIVE.
FOR THE SAKE OF SAFETY, OFFSET THE INTERNAL STOP FROM THE STOP OF THE TONE WHEEL BY 90°.**

- Tighten the two safety screw on the leg to the prescribed torque.



Locking torques (N*m)

Front wheel axle nut 45 - 50 Safety screw on fork leg 6 ÷ 7

Handlebar

Removal

- Remove the rear handlebar cover.
- Remove the pin mounting the handlebar to the steering tube.
- Remove the handlebar and place it on the rear cover of the front shield.



See also

[Rear handlebar cover](#)

Refitting

- Install the handlebars on the steering tube, paying attention to the centring, aligning the recess on the handlebar with that on the steering tube as shown in the figure.
- Tighten the handlebar fixing screw on the steering tube to the prescribed torque.

Locking torques (N*m)

Handlebar fixing screw (*) 45 ÷ 50

(*) Lubricate the nuts with engine oil before installation



Front fork

Removal

- Remove the front wheel.
- Remove the handlebar.
- Using the appropriate tool, loosen and remove the upper ring nut, the distancing washer, the counter ring nut and the spacer ring.
- Extract the fork.

N.B.

TAKE CARE TO SUPPORT THE FORK SO AS TO PREVENT IT FROM COMING OFF ABRUPTLY

Specific tooling

020055Y Wrench for steering tube ring nut

See also

[Removal](#)

[Removing the front wheel](#)



Overhaul

- Check that the roller bearing does not show signs of wear or pricking.

In case of replacement, proceed as follows:

- Support the fork in a vice.
- Insert the contrast plate in the upper end of the steering tube

N.B.

ONLY REMOVE THE UPPER BALL BEARING IF YOU REALLY NEED TO.

- Insert the special tool as shown in the figure.



- Insert the retaining band of the two half-rings.



- Using a 19 mm hexagonal spanner, extract the roller bearing.

Specific tooling

020458Y Puller for lower bearing on steering tube



- Insert the a new plate and a new dust guard in the steering tube
- Insert a new roller bearing in the roller tube.
- Using the special tool and a mallet to move the dust guard and the bearing in abutment.

Specific tooling

006029Y Punch for fitting fifth wheel seat on steering tube



- With the 10 mm hexagonal wrench for internal parts loosen the upper stem closing cap.



-
- Loosen the stem support clamp and remove fork leg and stem.



-
- Remove the first spring consisting of 15 windings.
 - Remove the spring support plate.
 - Remove the second spring consisting of 21 windings.
 - Drain the oil.
 - Separate the stem from the leg by removing the screws with copper washer shown in the figure. To prevent the rotation of the pumping insert a 12 mm hexagonal wrench for internal parts in the stem.



-
- Remove the dust guard ring using a screwdriver as shown in the figure.



-
- Remove the oil guard safety lock using a screwdriver.
 - Using the appropriate special tool, remove the oil seal.
 - Insert the tie rod complete with cable into the oil guard.
 - Insert the two half rings for diameter 35 mm stems.



- Keeping the tie rod in vertical position, insert the bell for the Ø 35 mm stems.
- Insert the nut in the thread and take out the oil guard



Specific tooling

020487Y Fork oil seal extractor

- Check the length of the springs.

SPRING LENGTH CHECK

Specification	Desc./Quantity
Standard length	15 winding spring: 116.3 + 2-1 mm
Standard length	21 winding spring: 175.7 + 2-1 mm
Allowable limit after use:	15 winding spring: 114.3 mm
Allowable limit after use:	21 winding spring: 173.7 mm

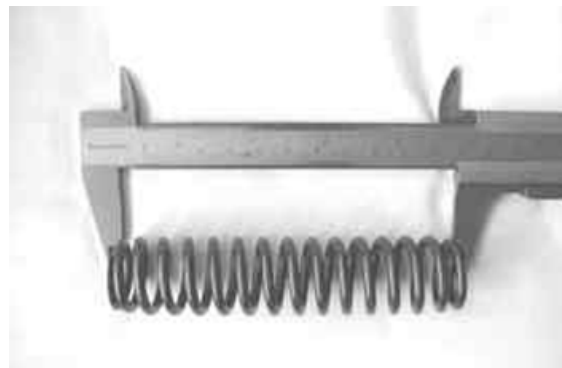

Check there are no signs of wear or seizing up between the stem and the leg. If there are, replace the damaged part.

Characteristic

Maximum leg diameter

35.10 mm

Minimum stem diameter

34.90 mm

Check that the oil holes on the pumping element are not clogged. - Check that the O-ring shows no sign of damage.



- Insert a new oil guard with the special adaptor handle and take it to the stop.
- Insert the safety clip.
- Insert a new dust guard.



- Insert the contrast spring into the pumping member.
- Insert the pumping element inside the stem.
- Insert the pumping element guide bushing at the lower stem end.
- Insert the stem in the leg being careful not to let the stem guide bushing come out.



- Inset and screw up the copper washer to the prescribed torque. To prevent the pumping member from rotating, insert a 12 mm Allen key into the stem.
- Pour $102 \pm 1 \text{ cm}^3$ of oil into the stem.



Recommended products

AGIP FORK 7.5 W Fork oil

Grade 7.5 W

- Insert the 21 winding springs, the support plate with the chamfer facing downwards and then the 15 winding spring.



- Insert the stem into the fork clamp.
- Do up the clamp once to allow the stem closure upper cap to be tightened.
- Check that the sealing ring on the cap is in good working order, then tighten the cap on the stem to the prescribed torque.



- Loosen the fork clamp screws and ensure the stem closure cap is fitted properly on the clamp.
- Tighten the clamp screws to the prescribed torque.



Specific tooling

020376Y Adaptor handle

020359Y 42x47-mm adaptor

Locking torques (N*m)

Fork clamp screws 20 ÷ 25 Stem upper cap 15 ÷ 30 Lower screw with copper washer 25 - 35

Refitting

- Grease using lithium soap grease on the roller bearings.

Recommended products

AGIP GREASE PV2 Grease for the steering bearings, pin seats and swinging arm

White anhydrous-calcium based grease to protect roller bearings; temperature range between -20 C and +120 C; NLGI 2; ISO-L-XBCIB2.



- Insert the fork into the headstock.
- Insert the spacer ring.
- Using an appropriate tool do up the first ring nut in the steering tube (upper steering ball bearing). Tighten to the prescribed torque.
- Install the space washer.
- Using the special tool, tighten the second locking ring nut in the steering tube to the prescribed torque.



Specific tooling

020055Y Wrench for steering tube ring nut

Locking torques (N*m)

Steering lower ring nut $10 \div 13$ then loosen by 90°
Upper steering ring nut $30 \div 36$

Steering bearing

Removal

- Remove the fork
- Check that the upper ball bearing and the seat of the lower roller bearings do not show signs of wear or pricking.

In case of replacement, proceed as follows:

- Using a punch to remove the bearings, insert it from the bottom and remove the ball bearing above the headstock. Then remove the lower seat of the roller bearing by inserting the punch from the top of the headstock.

N.B.

ONLY REMOVE THE UPPER BALL BEARING IF YOU REALLY NEED TO.

Specific tooling

020004Y Punch for removing fifth wheels from headstock

See also

[Removal](#)



Refitting

Using the appropriate tool, refit the upper ball bearing and the seat of the lower roller bearings on the headstock as described below:

- Place a new ball bearing on the headstock and a roller bearing seat on the lower part.
- Insert the tie rod screw of the appropriate tool fitted out with the adaptors for planting the bearing and seat it in the headstock as in the photograph.



- Using two 24 mm wrenches, tighten the screw until the seat and the bearing are fully set in place.

N.B.

ALWAYS USE A NEW BEARING AND A NEW SEAT.

Specific tooling

001330Y Tool for fitting steering seats

Rear

Removing the rear wheel

- Remove the muffler support bracket
- Remove the 5 screws shown in the photograph



Refitting the rear wheel

- Carry out the removal operations but in reverse order, observing the prescribed tightening torques.

Locking torques (N*m)

Fixing screw for wheel rim to hub 34 ÷ 38

Swing-arm

Removal

- Place the scooter on its centre stand;
- Support the engine adequately;
- Loosen the nut shown in the figure and pull out the spindle from the left-hand side.



- Loosen the nut and lock nut on the left-hand side of the scooter (see figure) and unscrew the spindle from the opposite side.
- Remove the retaining screw of the rear brake pipe shown in the figure.



- Loosen the nut on the inside of the frame from the left-hand side (see figure) and remove the relevant spindle;
- Remove the swinging arm.



Overhaul

- Check that the silent bloc is not damaged. If there is, replace it.
- Remove the Seeger ring shown in the photograph

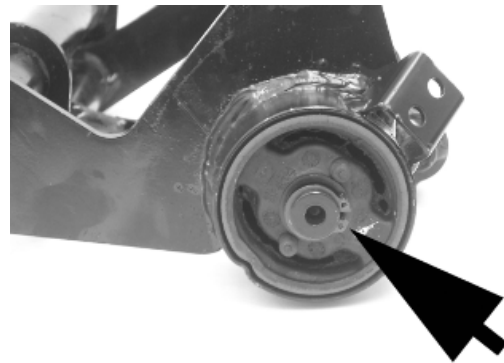

- Remove the full silent bloc bracket
- Hold the full silent bloc bracket in the clamp
- Using the appropriate tool, remove the silent bloc from the bracket from the side corresponding to the inside of the vehicle. This is to guarantee the tool is centred properly on the support

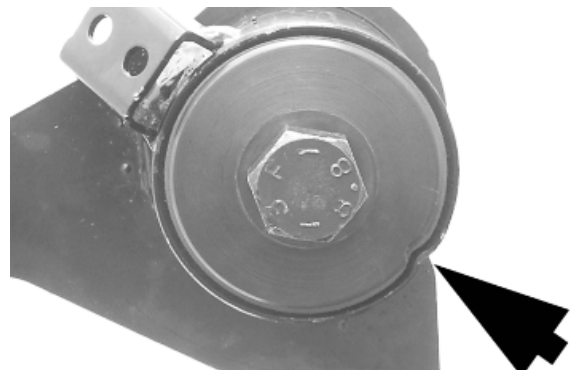

Specific tooling

020271Y Tool for removing-fitting silent bloc



- Install a new silent bloc, making sure it aligns properly with the reference tooth.
- Fit the silent blocs, making sure the chamfered part of the silent bloc matches the chamfered part of the bracket

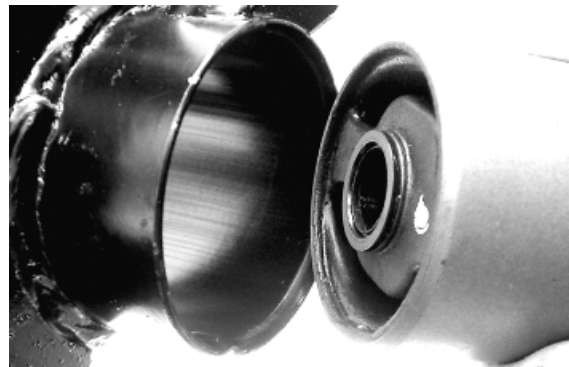

- Using the appropriate tool, fit the silent bloc as shown in the photo

Specific tooling

020271Y Tool for removing-fitting silent bloc



- Check there is no sticking in the movement of the connection of the swinging arm on the engine side to the swinging arm on the frame side.
- Check the axial clearance between the two swinging arms using a feeler gauge

Characteristic

Allowable limit after use:

1 mm

standard clearance

0.40 ÷ 0.70 mm



- In order to check the clearance of the swinging arm on the frame side, prepare a retainer using the fixing pin of the swinging arm on the frame and two rings from the special tool 020229Y.

Alternatively, use two washers with inside diameter of 12 mm for pins, outside diameter min. 30 mm and thickness min. 4 mm.

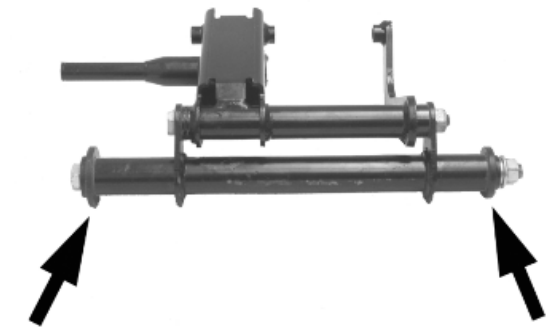

- Separate the swinging arm on the engine side from the vehicle side arm.

- Remove the internal spacer shown in the photograph

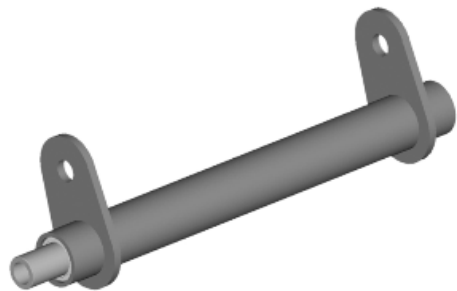

- Using a suitable pin remove the roller casings as shown in the photographs



- Using an appropriate tool plant new roller casings, being careful to position the bearings with the O-rings facing outwards

Specific tooling

020115Y Ø 18 punch

020244Y 15 mm diameter punch



SWINGING ARM SERVICE

Specification	Desc./Quantity
Length of the internal swinging arm spacer on the frame side	228 -0.2/-0.4 mm
Length of the internal swinging arm spacer on the engine side	183 0/-0.2 mm
Length of the swinging arm tube on the engine side	182.5 -0.1/-0.3 mm
Length of the swinging arm tube on the frame side	227.1 +0.2/0 mm

- Lubricate the roller bearing housings with grease
- Insert the spacers
- Assemble the two arms with the relative bolt in the position shown in the photograph
- Adjust the bolt as shown in the photograph
- Position the frame side swinging arm with the most protruding part pointing towards the silent block side as shown in the photograph



Recommended products

AGIP GREASE PV2 Grease for control levers on the engine

White anhydrous-calcium based grease to protect roller bearings; temperature range between -20 °

C and +120 °C; NLGI 2; ISO-L-XBCIB2

Refitting

For correct installation of the swinging arm on the scooter, proceed as follows:

1. Position the silent block supporting clamp with part **3** inserted, and slightly tighten part **1**
2. Position the swinging arm, inserting part **2**
3. Tighten part **3** to the prescribed torque
4. Screw on and tighten part **4** to the prescribed torque
5. Screw on and tighten part **5** to the prescribed torque
6. Tighten part **1** to the prescribed torque

Insert the swinging arm - engine bolt and tighten to the prescribed torque

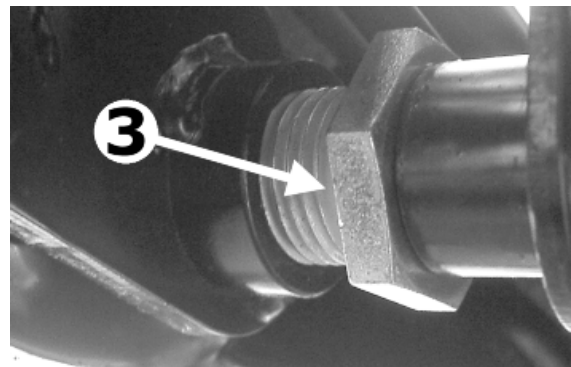
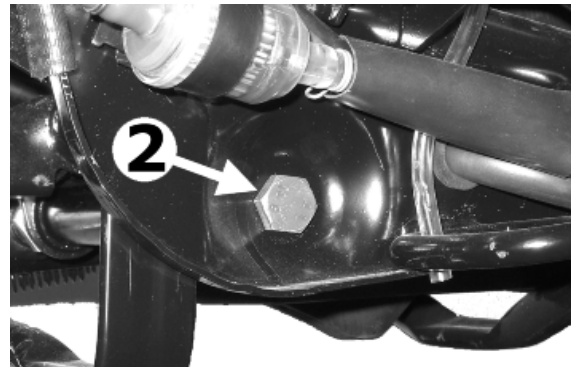
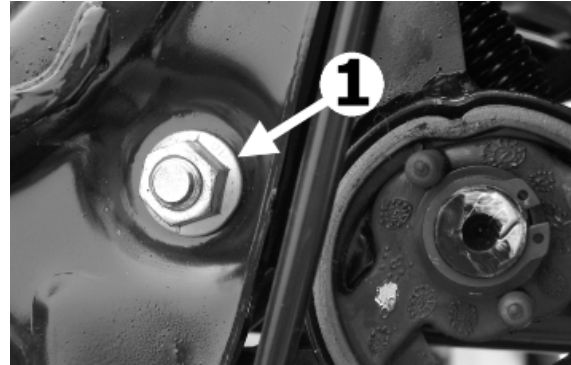

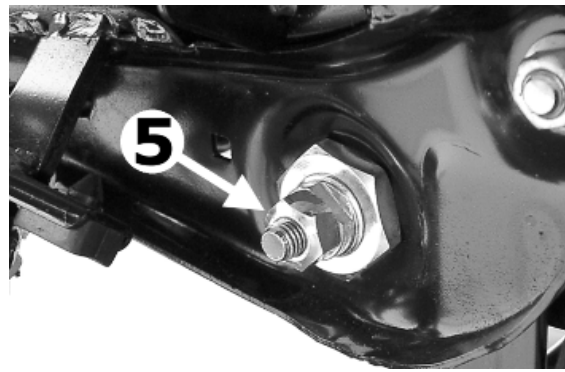
**SWINGING ARM FITTING**

Name	Torque in Nm
Part 1	64 ÷ 72 Nm
Part 3	5 - 7 Nm
Part 4	90 ÷ 110 Nm
Part 5	64 ÷ 72 Nm
Engine-swinging arm bolt	64 - 72

Shock absorbers**Removal**

Proceed as follows:

- place the scooter on its centre stand;
- lift the engine a little with a jack so as to free the two shock absorbers;
- remove the muffler
- undo the shock absorber spring assembly clamping screw from the support fixed to the engine on the one side and from that fixed to the muffler on the other;
- unscrew the two upper nuts (one on each side) fixing the shock absorber spring assembly to the frame and remove the shock absorbers.

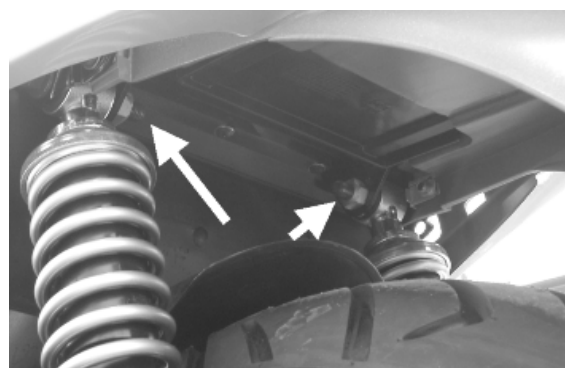
**See also**

[Exhaust assy. Removal](#)

Refitting

Carry out the previous operations but in reverse order.

Locking torques (N*m)

Shock absorber lower clamp 33 ÷ 41 Upper shock absorber clamp 33 ÷ 41

Exhaust bracket

Removal

- Loosen and remove the lower retaining bolt of the right-hand shock absorber at the support arm.
- Loosen the 2 retaining screws between arm and engine.
- Remove the split pin and safety cover; unscrew the wheel axle nut; use the rear brake to prevent the wheel from turning.
- Remove the support arm.



Remove the full muffler assembly.

See also

[Exhaust assy. Removal](#)

[Exhaust assy. Removal](#)

Overhaul

- Remove the circlip shown in the photograph

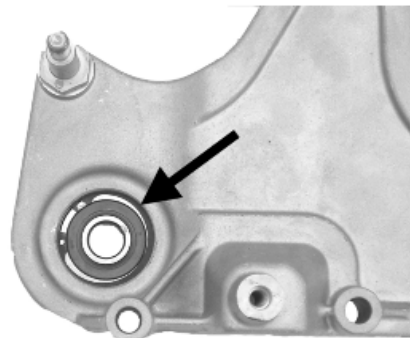

- Support the muffler support bracket sufficiently
- Using the special punch, remove the bearing from its seat as shown in the photograph

Specific tooling

020376Y Adaptor handle

020456Y Ø 24 mm adaptor

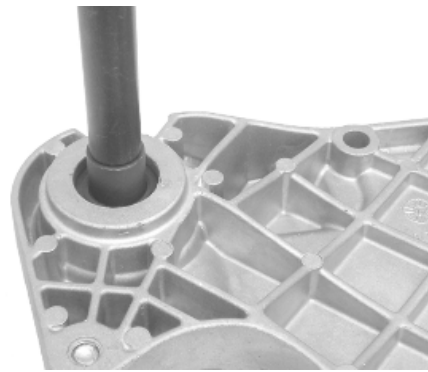

- Heat the bearing seat using the heat gun
- Using the special punch, install a new bearing in the seat as shown in the photograph

Specific tooling

020376Y Adaptor handle

020151Y Air heater

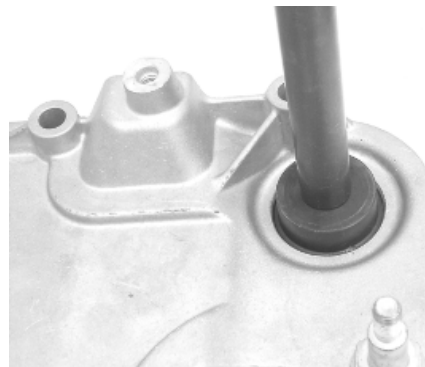

Refitting

To refit, carry out the removal operations in reverse order, observing the prescribed tightening torques.

Locking torques (N*m)

Rear wheel axle nut 104 ÷ 126 Muffler support arm to engine screws (*) 20 ÷ 25 Shock absorber lower clamp 33 ÷ 41

Centre-stand

- Remove the two return springs from the centre stand.
- Undo the nut shown in the figure.
- Remove the bolt from the right side.
- Remove the centre stand.
- On refitting tighten the nut to the prescribed torque.

Locking torques (N*m)

Centre stand bolt 25 ÷ 30



Removal

- Unhook the springs.
- Loosen the nut.
- Pull out the screw.

Reassembly

- Install the sealing rings on the support tube of the stand;
- Carry out the operations described above in reverse order, then insert the sealing rings into their seats.

CAUTION

Lubricate the following parts with grease: spring coupling pins, bushings on stand fixing bracket.

Recommended products

AGIP GREASE PV2 Grease for control levers on the engine

White anhydrous-calcium based grease to protect roller bearings; temperature range between -20 ° C and +120 °C; NLGI 2; ISO-L-XBCIB2

Locking torques (N*m)

stand retaining bolt 20 ÷ 25

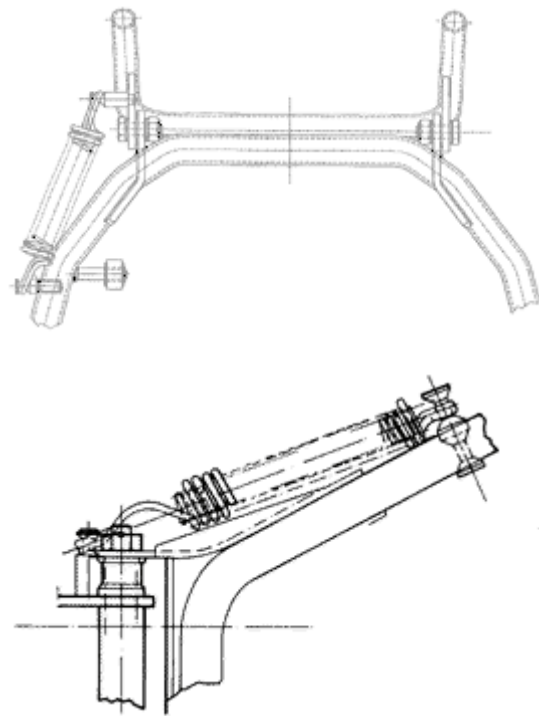

Side stand

Removal of the side stand

- Unhook the springs;
- Loosen the nut;
- Pull out the screw;

Fitting

Carry out the previous operations in reverse order.

Locking torques (N*m)

Side stand fixing bolt 35 ÷ 40



INDEX OF TOPICS

BRAKING SYSTEM

BRAK SYS

Interventions rules

WARNING

THE FLUID FOR THE BRAKE SYSTEM IS CORROSIVE: ALWAYS WEAR PROTECTIVE GLOVES. IN THE EVENT OF ACCIDENTAL CONTACT WITH THE EYES, RINSE THE CONTACT AREA WELL WITH COPIOUS AMOUNTS OF WATER.

THE BRAKE FLUID DRAINED FROM THE SYSTEM IS HARMFUL TO THE ENVIRONMENT. COLLECTION AND DISPOSAL MUST BE CARRIED OUT IN COMPLIANCE WITH THE REGULATIONS IN FORCE. UNDER NORMAL DRIVING AND CLIMATIC CONDITIONS YOU SHOULD CHANGE THE FLUID EVERY TWO YEARS. IF THE BRAKES ARE USED INTENSELY AND/OR IN HARSH CONDITIONS, CHANGE THE FLUID MORE FREQUENTLY.

DURING INSTALLATION, THE PARTS TO BE REUSED MUST BE ABSOLUTELY CLEAN AND FREE FROM ANY TRACES OF OIL, FUEL AND GREASE: IT IS THEREFORE NECESSARY TO CARRY OUT THOROUGH CLEANING WITH PURE ALCOHOL.

N.B.

FOR TOPPING UP AND REPLACEMENT, USE ONLY BRAKE FLUID DOT4 - NHTSA 116. OBSERVE THE MAXIMUM DEGREE OF CLEANLINESS. THE HYDRAULIC FLUID IS EXTREMELY CORROSIVE FOR PAINTED SURFACES.

BRAKE FLUID IS HYGROSCOPIC; IT TENDS TO ABSORB MOISTURE FROM THE SURROUNDING AIR.

IF THE MOISTURE CONTENT IN THE BRAKE FLUID EXCEEDS A CERTAIN VALUE, IT WILL RESULT IN REDUCED BRAKING EFFICIENCY AND A REDUCTION IN THE BOILING POINT OF THE FLUID.

N.B.

ALWAYS STORE THE FLUID IN SEALED CONTAINERS.

N.B.

RUBBER PARTS SHOULD NEVER BE LEFT IN ALCOHOL FOR LONGER THAN 20 SECONDS. AFTER WASHING, THE PIECES MUST BE DRIED WITH A BLAST OF COMPRESSED AIR AND A CLEAN CLOTH.

THE SEAL RINGS MUST BE IMMERSSED IN THE OPERATING LIQUID; THE USE OF THE PRF1 PROTECTION IS TOLERATED.

WARNING

THE PRESENCE OF BRAKE FLUID ON THE DISC OR BRAKE PADS REDUCES THE BRAKING EFFICIENCY. IN THIS CASE, REPLACE THE PADS AND CLEAN THE DISC WITH A HIGH-QUALITY SOLVENT.

Rear brake calliper

Removal

- Inspect the condition of the hoses, packing and joint. In the event of fluid leaks from the calliper, this must be replaced.
- Detach the oil brake pipe from the calliper; pour the fluid inside a container.
- Remove the clamps shown in the figure.

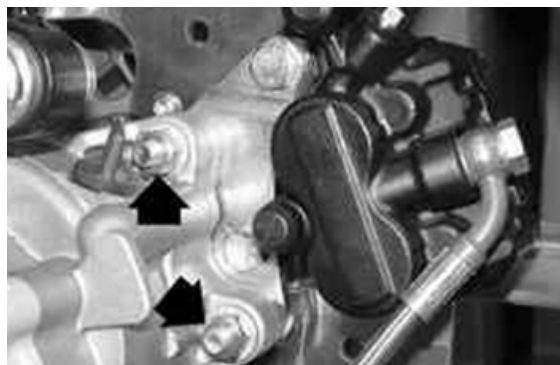

Refitting

- Fix the brake calliper support plate to the crank-case and the brake calliper to the bracket, tightening the screws to the prescribed torque.
- Apply the recommended product to the fixing screws of the brake calliper to the bracket.
- Bleed the system.

N.B.

WHILE REFITTING, REPLACE THE COPPER GASKETS ON THEIR FITTINGS.

Recommended products

Loctite 243 Medium-strength threadlock

Loctite 243 medium-strength threadlock

Locking torques (N*m)

Oil bleed screw 12 - 16 Screw tightening calliper to the support 23 ÷ 25 Screw fixing rear brake calliper support to engine 20 ÷ 25 Brake fluid pipe-calliper fitting 16 ÷ 20

See also

[Rear - combined](#)

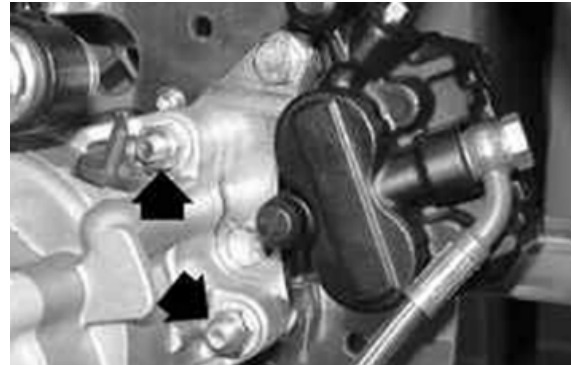

Front brake calliper

Removal

- Inspect the condition of the hoses, packing and joint. In the event of fluid leaks from the calliper, this must be replaced.
- Detach the oil brake pipe from the calliper; pour the fluid inside a container.
- Remove the clamps shown in the figure.



Overhaul

Proceed as follows:

- 1) remove the two male hexagonal screws (1) and take out the two pads (10);
- 2) remove the two male hexagonal screws (2) and remove the reaction plate (3);
- 3) take out the fixed plate (4) from the guide;
- 4) remove the internal elements from the floating body (5) with the help of short blows of compressed air through the brake fluid pipe in order to facilitate the expulsion of pistons (6).

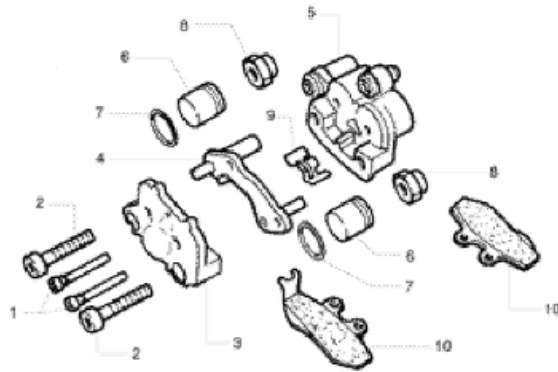

5) Check:

- that the plates and the body are whole and in good condition;
- that the cylinder and the floating body of the calliper do not show signs of scratches or erosion, otherwise replace the entire calliper;
- that the guides of the fixed plate are not scratched or eroded, otherwise replace the entire plate;
- that the brake pad check spring works properly.

Refitting

- 1) insert the pistons (6) and the sealing rings (7) in the body;
- 2) place the guide rubbers (8) and refit the fixed plate (4);
- 3) assemble the reaction plate (3) tightening the screws (2), insert the brake pad check spring (9) and then the pads, fixing them with the corresponding screws (1);
- 5) place the calliper on the disc and lock it to the strut by tightening the fixing screws;
- 6) fix the pipe joint on the calliper at the prescribed torque.

Functioning

This is a floating type calliper.

It takes advantage of the action and reaction principle to obtain the thrust for both pads.

The body and the reaction plate body work integrally and can move axially with respect of the fixed plate that is integral to the strut.

The pistons, forced by pressure to push the pad to the disk, cause the reaction plate to push in turn the other pad towards the disc.

The brake pad lock spring

1. Pad fixing screws
2. Reaction plate fixing screws
3. Reaction plate
4. Fixed plate
5. Floating body
6. Piston
7. Piston sealing rings
8. Guide protection rubbers
9. Brake pad check spring
10. Pads

CAUTION

ALL THE SEALS AND GASKETS MUST BE REPLACED EVERY TIME THE CALLIPER IS SERVICED.

Locking torques (N*m)

Brake fluid pipe-calliper fitting 20 ÷ 25 Pad fastening pin 19.6 ÷ 24.5

Refitting

- When refitting, tighten the nuts to the prescribed torque.
- Bleed the system.

N.B.

WHILE REFITTING, REPLACE THE COPPER GASKETS ON THEIR FITTINGS.

Locking torques (N*m)

Oil bleed screw 12 - 16 Screw tightening caliper to the support 20 ÷ 25 Brake fluid pipe-calliper fitting 16 ÷ 20

See also

[Front](#)



Rear brake disc

Removal

- Remove the rear wheel.
- Remove the hub and the brake disc.
- Carry out the same procedure with the front brake disc.



See also

[Removing the rear wheel](#)

Refitting

- For the installation, position the disc correctly using the arrow stamped on it as reference.
- Tighten the screws to the prescribed torque and apply the recommended product.

N.B.

THE SURFACE OF THE DISC WITH THE STAMPED ARROW FOR THE DIRECTION OF ROTATION MUST FACE TOWARDS THE OUTSIDE OF THE SCOOTER.

Recommended products

Loctite 243 Medium-strength threadlock

Loctite 243 medium-strength threadlock

Locking torques (N*m)

Brake disc fixing screws 11 ÷ 13

Disc Inspection

Checking the disc is important; it must be perfectly clean, with no sign of rust, oil or grease or other dirt and must not show signs of deep scoring.

Characteristic

New rear disc thickness

4.0 mm

Disc thickness at wear limit (rear)

3.5 mm



- Remove the wheel and check using the appropriate tools that the axial run-out of the brake surface is within the prescribed limits.
- If this is not the case, replace the disc and repeat the test.

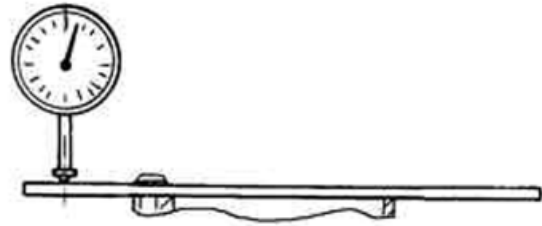

WHEN INSTALLING, THOROUGHLY CLEAN THE DISC AND ITS SEAT ON THE HUB.

Characteristic

Max. axial run-out

0.1 mm

Front brake disc

Removal

Proceed as follows:

- Remove the front wheel.
- Loosen the five disc fixing screws.
- Thoroughly clean the seats on the front wheel hub and on the disc.



See also

[Removing the front wheel](#)

Refitting

For the fitting, position the disc correctly using the arrow stamped on it as reference.

- Do up the screws to the prescribed torque and apply the recommended product

N.B.

THE ARROW STAMPED ON THE DISC INDICATING THE RUNNING DIRECTION MUST BE FITTED TOWARDS THE OUTSIDE OF THE VEHICLE.

Recommended products

Loctite 243 Medium-strength threadlock

Loctite 243 medium-strength threadlock

Locking torques (N*m)

Brake disc fixing screw 5 ÷ 6.5

Disc Inspection

Checking the disc is important; it must be perfectly clean, with no sign of rust, oil or grease or other dirt and must not show signs of deep scoring.

Characteristic

Thickness of a new front disc

4.0 mm

Disc thickness at wear limit (front)

3.5 mm



- Remove the wheel and check using the appropriate tools that the axial run-out of the brake surface is within the prescribed limits.
- If this is not the case, replace the disc and repeat the test.

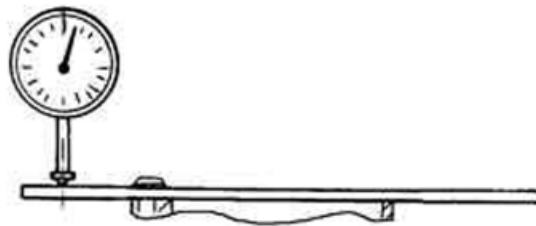

WHEN INSTALLING, THOROUGHLY CLEAN THE DISC AND ITS SEAT ON THE HUB.

Characteristic

Max. axial run-out

0.1 mm

Front brake pads

Removal

Proceed as follows:

- Remove the front calliper.
- Loosen the two pins shown in the figure that lock the two pads.
- Remove the pads, being careful of the pads' spring clamp.
- Check the thickness of the pads.



Characteristic

Minimum value

1.5 mm

See also

[Front brake calliper](#)

Refitting

To fit, proceed as follows:

- Insert the two pads in the callipers.
- Screw the two pad lock pins to the correct torque, and apply the recommended product.
- Fit the calliper on its support, tightening the two screws to the prescribed torque.

N.B.

IF IT IS NOT POSSIBLE TO CORRECTLY POSITION THE CALLIPER ON THE DISC DURING FITTING, GENTLY EXPAND THE PADS.

Recommended products

Loctite 243 Medium-strength threadlock

Loctite 243 medium-strength threadlock

Locking torques (N*m)

Screw tightening calliper to the support 20 ÷ 25 Pad fastening pin 19.6 ÷ 24.5

Rear brake pads

Removal

Proceed as follows:

- Remove the rear brake calliper
- Remove the two pins holding the brake pads.
- Remove the pads, paying attention to the pad retaining spring.
- Check the thickness of the pads.

If the thickness is less than the minimum value, replace the pads with new pads.



Characteristic

Minimum value

1.5 mm

See also

[Removal](#)

Refitting

Carry out the installation by analogy with the procedure described for the installation of the rear brake calliper.

- Tighten the two calliper fixing screws to the prescribed tightening torque.

Locking torques (N*m)

Pad fastening pin 19.6 ÷ 24.5 Screw tightening calliper to the support 20 ÷ 25 Fixing screws for the calliper support on the engine 20 ÷ 25

Fill

Rear - combined

Proceed as follows:

- Position the vehicle on a flat surface and on the stand
- Loosen the two screws shown in the figure and open the front brake fluid reservoir.
- Through the bleed screw on the brake calliper, bleed the system using a hose of adequate diameter.
- Collect the used fluid in a container.
- Pump on the brake lever to completely drain the system of all used fluid.
- Tighten the bleed valve.
- Refill the brake system tank up to the maximum level with the prescribed fluid.
- Attach the tube of the special tool to the bleed fitting.
- Actuate the tool at the bleed fitting, at the same time constantly topping up the brake system tank to prevent air being drawn into the system, until no more air escapes at the bleed fitting. The operation is finished when only brake fluid comes out of the bleed screw.
- Close the bleed screw and tighten to the prescribed torque.
- Close the brake system tank.



N.B.

IF AIR CONTINUES TO COME OUT DURING THE BLEED OPERATION, EXAMINE ALL THE FITTINGS. IF SAID FITTINGS DO NOT SHOW SIGNS OF BEING FAULTY, LOOK FOR THE AIR INPUT AMONG THE VARIOUS SEALS ON THE PUMP AND CALLIPER PISTONS. WHEN CARRYING OUT THE OPERATION, BRAKE FLUID MAY LEAK FROM THE BLEED SCREW ON THE CALLIPER AND ON THE DISC. IN THIS

CASE; CAREFULLY CLEAN THE CALLIPER AND DEGREASE THE BRAKE DISC.

Specific tooling

020329Y MityVac vacuum-operated pump

Locking torques (N*m)

Oil bleed screw 12 - 16

Front

Proceed as follows:

- Position the vehicle on a flat surface and on the stand
- Loosen the two screws shown in the figure and open the front brake fluid reservoir.
- Through the bleed screw on the brake calliper, bleed the system using a hose of adequate diameter.
- Collect the used fluid in a container.
- Pump on the brake lever to completely drain the system of all used fluid.
- Tighten the bleed valve.
- Refill the brake system tank up to the maximum level with the prescribed fluid.
- Attach the tube of the special tool to the bleed fitting.
- Actuate the tool at the bleed fitting, at the same time constantly topping up the brake system tank to prevent air being drawn into the system, until no more air escapes at the bleed fitting. The operation is finished when only brake fluid comes out of the bleed screw.
- Close the bleed screw and tighten to the prescribed torque.
- Close the brake system tank.



N.B.

IF AIR CONTINUES TO COME OUT DURING THE BLEED OPERATION, EXAMINE ALL THE FITTINGS. IF SAID FITTINGS DO NOT SHOW SIGNS OF BEING FAULTY, LOOK FOR THE AIR INPUT AMONG THE VARIOUS SEALS ON THE PUMP AND CALLIPER PISTONS. WHEN

CARRYING OUT THE OPERATION, BRAKE FLUID MAY LEAK FROM THE BLEED SCREW ON THE CALLIPER AND ON THE DISC. IN THIS CASE; CAREFULLY CLEAN THE CALLIPER AND DEGREASE THE BRAKE DISC.

Specific tooling

020329Y MityVac vacuum-operated pump

Locking torques (N*m)

Oil bleed screw 12 - 16

Front brake pump

Removal

- Remove the rear handlebar cover.
- Drain the brake system.
- Disconnect the brake fluid line from the pump, paying attention to a possible escape of remaining brake fluid.
- Remove the front and rear brake stop button from the lever.
- Loosen the two retaining screws of the stand and remove together with the rear view mirror.
- Remove the front brake pump together with the lever.

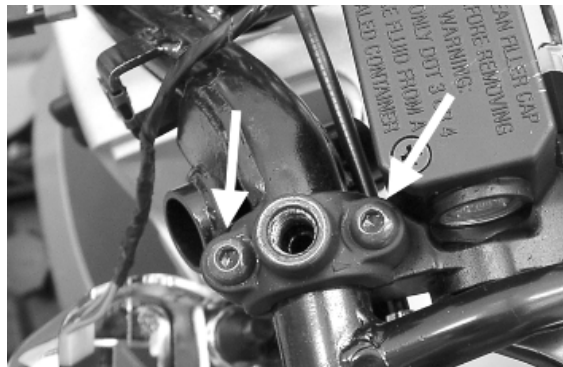

See also

[Front](#)

[Rear handlebar cover](#)

Overhaul

- 1) Remove the brake lever by loosening the fixing screw; open the cover (2) and take out the diaphragm (3);
- 2) Remove the cap and unscrew the internal parts in the specified order;
- 3) Check that:
 - The body of the pump shows no signs of internal damage or corrosion;
 - The piston shows no sign of damage or abnormal wear;
 - The piston return spring is in good condition.

Refitting

Reinstall the individual parts in the reverse order to the removal, paying attention to the correct positioning of the rubber parts in order to ensure leak tightness.

1. Tank cover screw
2. Tank cover
3. Diaphragm
4. Bellows
5. Seal ring
6. Piston
7. Gasket
8. Spring
9. Tank

CAUTION

ALL THE SEALS AND GASKETS MUST BE REPLACED EVERY TIME THE PUMP IS SERVICED.

Refitting

- Upon refitting, perform the operation but in reverse order.
- Tighten the hydraulic line to the prescribed torque and purge the system.
- When the operation is over, tighten the brake fluid bleed screw to the prescribed torque.

WARNING

THE BRAKE FLUID IS HYGROSCOPIC, THAT IS, IT ABSORBS MOISTURE FROM THE SURROUNDING AIR. IF THE LEVEL OF MOISTURE IN THE FLUID EXCEEDS A GIVEN VALUE, BRAKING EFFICIENCY WILL BE REDUCED. THEREFORE, ALWAYS USE FLUID FROM SEALED CONTAINERS. UNDER NORMAL DRIVING AND CLIMATIC CONDITIONS YOU SHOULD CHANGE THIS LIQUID EVERY TWO YEARS. IF THE BRAKES ARE USED INTENSELY AND/OR IN HARSH CONDITIONS, CHANGE THE FLUID MORE FREQUENTLY.

CAUTION

WHEN CARRYING OUT THE OPERATION, BRAKE FLUID MAY LEAK FROM BETWEEN THE BLEED SCREW AND ITS SEAT ON THE CALLIPER. CAREFULLY DRY THE CALLIPER AND DE-GREASE THE DISC SHOULD THERE BE BRAKE FLUID ON IT.

Locking torques (N*m)

Oil bleed screw 12 - 16 Hydraulic line fixing screw: 16 ÷ 20 Fixing screws for handlebar control assembly U-bolts 7 ÷ 10

See also

[Front](#)

Rear brake pump - combined

Removal

- Remove the rear handlebar cover.
- Drain the brake system.
- Disconnect the brake fluid line from the pump, paying attention to a possible escape of remaining brake fluid.
- Remove the front and rear brake stop button from the lever.
- Loosen the two retaining screws of the stand and remove together with the rear view mirror.
- Remove the front brake pump together with the lever.

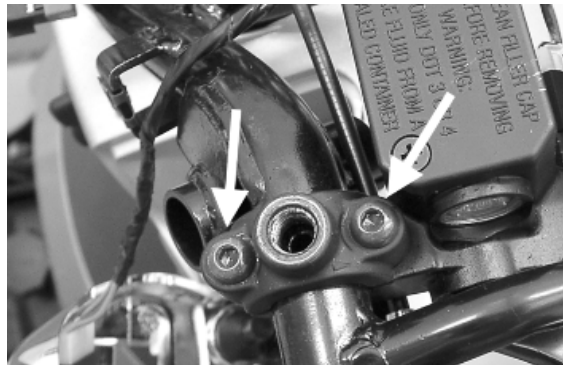

See also

- [Rear - combined](#)
- [Rear handlebar cover](#)

Refitting

- Upon refitting, perform the operation but in reverse order.
- Tighten the hydraulic line to the prescribed torque and purge the system.
- When the operation is over, tighten the brake fluid bleed screw to the prescribed torque.

WARNING

THE BRAKE FLUID IS HYGROSCOPIC, THAT IS, IT ABSORBS MOISTURE FROM THE SURROUNDING AIR. IF THE LEVEL OF MOISTURE IN THE FLUID EXCEEDS A GIVEN VALUE, BRAKING EFFICIENCY WILL BE REDUCED. THEREFORE, ALWAYS USE FLUID FROM SEALED CONTAINERS. UNDER NORMAL DRIVING AND CLIMATIC CONDITIONS YOU SHOULD CHANGE THIS LIQUID EVERY TWO YEARS. IF THE BRAKES ARE USED INTENSELY AND/OR IN HARSH CONDITIONS, CHANGE THE FLUID MORE FREQUENTLY.

CAUTION

WHEN CARRYING OUT THE OPERATION, BRAKE FLUID MAY LEAK FROM BETWEEN THE BLEED SCREW AND ITS SEAT ON THE CALLIPER. CAREFULLY DRY THE CALLIPER AND DEGREASE THE DISC SHOULD THERE BE BRAKE FLUID ON IT.

Locking torques (N*m)

Oil bleed screw 12 - 16 Hydraulic line fixing screw: 16 ÷ 20 Fixing screws for handlebar control assembly U-bolts 7 ÷ 10

See also

- [Front](#)

INDEX OF TOPICS

COOLING SYSTEM

COOL SYS

Circuit diagram

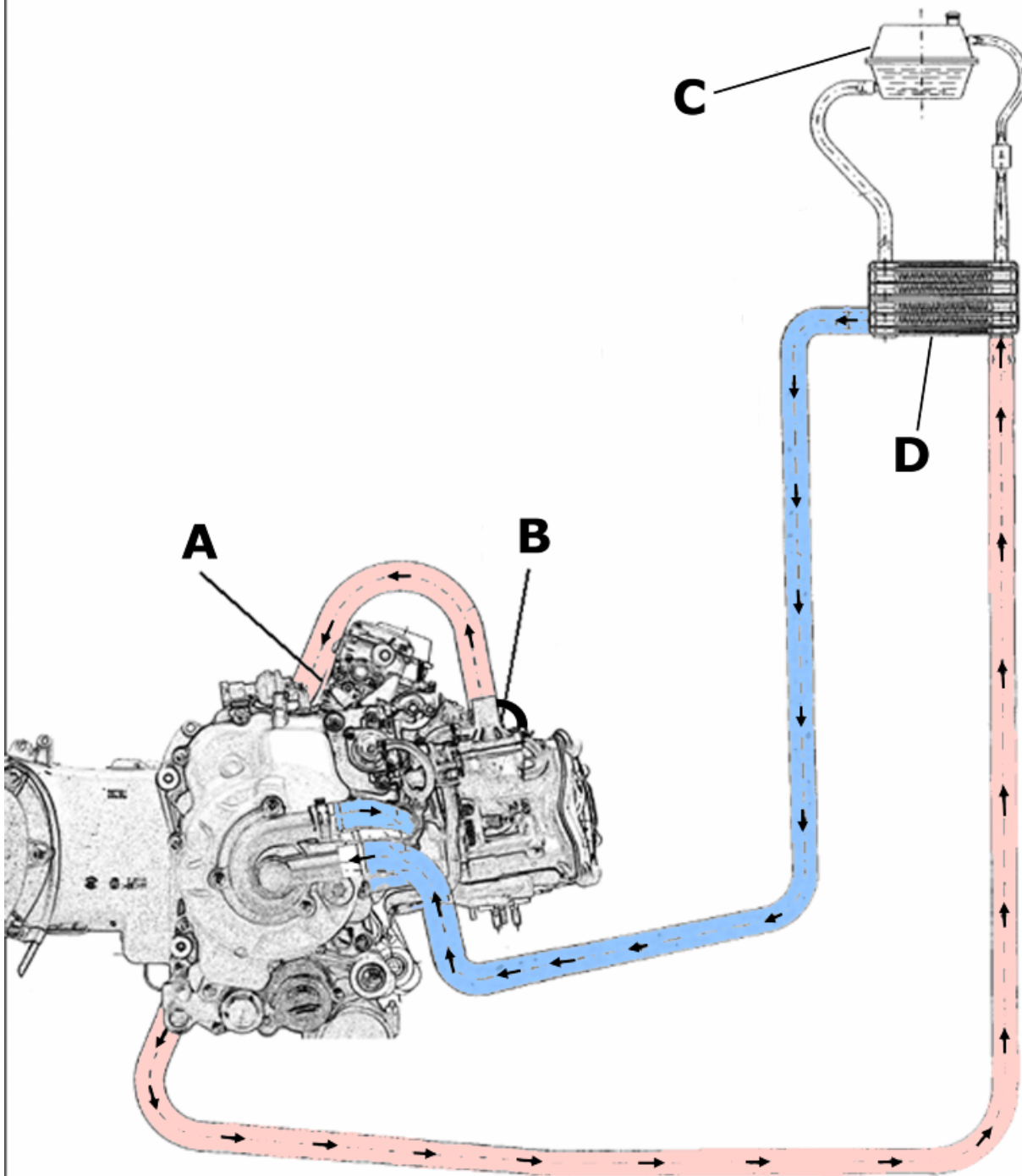

COOLING CIRCUIT

Specification	Desc./Quantity
A	Carburettor heating circuit
B	Thermostat with by-pass
C	Expansion tank
D	Radiator

Water pump - overhaul

- Remove the complete flywheel cover
- Remove the stator
- Remove the pump cover by loosening the 3 fixing screws
- Remove the sealing gasket

The pump can be serviced using the special tool and a press. The special tool is designed to be used with the presses most commonly found in workshops. For those presses equipped with a 35-mm piston and protective cap with fixing screw, it is sufficient to remove the cap and install the components of the special tool in its place. The special tool can be prepared in advance depending on its use on presses equipped with piston with a threaded type of coaxial coupling tang or cylindrical with stop groove. Then prepare the threaded ring with the adapter suitable for the coupling of the press used.

- Position the flywheel cover in the hydraulic press by inserting the impeller in the ring that is part of the special tool, as shown in the photo

N.B.

POSITION THE BASE WITH THE SURFACE PROVIDED WITH BETTER FINISH TURNED TOWARDS THE FLYWHEEL COVER. FAILURE TO COMPLY WITH THIS INSTRUCTION MAY RESULT IN DETERIORATION OF THE SURFACE INTENDED FOR THE COOLANT'S SEAL.

Specific tooling

020628Y Water pump service kit

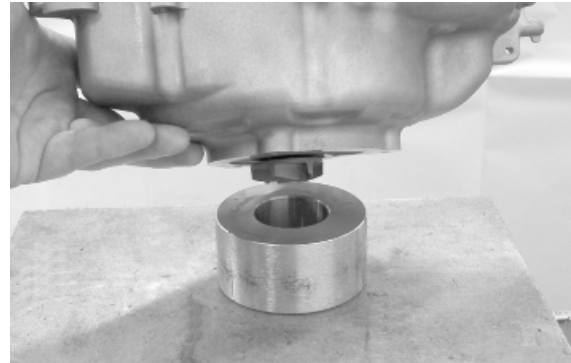

Install the pin that is part of the special tool on the press piston.

Turn the flywheel cover until it permits insertion of the pin inside the joint and eject the pump shaft from the joint and bearings.

Specific tooling

020628Y Water pump service kit

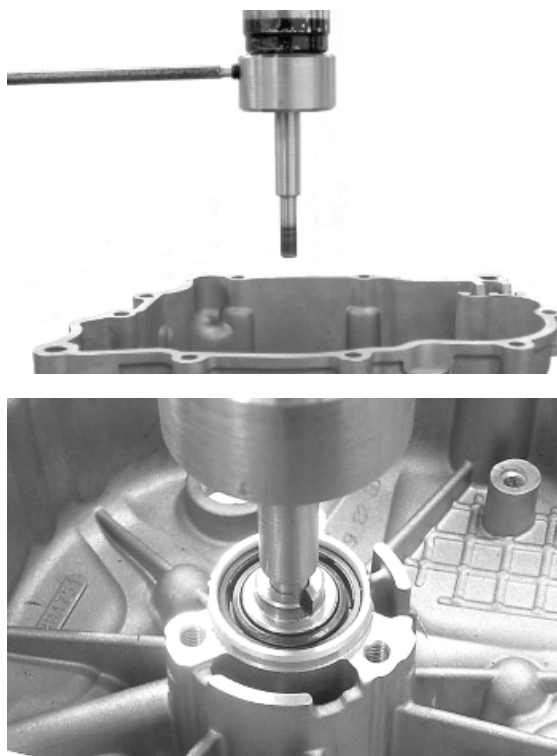

Remove the ceramic seal from the pump shaft. Using a screwdriver, remove the ceramic ring and sealing gasket from the flywheel cover.

N.B.

IN THE EVENT YOU PLAN TO REUSE THE MECHANICAL SEAL, PAY ATTENTION DURING THE DISASSEMBLY STAGES IN ORDER TO NOT CHIP THE CERAMIC RING.



- Remove the joint from the seat inside the seal ring.
- Position the flywheel cover in the press while sustaining it using the surface to be used for coupling with the engine case.

CAUTION

CHECK THE POSITIONING OF THE CENTRING DOWELS. PROPERLY PROTECT THE COUPLING SURFACE.

Centre the cover until it permits insertion of the pin and then eject the seal ring and the two ball bearings.

Specific tooling**020628Y Water pump service kit**

Before you reassemble, wash all the components and continue with the following checks.

Flywheel cover: Check that there are no cracks or oxidation on the seat of the ceramic seal. Check the capacity loads of the bearings and of the seal ring. Check the efficiency of the drain hole.



Shaft: Check to be sure there is no oxidation.
 Check that the impeller is in perfect condition.
 Ceramic seal: Check that the ceramic seals are not worn, cracked or scored. Check that the two rubber seals are in perfect condition. Check the thrust spring.
 Bearings: Check that they do not have irregular plays or are noisy.



Entrainment joint: Check that there is no abnormal wear on the seat for the oil seal seat and on the slots for the entrainment spring.



Heat the flywheel cover using the heat gun

N.B.

IF THE JOB IS PERFORMED WITH THE STATOR MOUNTED, HEAT FROM THE EXTERNAL SIDE OF THE COVER.

Specific tooling

020151Y Air heater

020150Y Air heater support



Properly support the cover and using the modular punch, install the two bearings all the way down at the same time.

N.B.

WORK IN AN UPRIGHT POSITION

Specific tooling

020376Y Adaptor handle

020441Y 26 x 28 mm adaptor

020629y 8 mm guide



Let the flywheel cover guard cool down and then manually mount the static part of the ceramic seal with the relative rubber seal.

N.B.

PAY ATTENTION TO MOUNTING THE CERAMIC RING CORRECTLY. THE CHAMFER ON THE INTERNAL DIAMETER MUST BE TURNED AWAY FROM THE SIDE OF THE BEARINGS.

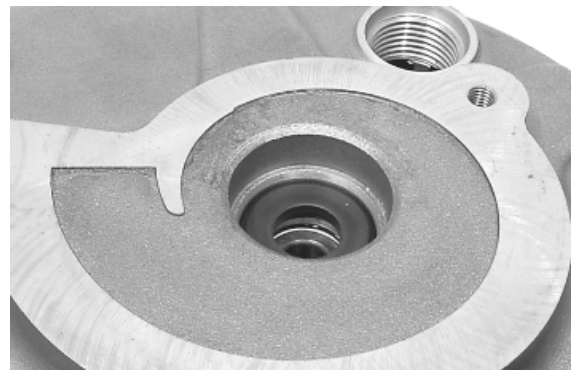

Mount the moving part of the ceramic seal on the shaft with the impeller. The rubber part must rest against the impeller.



Position the flywheel cover on the press using the support base for the bearings that is part of the special tool. Install the special punch with the impeller's template on the press piston.

Specific tooling

020628Y Water pump service kit

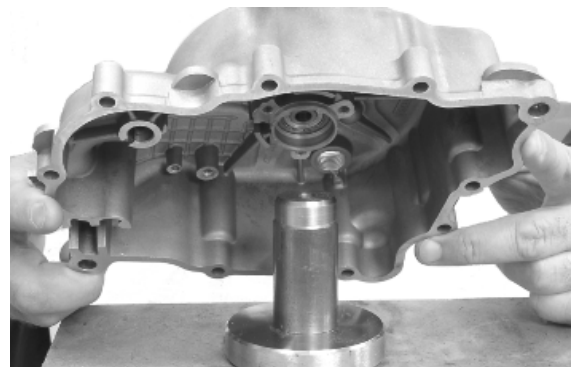

Manually insert the pump shaft in the relative bearings.



While keeping the bearings in contact with the support base, line up the shaft with the press piston and proceed with the driving. The driving depth is determined by the beat of the punch when it is in contact with the flywheel cover.

N.B.

SO AS TO NOT DAMAGE THE FLYWHEEL COVER DURING THE DRIVING OPERATION, SLIGHTLY TURN IT BY HAND IN ORDER TO BETTER PERCEIVE THE MOMENT OF CONTACT WITH THE PUNCH.

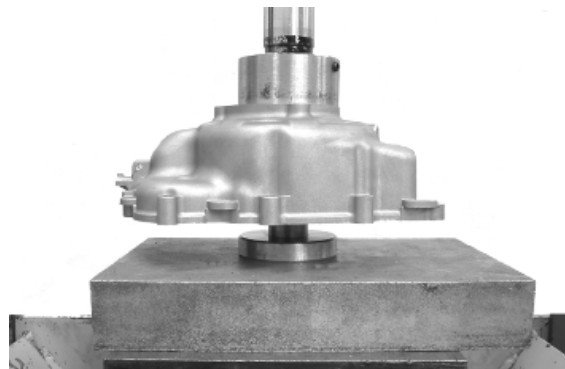

Specific tooling

020628Y Water pump service kit

Remove the special punch from the press piston and support the flywheel cover from the impeller side with it.

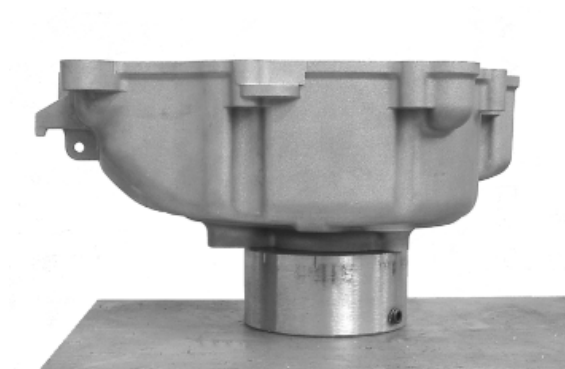

Put the new oil seal on the special punch while being careful to position the seal lip starting from the side of the handle.

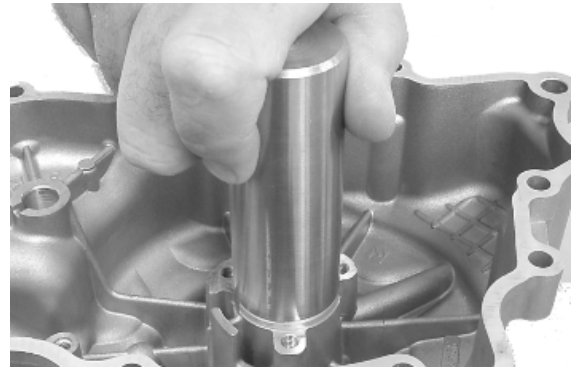

Install the oil seal on the flywheel cover all the way to the depth determined by the punch.

Specific tooling**020628Y Water pump service kit**

Fit the punch with the template of the entrainment joint to the press punch.



Position the entrainment joint on the shaft and using the press, drive it to the depth determined by the punch.

Specific tooling**020628Y Water pump service kit**

Lubricate the oil seal with motor oil.

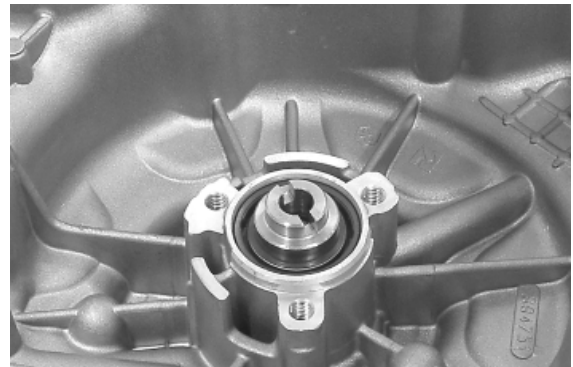
**Water pump ceramic seal**

Our Leader, Quasar, and Master liquid cooled engines are equipped with water pumps fitted with the ceramic seal in the subject. This component is intended to guarantee the leak tightness of the coolant in relation to the pump shaft. The seal achieved via two special ceramics, a static one and a spinning one, kept in contact by the thrust of a spring, coaxially mounted onto the pump shaft. The efficiency of this system is guaranteed by the accurate machining and cleaning of the components as they are fitted; in any case, ceramic seals are subjected to a running in period. During this period ($1,000 \pm 1,500$ km), there may be small leaks through draining holes, which remain visible on the aluminium crankcase. This phenomenon is particularly visible there where the hole is more exposed (Quasar and Master). In such cases we recommend cleaning the casing in order to be able to check again for leaks after a distance of more than 1500 km. If leaks continue or in the event of real losses, the ceramic seal should be replaced. For these operations, observe the tools and instructions given in the relevant service station manuals.

Note: The ceramic seal may be overhauled according to the following couplings:

- Coupling "A": seal ring no. 485084 with ceramic seal no. 486216
- Coupling "B": seal ring no. 841329 with ceramic seal no. 841330

The couplings above may be selected according to their availability, as they are interchangeable.

Removal

- Loosen the two screws indicated in the figure and remove the thermostat cover.
- Remove the thermostat with its gasket.



Check

- Visually check that the thermostat is not damaged.
- Prepare a metal container with approx. 1 litre of water.
- Immerse the thermostat, keeping it in the centre of the container.
- Immerse the multimeter temperature probe, near the thermostat.



- Warm up the container using the heat gun.
- Check the temperature when the thermostat starts to open:
- Heat up until the thermostat is completely open
- Replace the thermostat if it does not work properly.

CAUTION

TO EXECUTE THE TEST CORRECTLY, MAKE SURE NEITHER THE THERMOSTAT NOR THE THERMOMETER TOUCHES THE CONTAINER.

Specific tooling

020331Y Digital multimeter

020151Y Air heater

Characteristic

Thermostat check: opening travel

3.5 mm at 80°C

Thermostat check: Opening start temperature

69.5 ÷ 72.5°C

- 1) Look to see that the thermostat is not damaged.
- 2) Fill a metal container with approx. 1 litre of water.

Immerse the thermostat, and keep it in the centre of the container.

Immerse the multimeter temperature probe drawing No° 020331Y closeà to the thermostat.

Heat the container with a hot air gun drawing No° 020151Y.

Check the temperature when the thermostat starts to open:

Opening start temperature: 69.5 ÷72.5°C

Heat up until the thermostat is completely open.

Opening travel: 3.5 mm at 80°C

CAUTION - To execute the test correctly, make sure neither the thermostat nor the thermometer touches the container.

- 3) Replace the thermostat if it is not working properly.



Refitting

- Place the thermostat with the bleeding hole at the highest point.
- Make sure that the rubber gasket is positioned properly.
- Fit the thermostat cover with the connection for the carburettor heating pipe facing the flywheel.
- Tighten the two screw to the torque indicated below.



Locking torques (N*m)

Thermostat cover screws 3 ÷ 4

INDEX OF TOPICS

CHASSIS

CHAS

Seat

- Remove the saddle by loosening the three retaining screws indicated in the figure;



Side fairings

- Remove side bumpers by removing the mounting screws shown in the figure (one on each side).

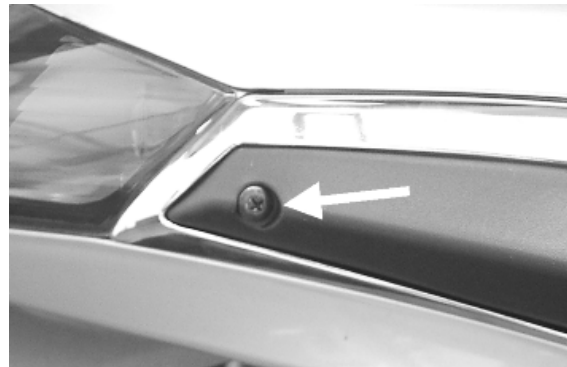

Rear rack

- Loosen the two mounting screws and remove the battery cover.
- Remove the plastic cover of the rear luggage rack by removing the two side screws from the lower side of the rack.
- Loosen the 3 hexagonal retaining screws indicated in the figure and remove luggage rack.

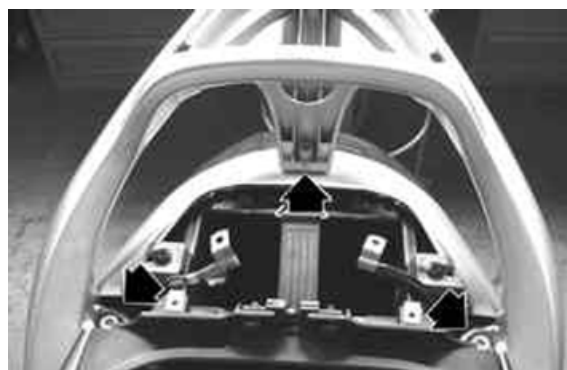

Rear handlebar cover

- Remove the front handlebar cover.
- Remove the 3 screws shown in the photograph.
- Remove the 2 screws on the rear part of the handlebar cover shown in the photograph.

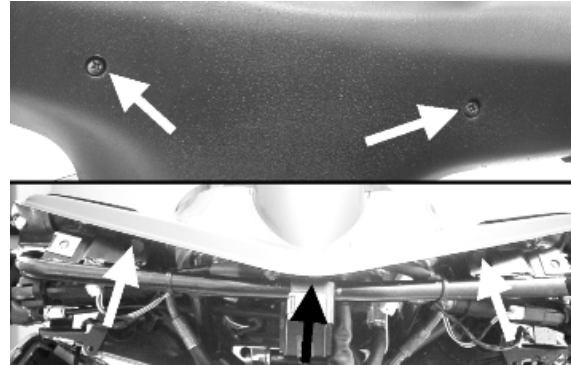

See also

[Front handlebar cover](#)
[Front handlebar cover](#)

Instrument panel

- Remove the rear handlebar cover.
- Disconnect the cable harness.
- Remove the odometer cable.
- Remove the 3 screws shown in the photograph.
- Remove the instrument panel.

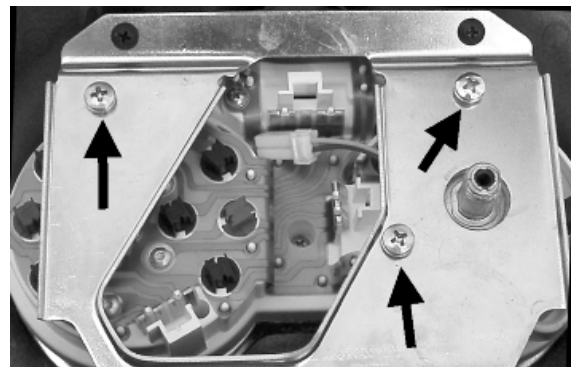

See also

[Rear handlebar cover](#)

Front handlebar cover

- Remove the 5 screws on the front part of the handlebar cover shown in the figure.
- Remove the 2 screws on the rear part of the handlebar cover shown in the figure.

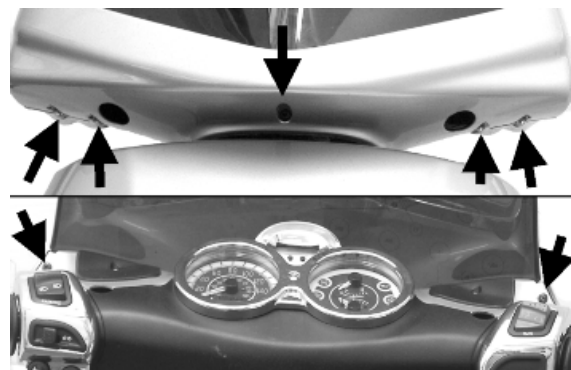

Headlight assy.

- Remove the headlight assembly by loosening the 4 fixing screws, two of which are shown in the figure and two located further down.
- Separate the electrical connectors;
- Pull out the headlight assembly.



Frame central cover

- Open the fuel tank access port.
 - Loosen the 4 screws shown in the figure.
 - At the same time, remove the fuel tank cap.
- Remove the frame central cover by sliding it from the rear side of the scooter and disconnecting it from the cover opening transmission.



Legshield

- Remove the headlight assembly.
- Remove the central frame cover.
- Remove the fixing screw of the expansion tank access cover.
- Loosen the 2 fixing screws on the upper part of the shield back plate, one of which is shown in the figure.
- Undo the remaining 2 fixing screws of the front shield with the wheel housing.



- Loosen the 2 screws shown in the figure.
- Remove the front shield.



See also

[Headlight assy.](#)

[Frame central cover](#)

Knee-guard

- Remove the front shield;
- Remove the 2 fixing screws of the fuse box in the front glove box;
- Separate the electrical connections;
- Remove the expansion tank;
- Loosen the fixing screw inside the glove box and the two screws located under the central frame cover;
- Disconnect the saddle closing mechanism;
- Remove the rear shield with the glove box.

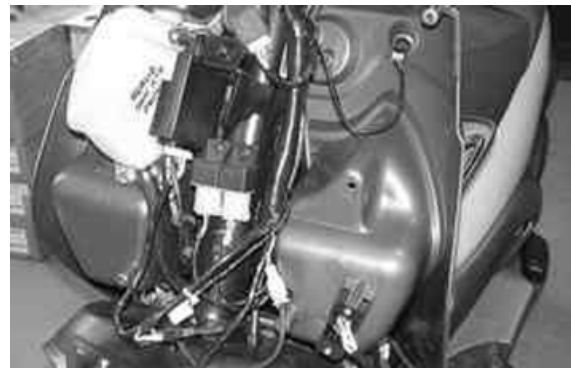

See also

[Legshield](#)

Removing the ignition key-switch when on *off*

- Remove the shield back plate.
- Remove the immobilizer aerial as shown in the figure.



- Detach the electrical wiring.
- Remove the ignition key-switch, by removing the spring retainer shown in the figure.



- Lightly push the master-cylinder and extract the lock from the notch shown in the figure.
- Hence extract the master-cylinder complete with the key-switch.
- To refit, proceed in the reverse order.



See also

[Knee-guard](#)

Removing the ignition key-switch when on *lock*

In position "Lock", it is not possible to access the cylinder retaining spring. The spring must then be removed as shown in the figure, allowing the lock spring to be pressed out.

N.B.

TO REFIT THIS ITEM, THE SCOOTER STEERING LOCK MUST BE RELEASED WITH THE LOCK BODY (INTERNAL AND EXTERNAL PART) IN POSITION "OFF". PROCEED AS DESCRIBED IN THE PREVIOUS PARAGRAPH.

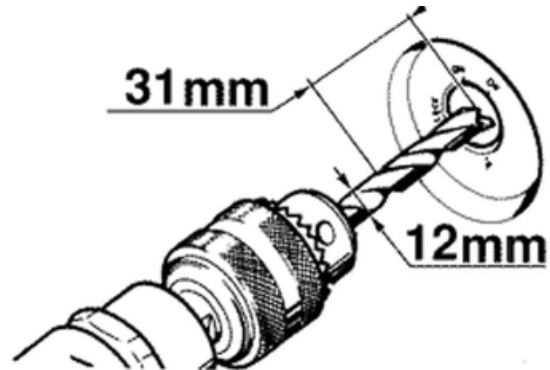

See also

[Removing the ignition key-switch when on *off*](#)

Front wheel housing

- Remove the shield back plate.
- Remove the footrests.
- Remove the front suspension.
- Loosen the remaining retaining screws holding the central chassis cover.
- Remove the radiator cover.



See also

[Removing the front wheel](#)

[Footrest](#)

[Knee-guard](#)

Taillight assy.

- Remove the cover of the luggage rack (snapped-in).
- Remove the side bumpers.
- Unscrew the 3 screws holding the rear light.
- Remove the rear light assembly after disconnecting the electrical cable harness.

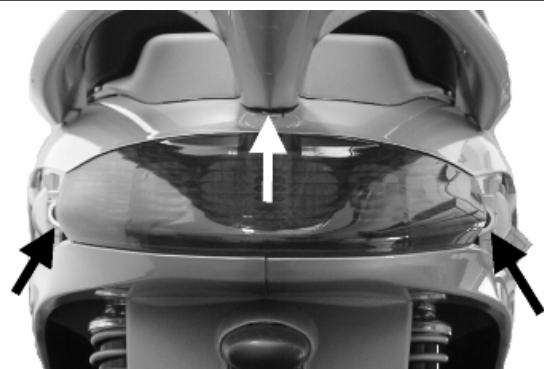

See also

[Side fairings](#)

Footrest

- Remove the central cover.
- Remove the RHS footrest mat.
- Loosen the eight footrest mounting screws.
- Remove the RHS footrest.
- Repeat the same operations for the LHS footrest.

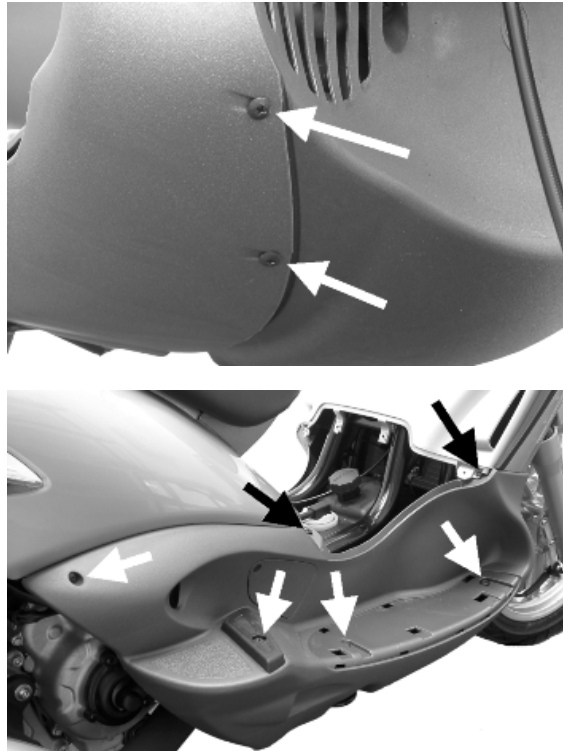

See also

[Frame central cover](#)
[Frame central cover](#)

Side fairings

- Remove the saddle.
- Remove the luggage rack.
- Remove the central cover.
- Remove the rear light assembly.
- Remove the cover under the saddle by loosening the retaining screw located under the saddle mounting plate.
- Loosen the 6 side-fairing fixing screws indicated in the 3 photographs.
- Remove the fairings.

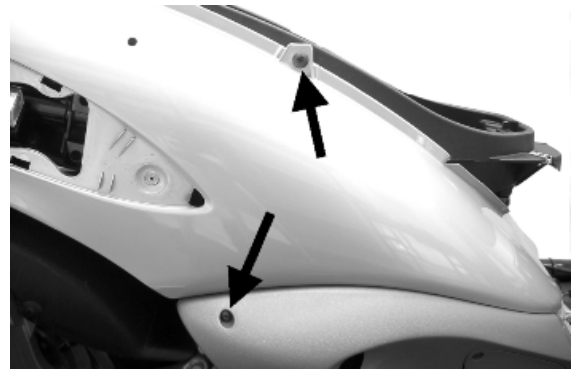

**See also**

[Seat](#)

[Rear rack](#)

[Frame central cover](#)

[Taillight assy.](#)

[Frame central cover](#)

[Rear rack](#)

[Taillight assy.](#)

[Seat](#)

Rear mudguard

- Loosen the 4 fixing screws, 2 of which are indicated in the figure and the other 2 located on the opposite side under the air filter;
- Remove the rear mudguard.



Helmet bay

- Remove the canister cover from inside the helmet compartment and hence remove all of its components (see the "Maintenance - Anti-evaporative System - Components Removal" chapter).
- Rimuovere il coperchio dell'impianto Canister all'interno del vano portacasco quindi - Remove the side panels.
- Detach the electrical connectors.
- Unscrew the eight fixing screws, four of which located inside the helmet compartment.
- Remove the number-plate holder tail after unscrewing the four fixing screws shown in the figure and disconnecting the wiring.
- Remove the helmet compartment.



See also

[Removing system components](#)

Fuel tank

- Remove the knee-guard.
- Remove the front wheel housing.
- Remove the footrest.
- Remove the roll-over valve breather tube.

N.B.

THIS OPERATION SHOULD PREFERABLY BE PERFORMED WITH THE TANK EMPTY.



- Separate the electrical connections of the fuel gauge and disconnect the fuel supply line and tank breather;
- Undo and remove the screw fixing the horn shown in the upper figure after disconnecting the electrical connection;
- Remove the toggle handles by loosening the 4 retaining screws;
- Remove the support bracket by loosening the 2 retaining screws of the bracket at the frame;



- Undo the two screws fixing the tank to the chassis;
- Remove the tank by tilting it downwards and pulling out from below.

See also

[Footrest](#)

[Knee-guard](#)

[Front wheel housing](#)

Front mudguard

- Remove the retaining screw of the cable lead through support on the right-hand side of the mudguard.
- Loosen the 3 fixing retaining screws indicated in the figure and remove the mudguard.

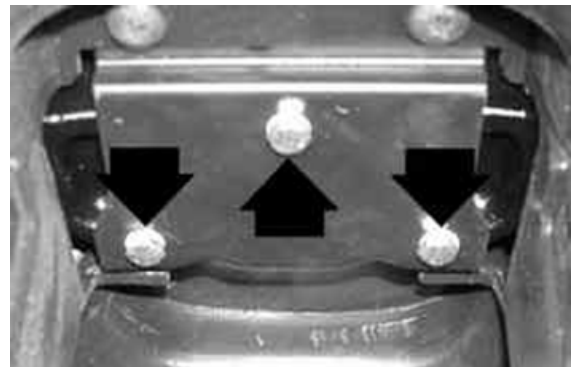

Radiator fan

- Remove the front wheel housing.
- Prepare a container for the coolant.
- Remove the expansion tank outlet and return pipes.
- Remove the coolant supply and return pipes from the radiator.
- Loosen the screw mounting the radiator to the frame.
- Disengage the radiator and the electric fan.

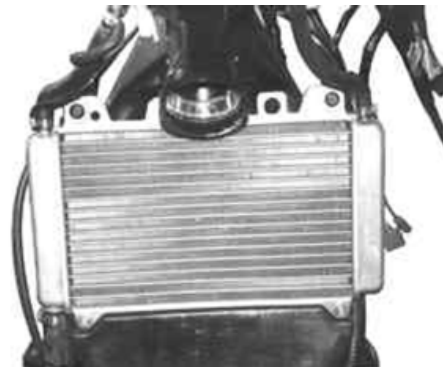

See also

[Front wheel housing](#)

Flyscreen

- Remove the front handlebar cover
- Remove the 3 screws shown in the photograph.

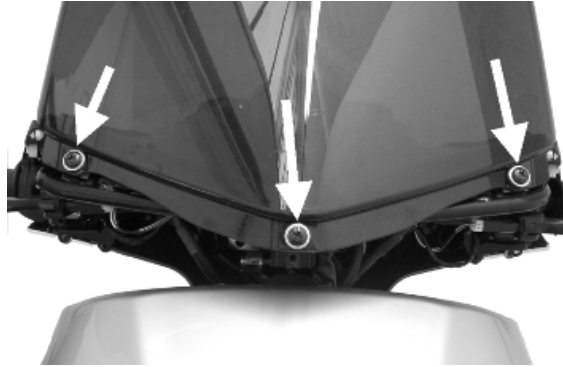

See also

[Front handlebar cover](#)

INDEX OF TOPICS

PRE-DELIVERY

PRE DE

Carry out the listed tests before delivering the vehicle.

Warning- be very careful when handling fuel.

Aesthetic inspection

Appearance check:

- Paintwork
 - Fitting of plastics
 - Scratches
 - Dirt
-

Tightening torques inspection

Lock check

- Safety locks
- clamping screws

Safety locks

Rear shock absorber upper fixing

Rear shock absorber lower fixing

Front wheel axle nut

Wheel hub nut

Frame - swinging arm bolt *

Swinging arm bolt - Engine

Engine arm pin - Frame arm

Handlebar lock nut

Steering lower ring nut

Upper steering ring nut

Electrical system

Electrical system

- Main switch
 - Headlamps: high beam, low beam, position and parking lights and the respective warning lights
 - Adjusting the headlights according to the regulations currently in force
 - Tail light, parking light, stop light
 - Front and rear stop light switches
 - Turn indicators and their warning lights
 - Instrument lighting
 - Instrument panel: fuel and temperature indicator
 - Instrument panel warning lights
-

- Horn

- Starter

CAUTION

TO ENSURE MAXIMUM PERFORMANCE, THE BATTERY MUST BE CHARGED BEFORE USE. INADEQUATE CHARGING OF THE BATTERY WITH A LOW LEVEL OF ELECTROLYTE BEFORE IT IS FIRST USED SHORTENS THE LIFE OF THE BATTERY.

WARNING

BEFORE RECHARGING THE BATTERY, REMOVE THE CAPS OF EACH CELL. KEEP THE BATTERY AWAY FROM NAKED FLAMES OR SPARKS WHILE IT IS CHARGED. REMOVE THE BATTERY FROM THE SCOOTER, DISCONNECTING THE NEGATIVE TERMINAL FIRST.

CAUTION

WHEN INSTALLING THE BATTERY, ATTACH THE POSITIVE LEAD FIRST AND THEN THE NEGATIVE LEAD.

WARNING

BATTERY ELECTROLYTE IS TOXIC AND IT MAY CAUSE SERIOUS BURNS. IT CONTAINS SULPHURIC ACID. AVOID CONTACT WITH EYES, SKIN AND CLOTHING.

IN CASE OF CONTACT WITH EYES OR SKIN, RINSE WITH ABUNDANT WATER FOR ABOUT 15 MINUTES AND SEEK MEDICAL ATTENTION AT ONCE.

IF IT IS SWALLOWED, IMMEDIATELY DRINK LARGE QUANTITIES OF WATER OR VEGETABLE OIL. SEEK IMMEDIATE MEDICAL ATTENTION.

THE BATTERIES PRODUCE EXPLOSIVE GAS; KEEP THEM AWAY FROM NAKED FLAMES, SPARKS AND CIGARETTES. IF THE BATTERY IS CHARGED IN A CLOSED PLACE, TAKE CARE TO ENSURE ADEQUATE VENTILATION. ALWAYS PROTECT YOUR EYES WHEN WORKING CLOSE TO BATTERIES.

KEEP OUT OF THE REACH OF CHILDREN

CAUTION

NEVER USE FUSES WITH A CAPACITY HIGHER THAN THE RECOMMENDED CAPACITY. USING A FUSE OF UNSUITABLE RATING MAY SERIOUSLY DAMAGE THE VEHICLE OR EVEN CAUSE A FIRE.

Levels check

Level check:

- Hydraulic braking system fluid level.
 - Rear hub oil level
 - Engine coolant level.
-

Road test

Test ride

- Cold start
 - Instrument operations
 - Response to the throttle control
 - Stability on acceleration and braking
 - Rear and front brake efficiency
 - Rear and front suspension efficiency
-

- Abnormal noise
-

Static test

Static control after the test ride:

- Starting when warm
- Starter operation
- Minimum hold (turning the handlebar)
- Uniform turning of the steering
- Possible leaks

CAUTION

CHECK AND ADJUST TYRE PRESSURE WITH TYRES AT AMBIENT TEMPERATURE.

CAUTION

NEVER EXCEED THE RECOMMENDED INFLATION PRESSURES OR TYRES MAY BURST.

Functional inspection

Functional check up:

Braking system (hydraulic)

- Lever travel

Braking system (mechanical)

- Lever travel

Clutch

- Proper functioning check

Engine

- Throttle travel check

Others

- Check documentation
 - Check the frame and engine numbers
 - Tool kit
 - License plate fitting
 - Check locks
 - Check tyre pressures
 - Installation of mirrors and any accessories
-

INDEX OF TOPICS

TIME

TIME

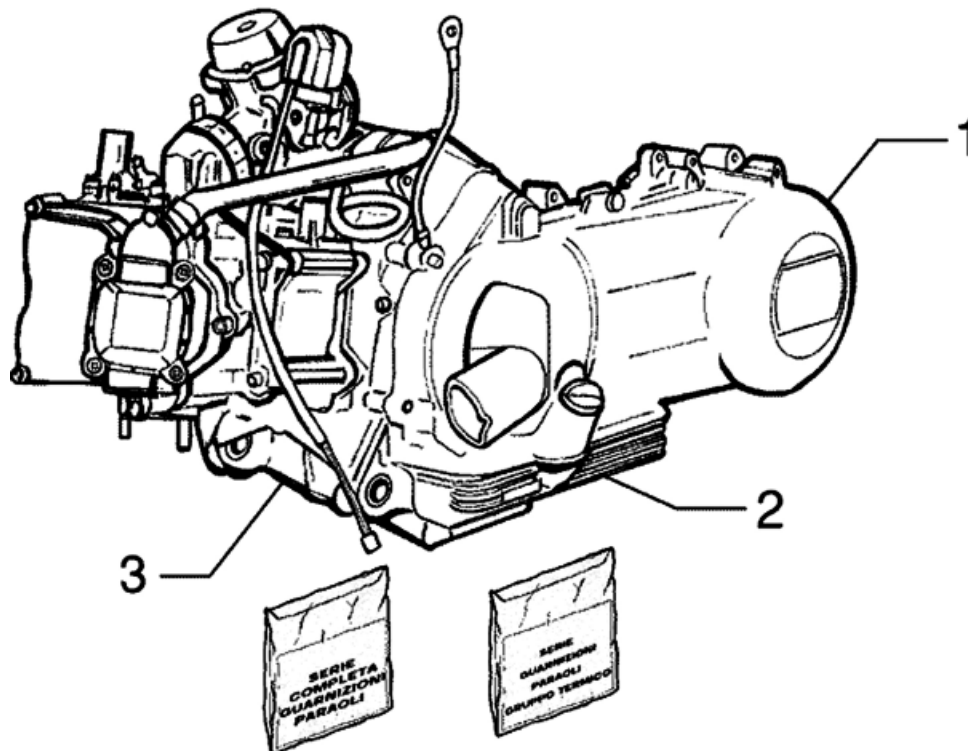
Engine
**ENGINE**

	Code	Action	Duration
1	001001	Engine from frame - remove and install	
2	003064	Engine oil - change	
3	003057	Engine retainer - tighten nuts	

Crankcase

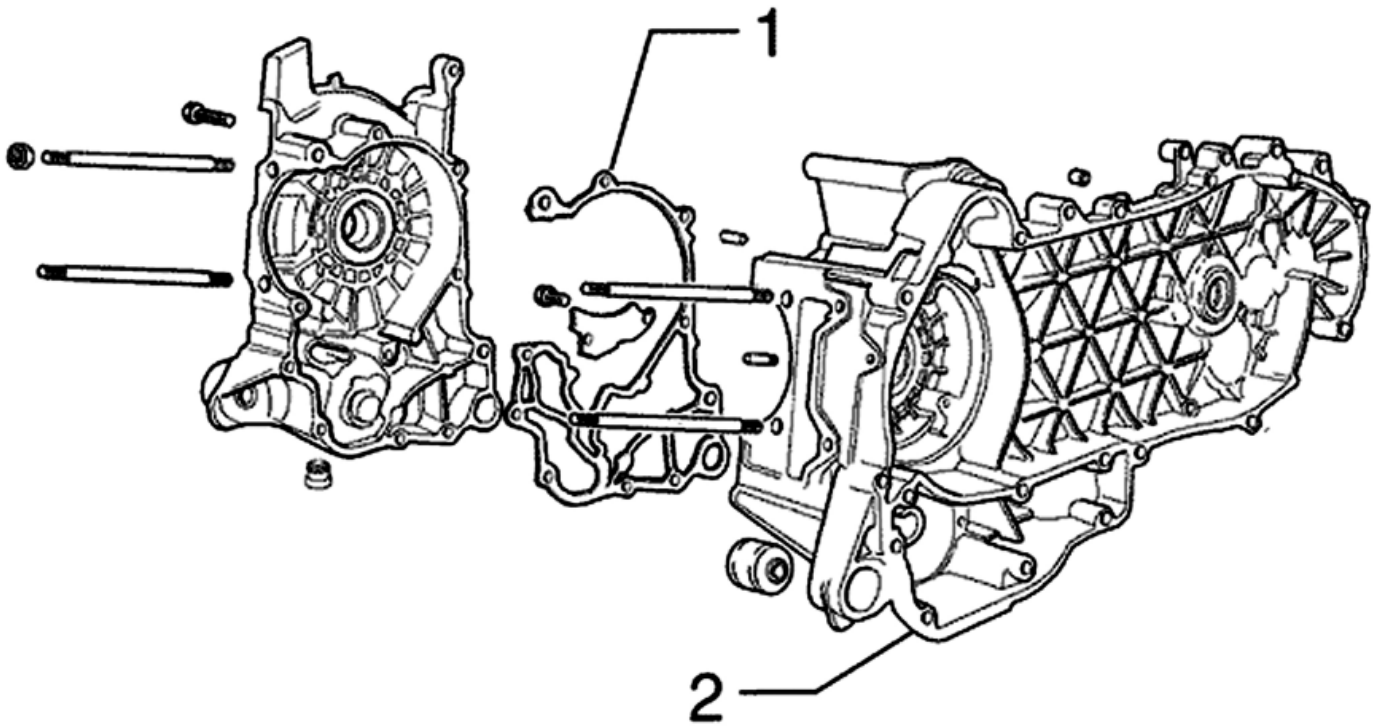

CRANKCASE

	Code	Action	Duration
1	001153	Crankcase halves gasket - Replacement	
2	001133	Engine crankcase - replace	

Crankshaft

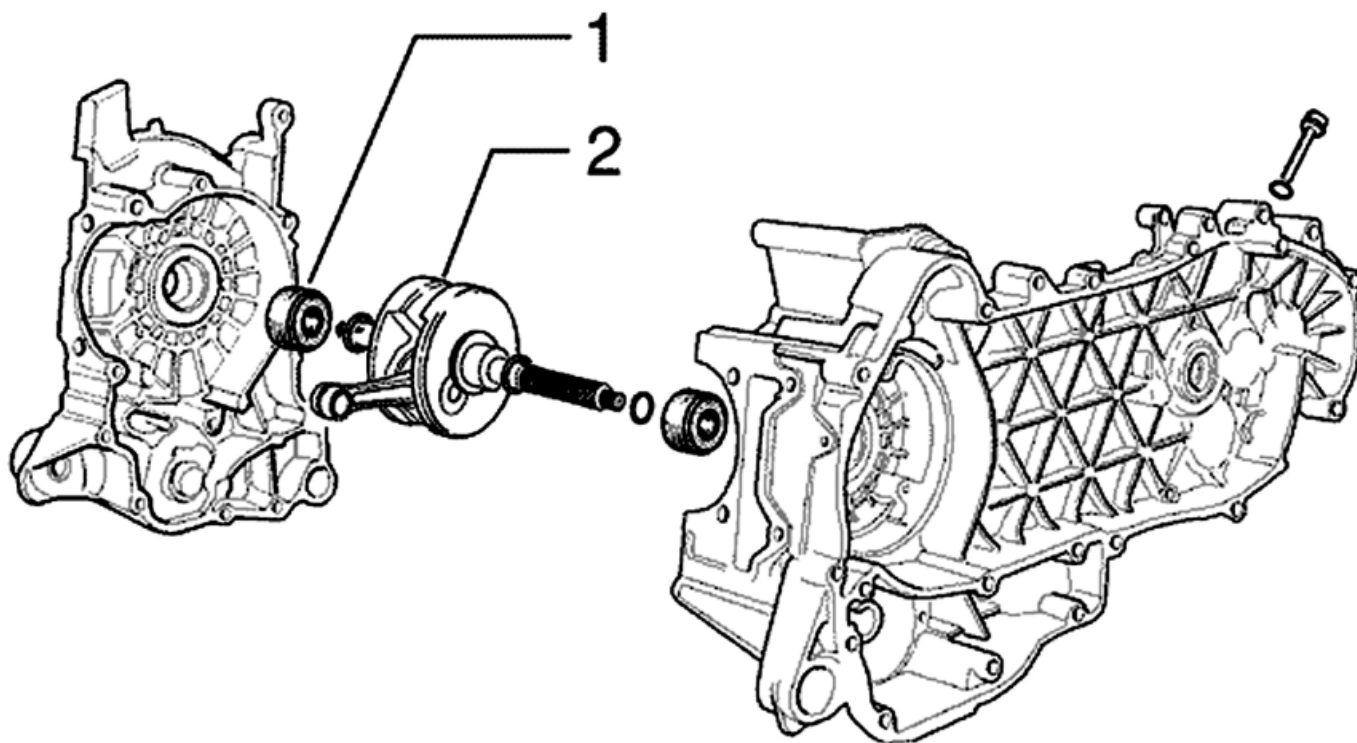

CRANKSHAFT

	Code	Action	Duration
1	001099	Oil seal, flywheel side - Replacement	
2	001117	Crankshaft - Replacement	

Cylinder assy.

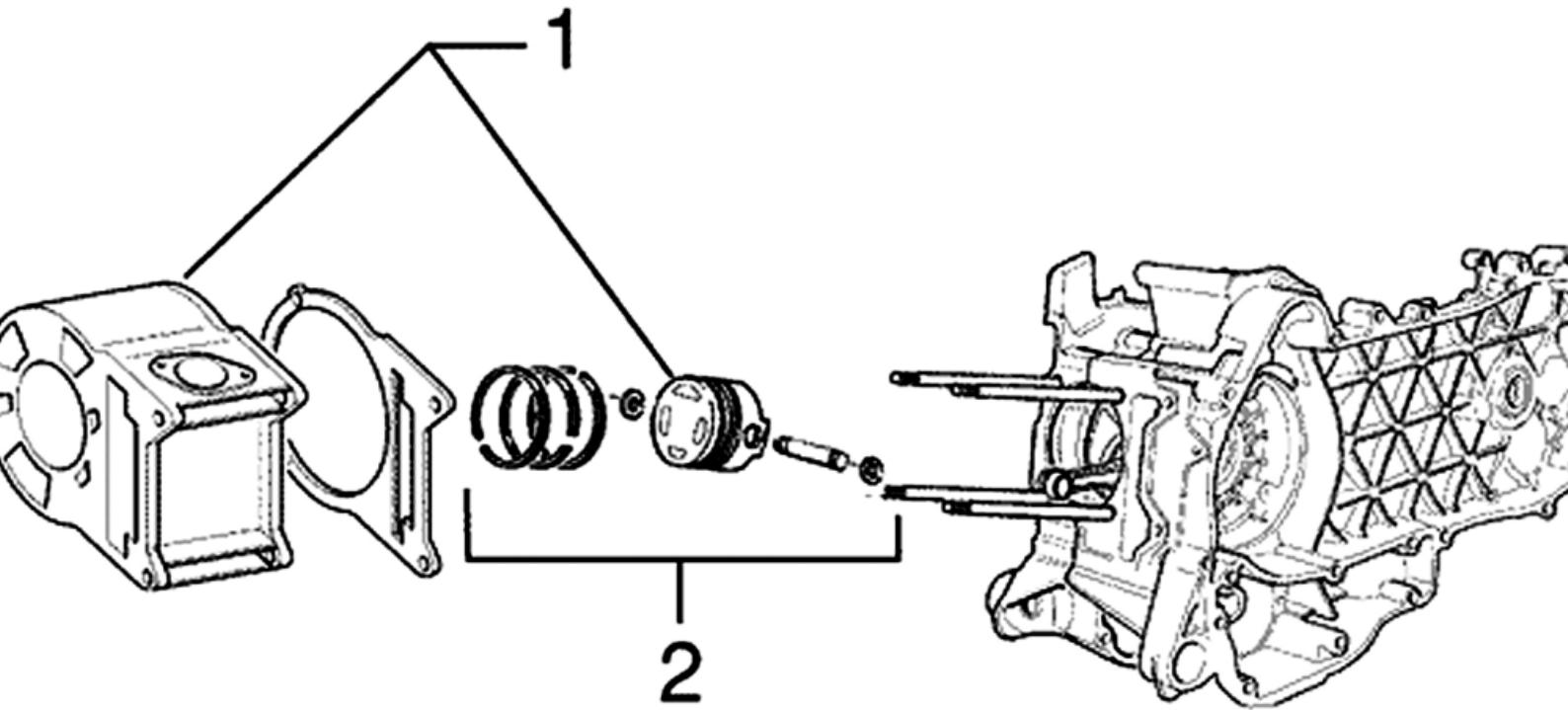

CYLINDER- PISTON

	Code	Action	Duration
1	001002	Cylinder-Piston - Replacement	
2	001154	Pin ring piston unit - Service	

Cylinder head assy.

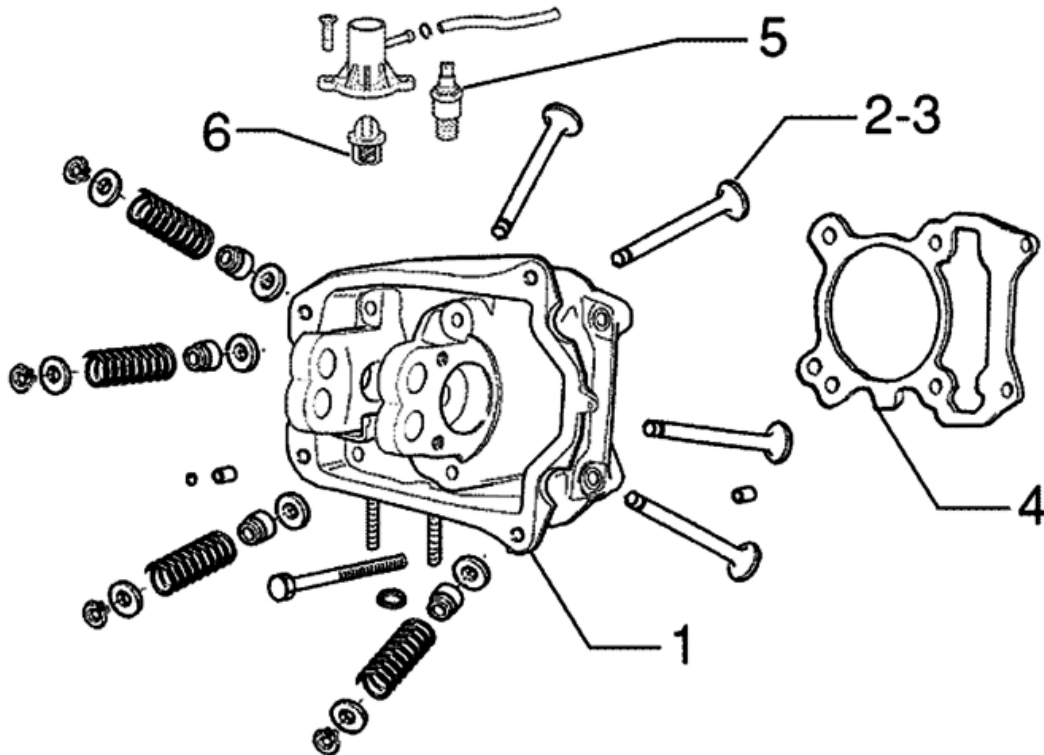
VALVE HEAD

	Code	Action	Duration
1	001126	Head - Replacement	
2	001045	Valves - Replacement	
3	001049	Valves - Adjustment	
4	001056	Head gasket - change	
5	001083	Thermistor - Replacement	
6	001057	Thermostat - Replacement	

Rocker arms support assy.

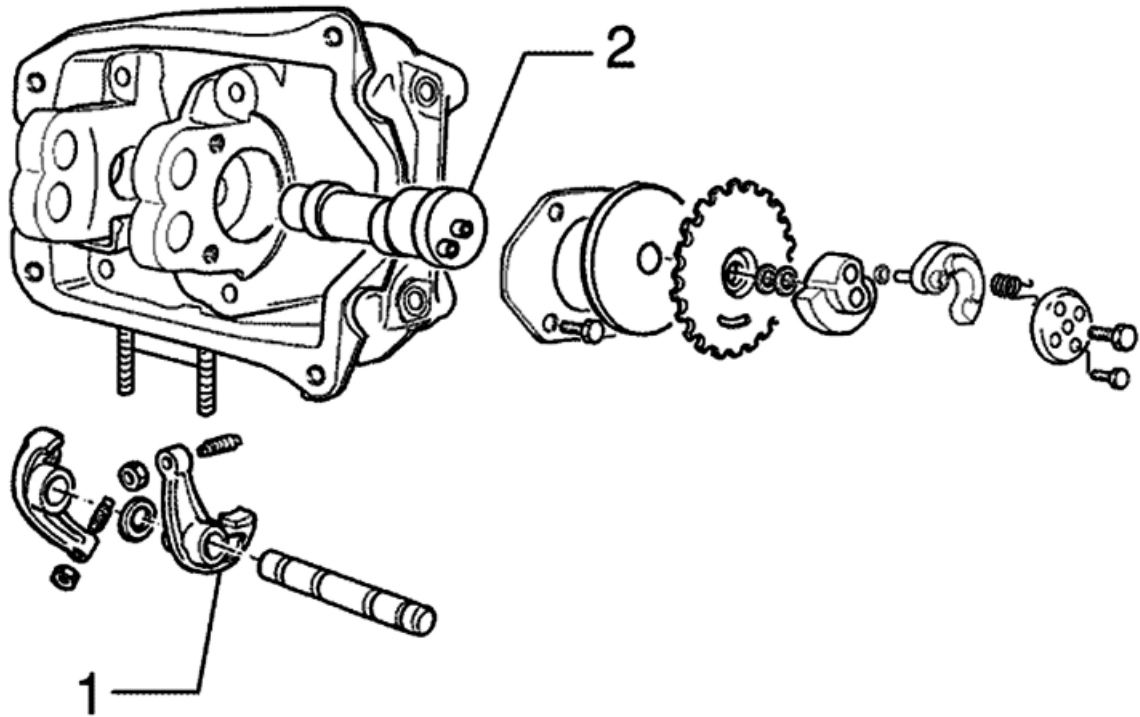

CAMSHAFT - ROCKING LEVERS

	Code	Action	Duration
1	001148	Valve rocking levers - Replacement	
2	001044	Camshaft - Replacement	

Cylinder head cover

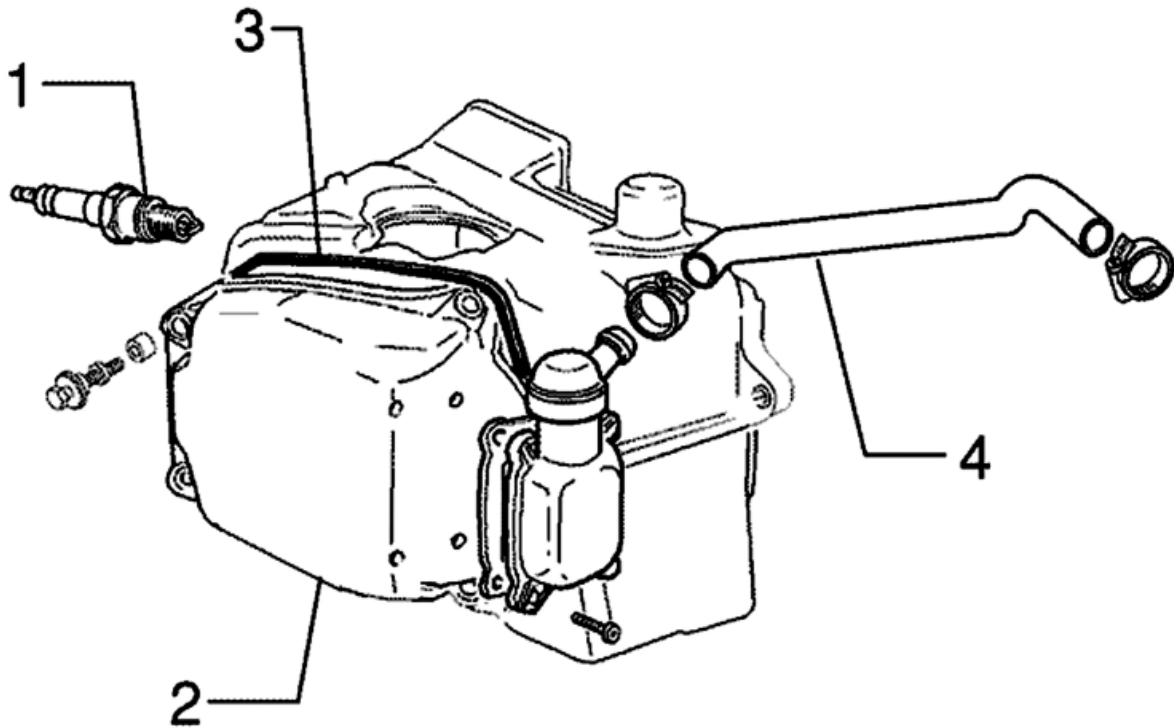
**HEAD COVER**

	Code	Action	Duration
1	001093	Spark plug - Replacement	
2	001089	Head cover - Replacement	
3	001088	Head cover gasket - Replacement	
4	001074	Oil vapour recovery pipe - Replacement	

Chain tensioner

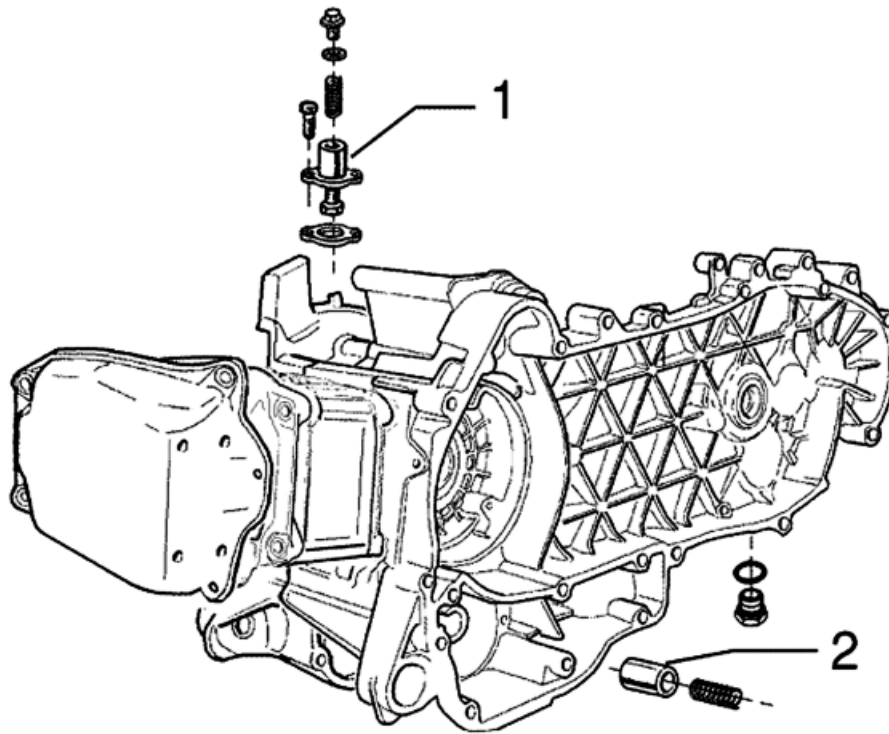

CHAIN TIGHTENER

	Code	Action	Duration
1	001129	Chain tensioner - Service and Replacement	
2	001124	By pass lubrication - Replacement	

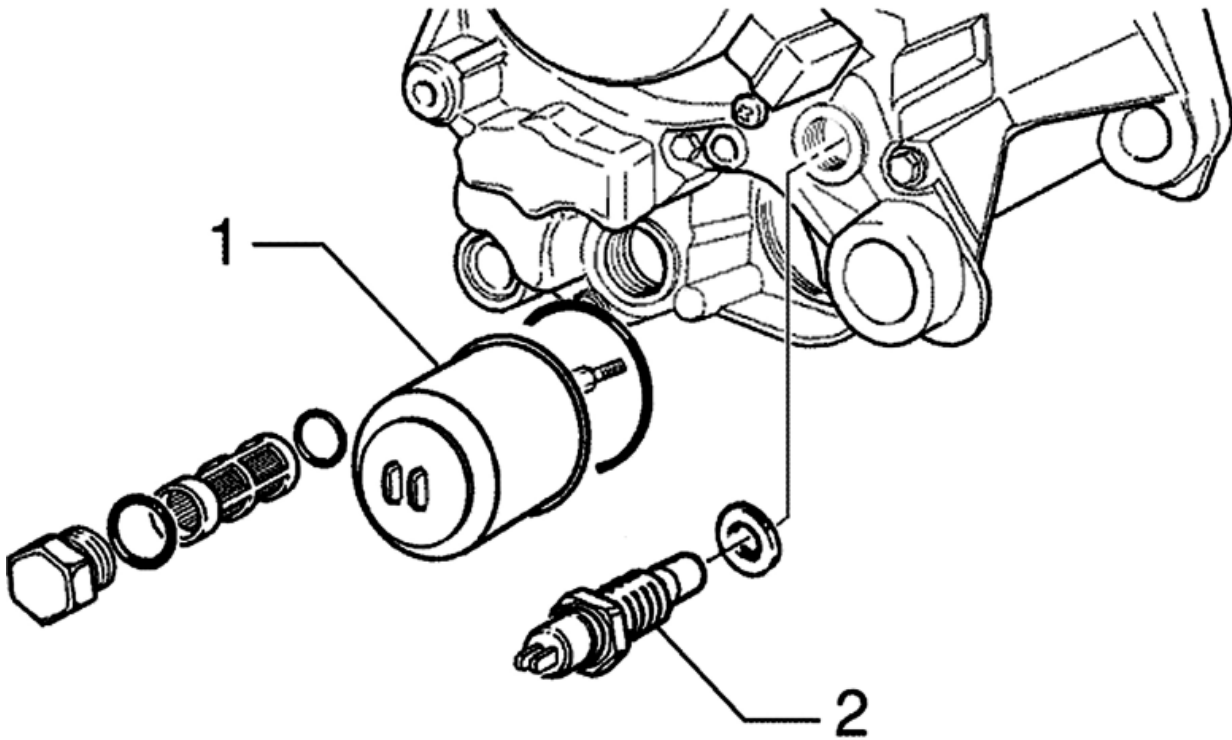
Oil filter**OIL FILTER**

	Code	Action	Duration
1	001123	Oil filter - Replacement	
2	001160	Oil pressure sensor - Replacement	

Driven pulley

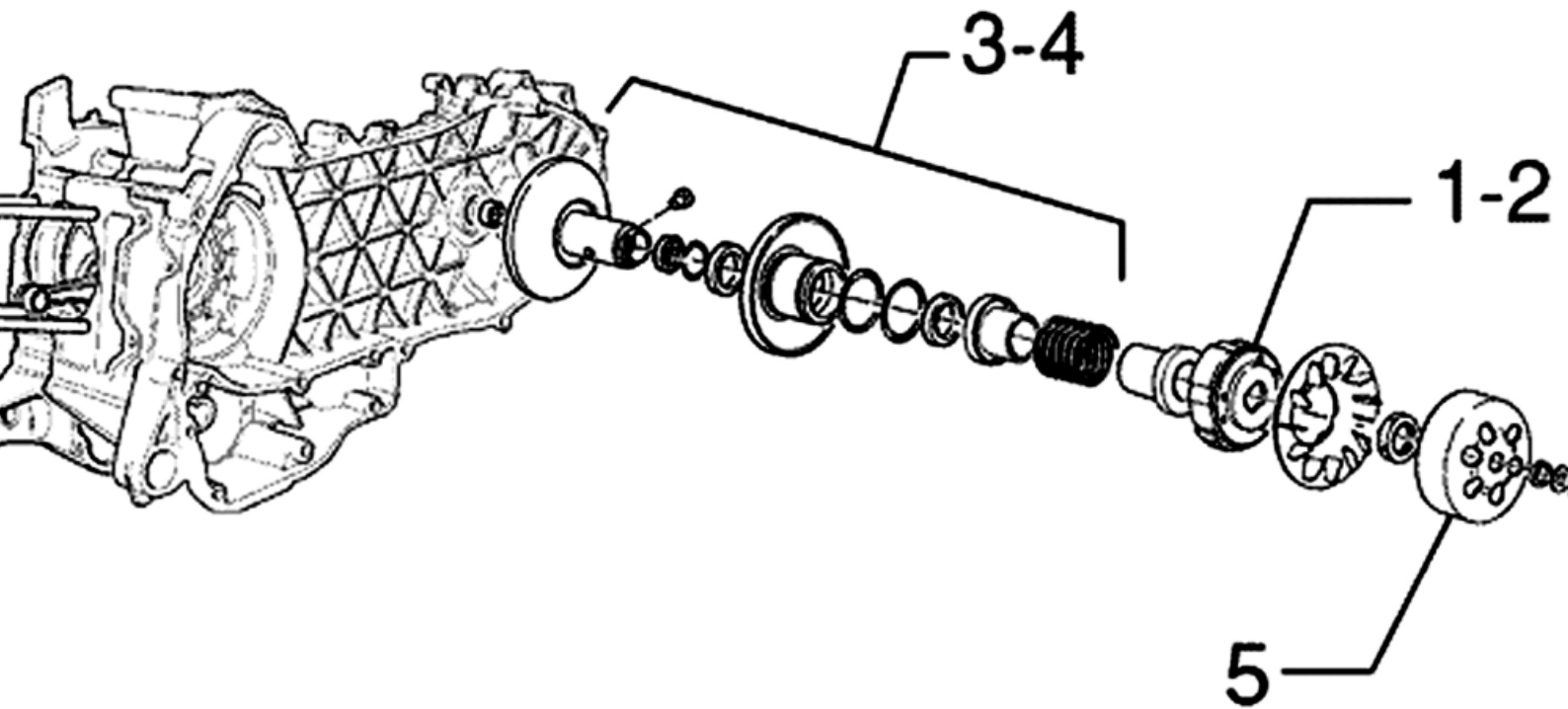

DRIVEN PULLEY

	Code	Action	Duration
1	001022	Clutch - Replacement	
2	003072	Clutch unit - Wear check	
3	001012	Driven pulley - overhaul	
4	001110	Driven pulley - Replacement	
5	001155	Clutch bell housing - Replacement	

Oil pump

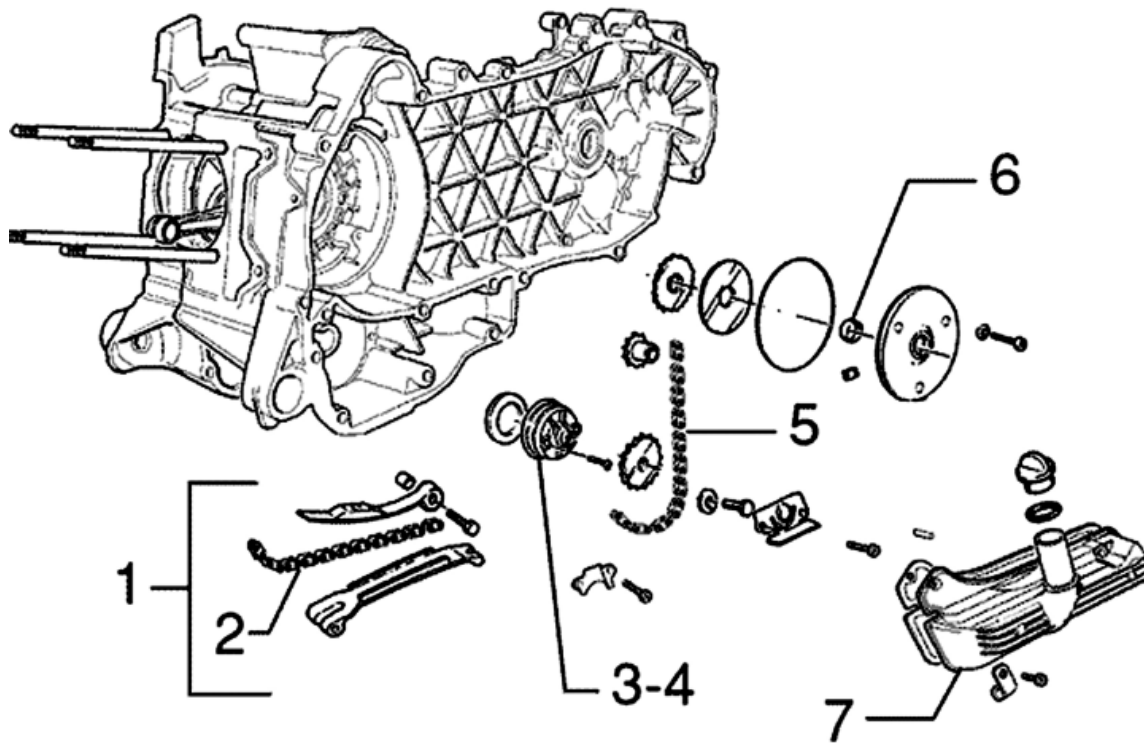
**PUMP - OIL SUMP UNIT**

	Code	Action	Duration
1	001125	Chain guide pads - Replacement	
2	001051	Belt/ Timing chain - Replacement	
3	001042	Oil pump - overhaul	
4	001112	Oil pump - change	
5	001122	Oil pump chain - Replacement	
6	001121	Chain cover oil seal - Replacement	
7	001130	Oil sump - change	

Final gear assy.

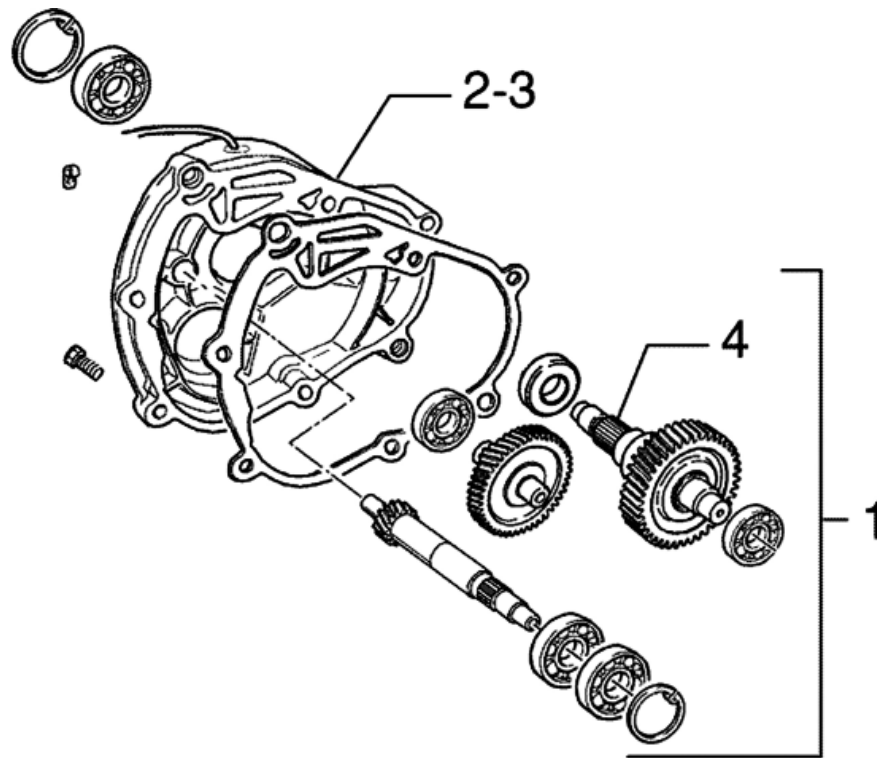

FINAL DRIVE

	Code	Action	Duration
1	001010	Gear reduction unit - Inspection	
2	001156	Gear reduction unit cover - Replacement	
3	003065	Gear box oil - Replacement	
4	004125	Rear wheel axle - Replacement	

Driving pulley

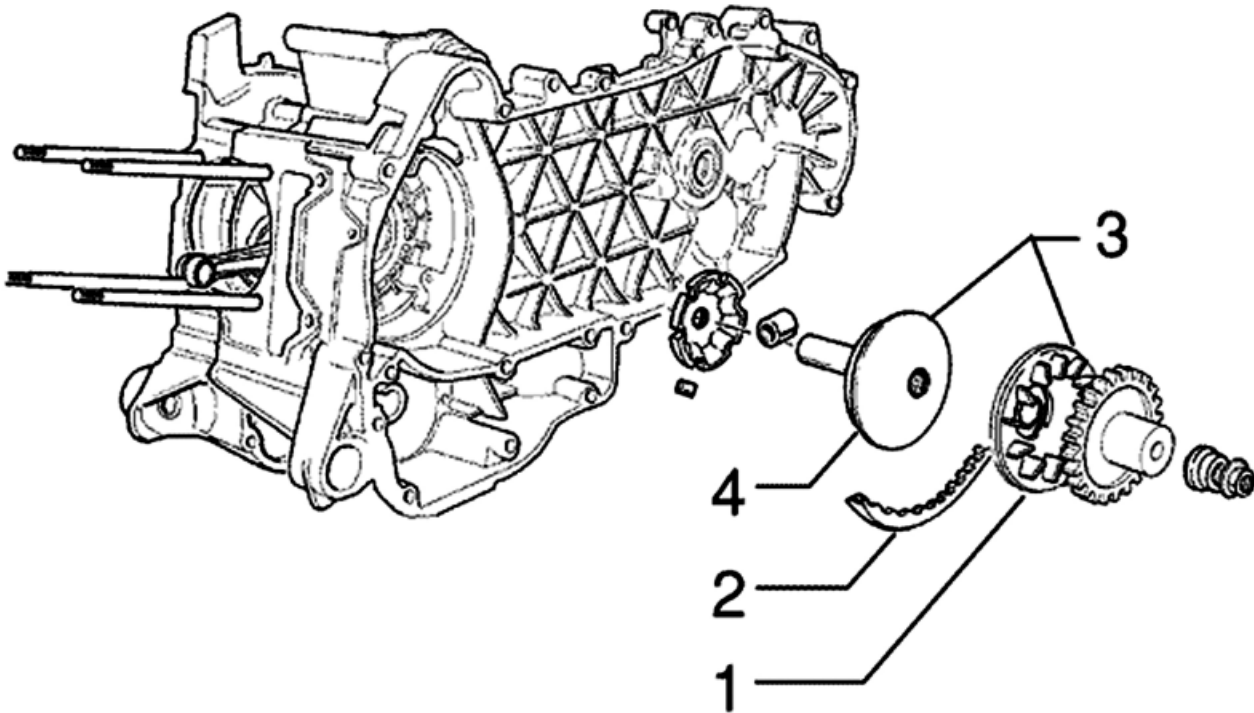

DRIVING PULLEY

	Code	Action	Duration
1	001086	Driving half-pulley - Replacement	
2	001011	Driving belt - Replacement	
3	001066	Driving pulley - Removal and Refitting	
4	001006	driving pulley - Service	

Transmission cover

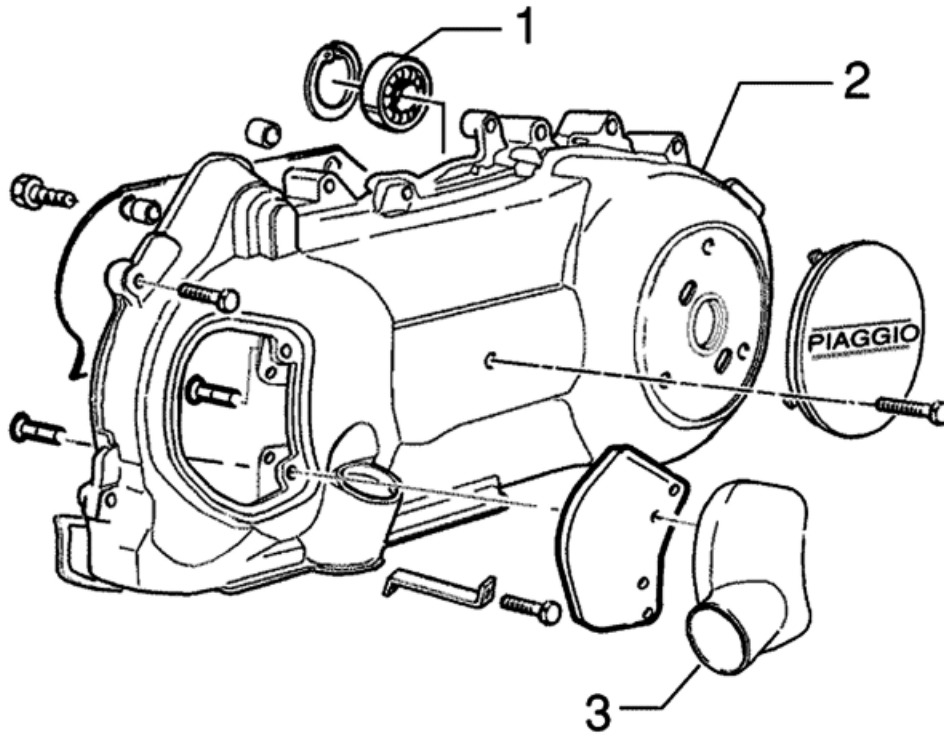

TRANSMISSION COVER

	Code	Action	Duration
1	001135	Transmission cover bearing - Replacement	
2	001096	Transmission crankcase cover - replace	
3	001131	Transmission air intake - Replacement	

Flywheel magneto

Versione 250

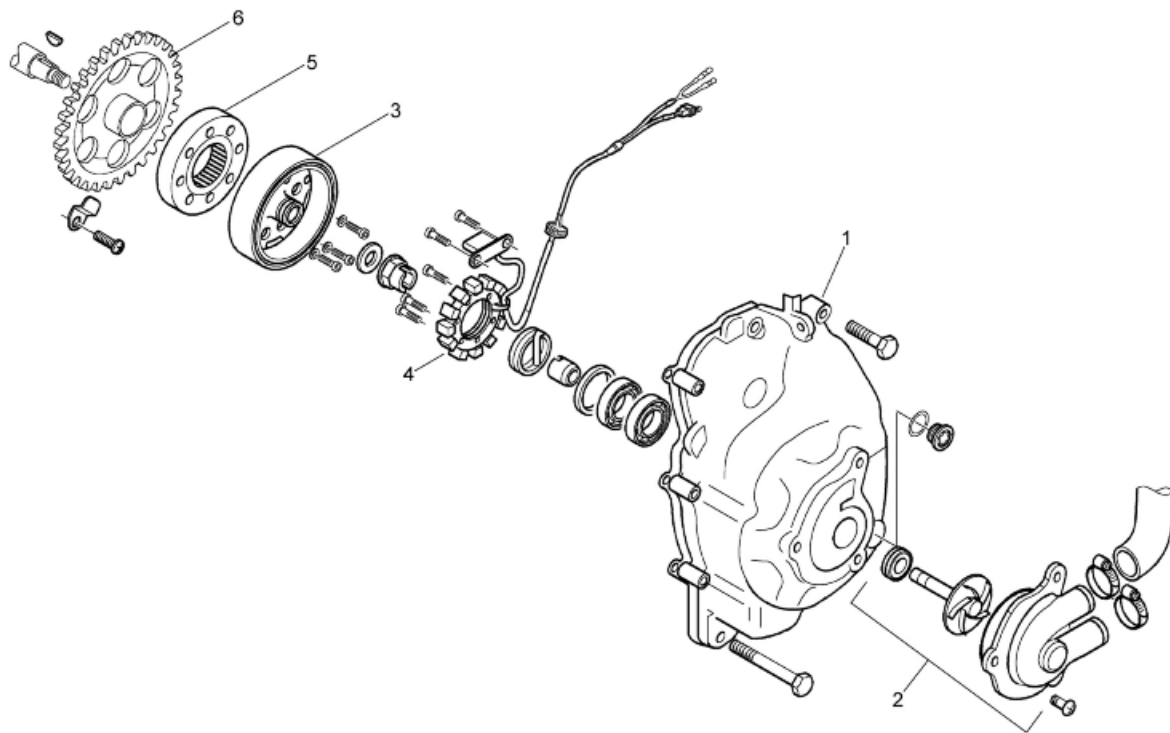

MAGNETO FLYWHEEL

	Code	Action	Duration
1	001087	Flywheel cover - replace	
2	001113	Water pump - Replacement	
3	001173	Rotor - replace	
4	001067	Stator - Replacement	
5	001104	Start-up freewheel - Replacement	
6	001151	Start-up driven gearing - Replacement	

Versione 125

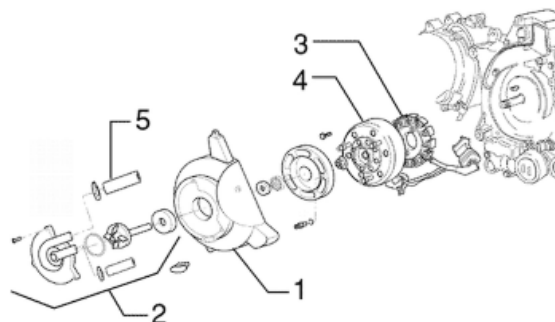

MAGNETO FLYWHEEL AND SECONDARY AIR

	Code	Action	Duration
1	001087	Flywheel cover - replace	
2	001113	Water pump - Replacement	
3	001058	Flywheel - Replacement	

	Code	Action	Duration
4	001173	Rotor - Replacement	
5	001067	Stator - Replacement	
6	001161	Secondary air filters - Replacement / Cleaning	
7	001162	Secondary air housing - Replacement	
8	001174	SAS valve - Replacement	
9	001163	SAS valve / Head connection - Replacement	

Carburettor

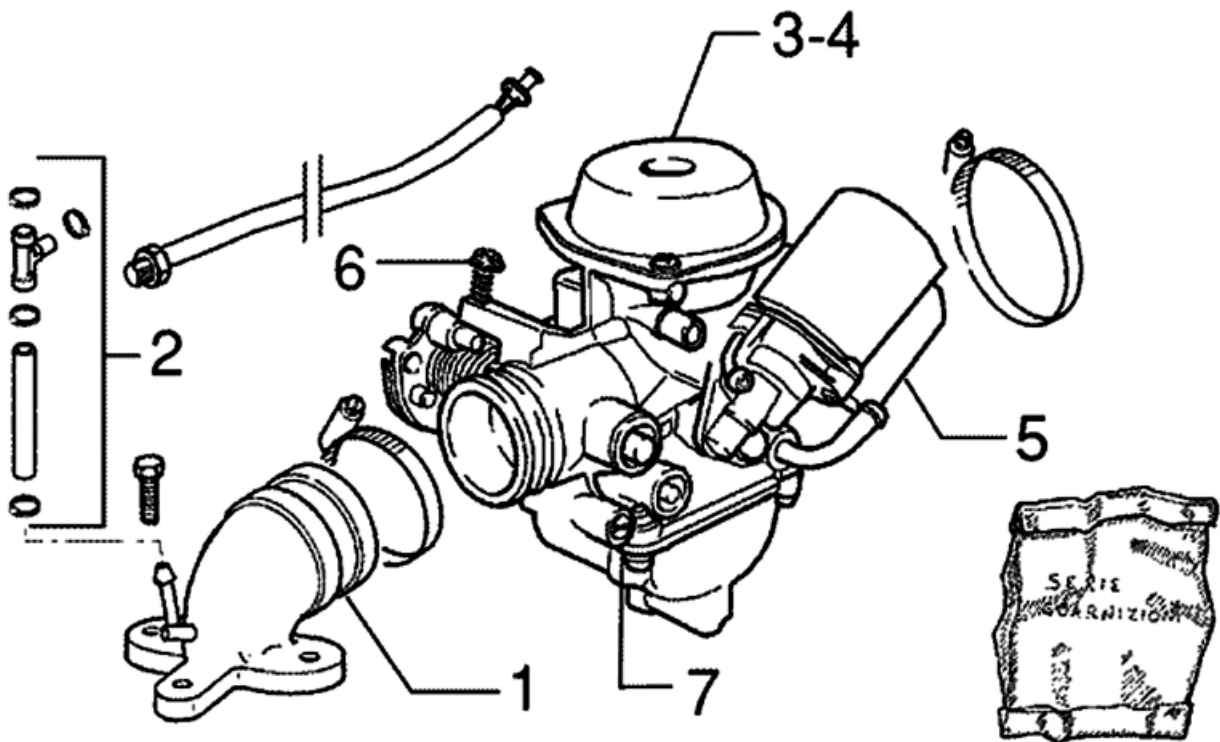

CARBURETTOR

	Code	Action	Duration
1	001013	Intake manifold - change	
2	007020	Carburettor heat. pipes - Replacement	
3	001008	Carburettor - Inspection	
4	001063	Carburettor - Replacement	
5	001081	Automatic choke - Replacement	
6	003058	Carburettor - Adjustment	
7	001136	Exhaust emissions - Adjustment	

Exhaust pipe

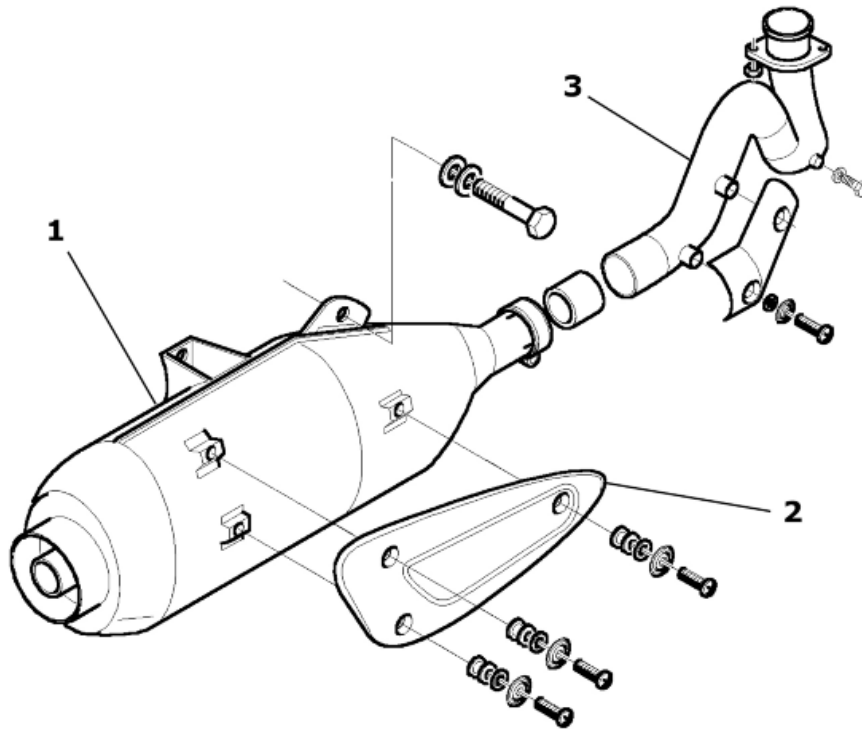

MUFFLER

	Code	Action	Duration
1	001009	Muffler - Replacement	
2	001095	Muffler guard - Replacement	
3	001092	Exhaust manifold - Replacement	

Air cleaner

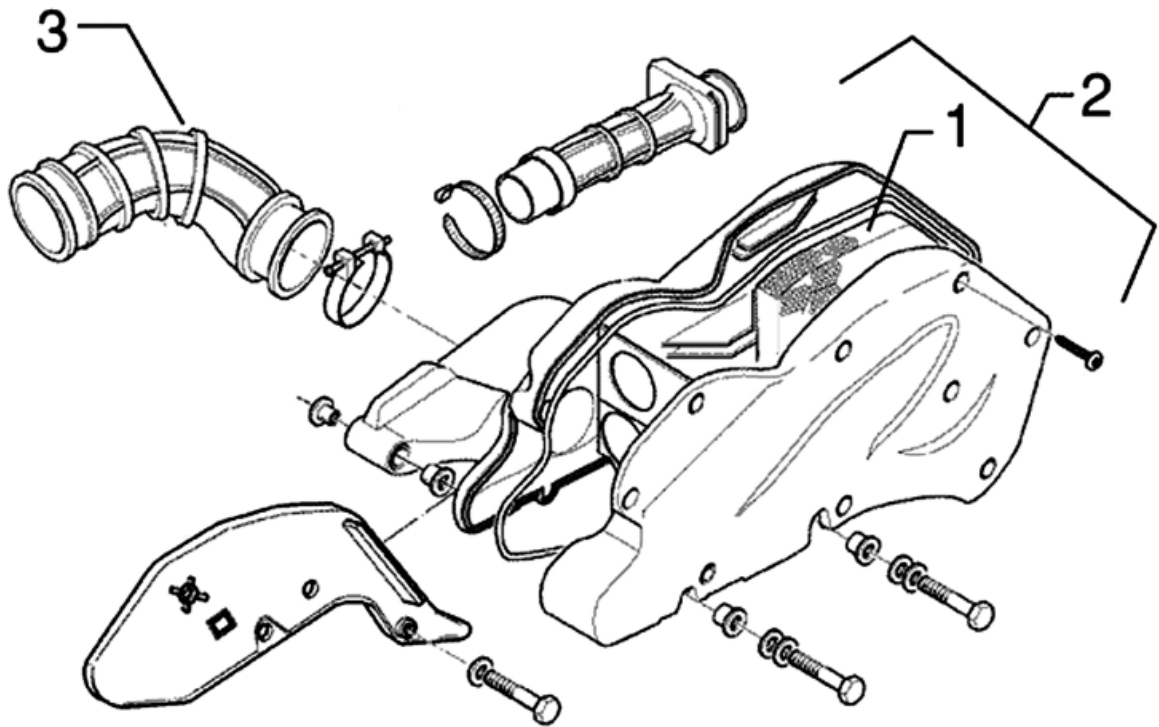

AIR CLEANER

	Code	Action	Duration
1	001014	Air filter - Replacement/ Cleaning	
2	001015	Air filter box - Replacement	
3	004122	Carburettor air cleaner at- tachment - Replacement	

Frame

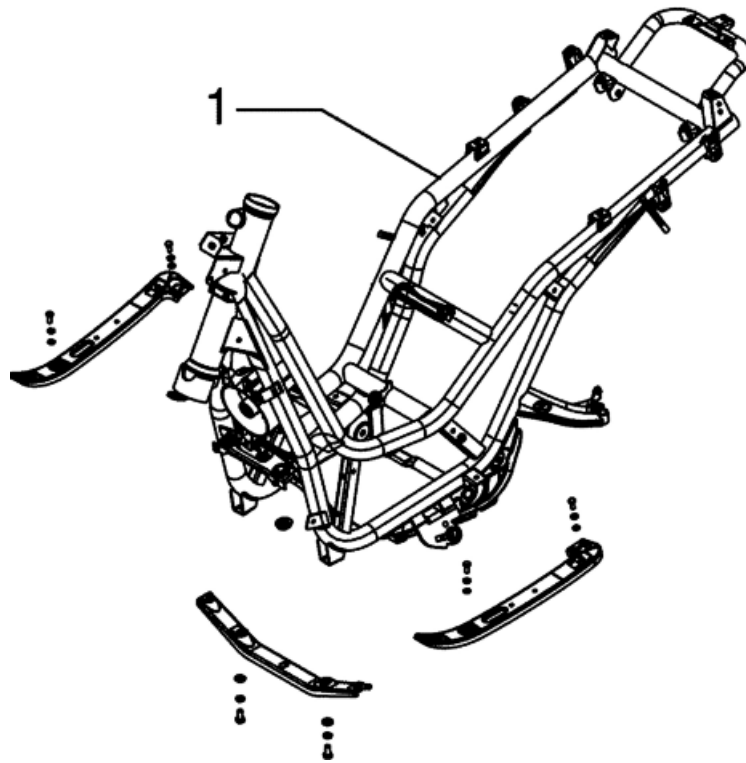

FRAME

	Code	Action	Duration
1	004001	Frame - Replacement	

Centre-stand

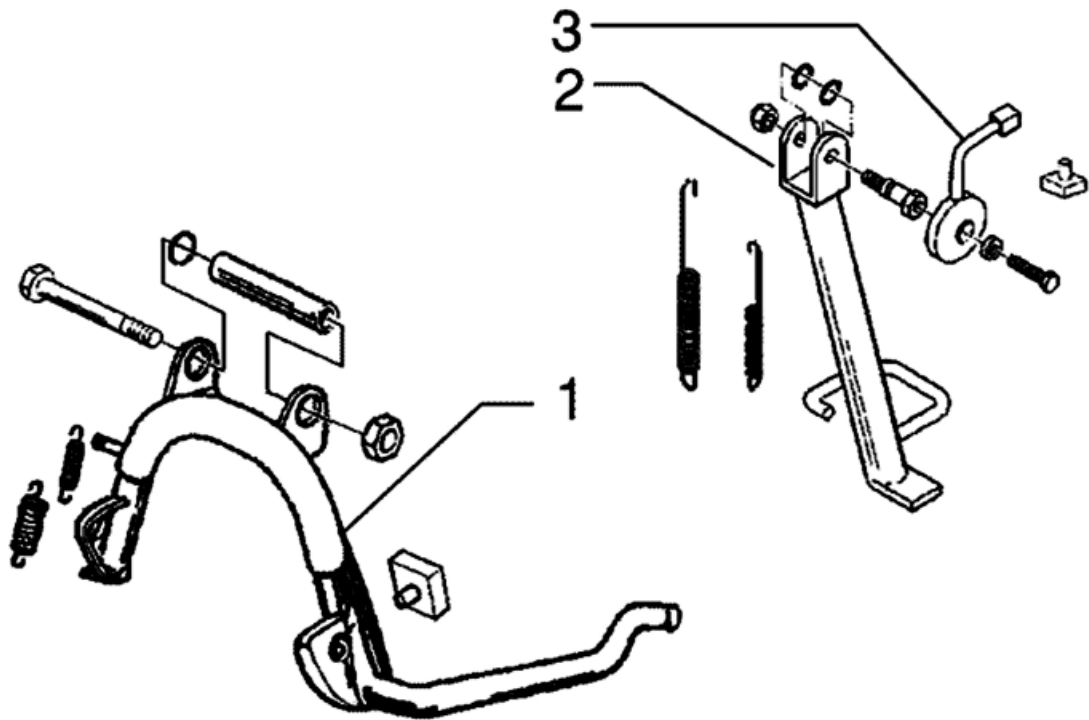

CENTRE AND SIDE STANDS

	Code	Action	Duration
1	004004	Stand - Replacement	
2	004102	Side stand - Replacement	
3	005079	Stand switch - Replacement	

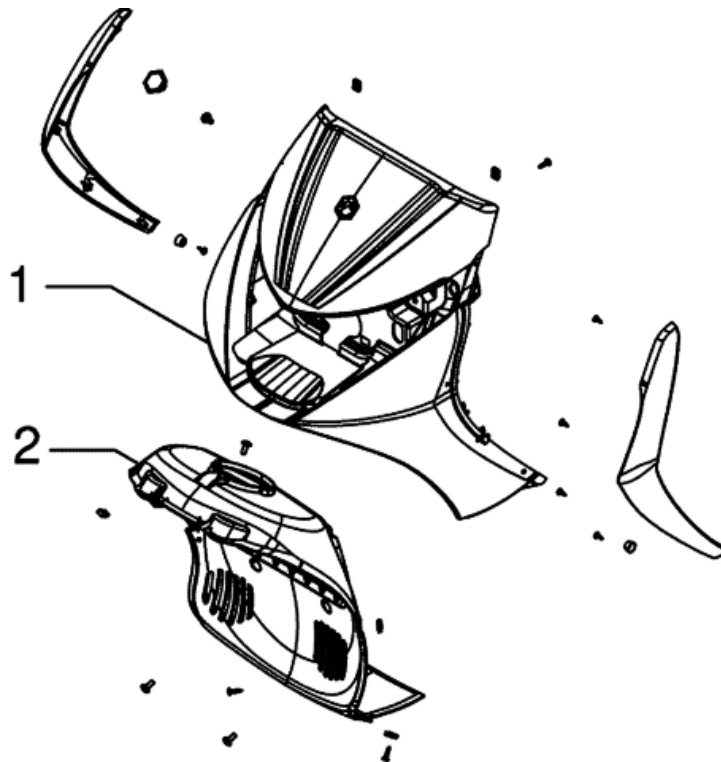
Legshield spoiler**FRONT SHIELD - SPOILER**

	Code	Action	Duration
1	004064	Front shield - Replacement	
2	004053	Spoiler - Replacement	

Side fairings

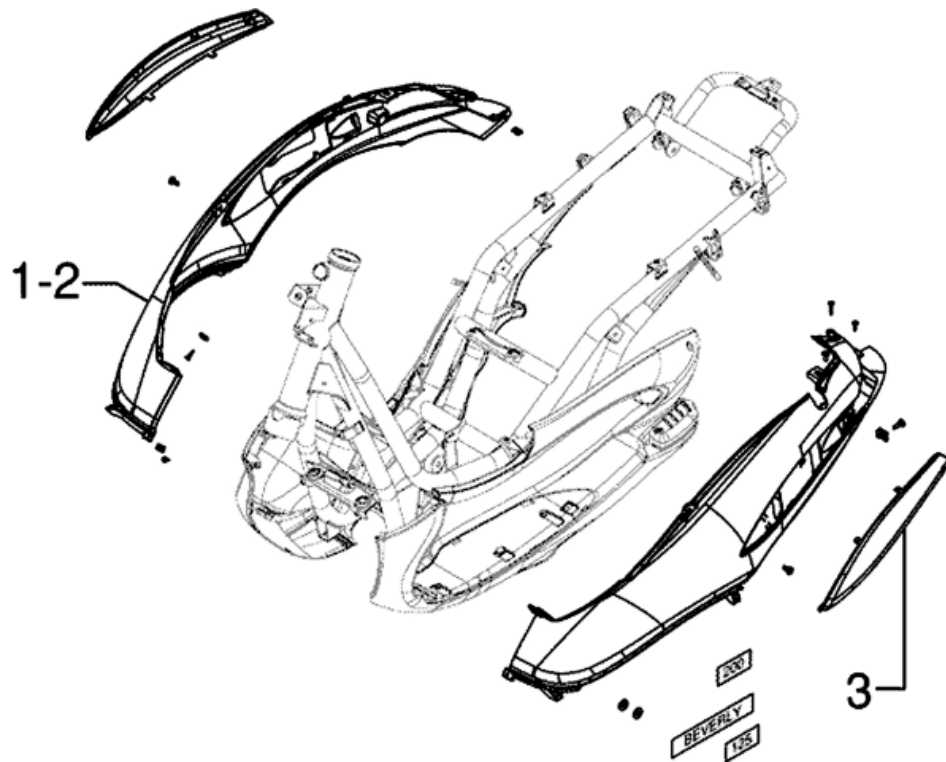

SIDE COVERS

	Code	Action	Duration
1	004085	Fairing (1) - Replacement	
2	004012	Rear side panels - Replacement	
3	004052	Bumper - Replacement	

Footrests

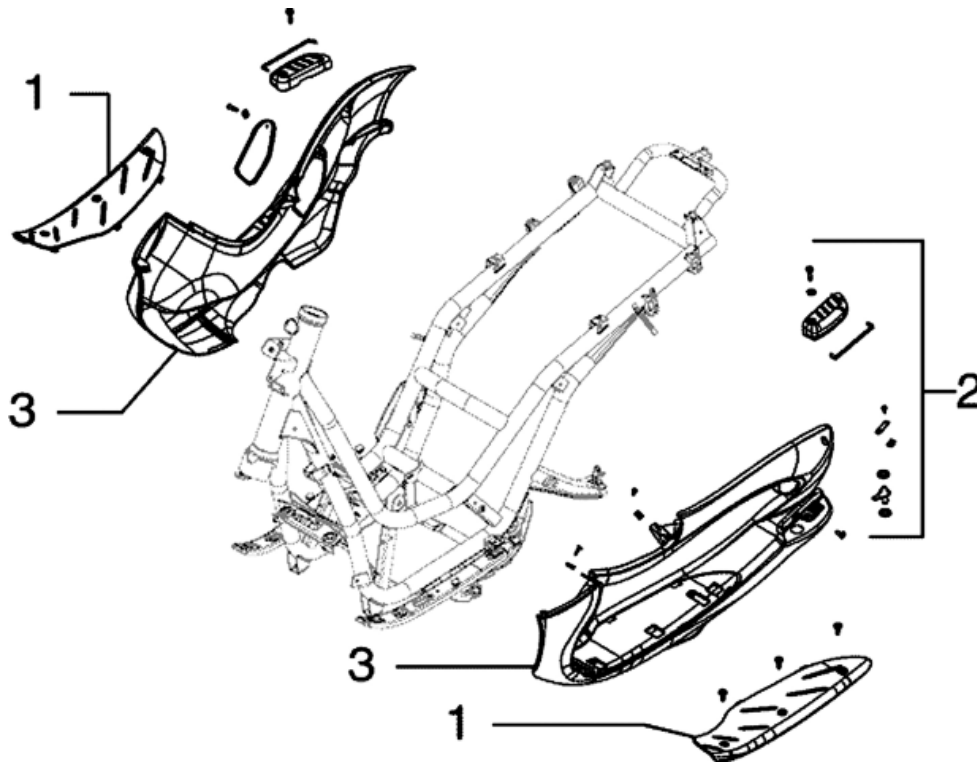
**MATS AND COVERS**

	Code	Action	Duration
1	004075	Front mat - Replacement	
2	004079	Passenger footrest (1) - Replacement	
3	004015	Footrest - removal and installation	

Rear cover

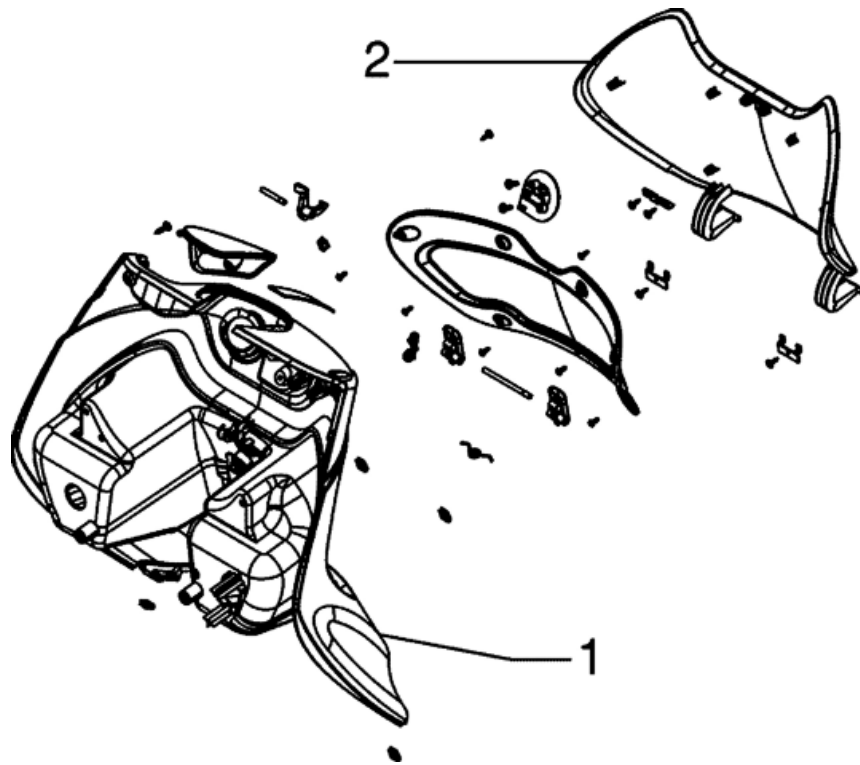

REAR SHIELD

	Code	Action	Duration
1	004065	Front shield rear section - removal and installation	
2	004081	Glove-box lid - Replacement	

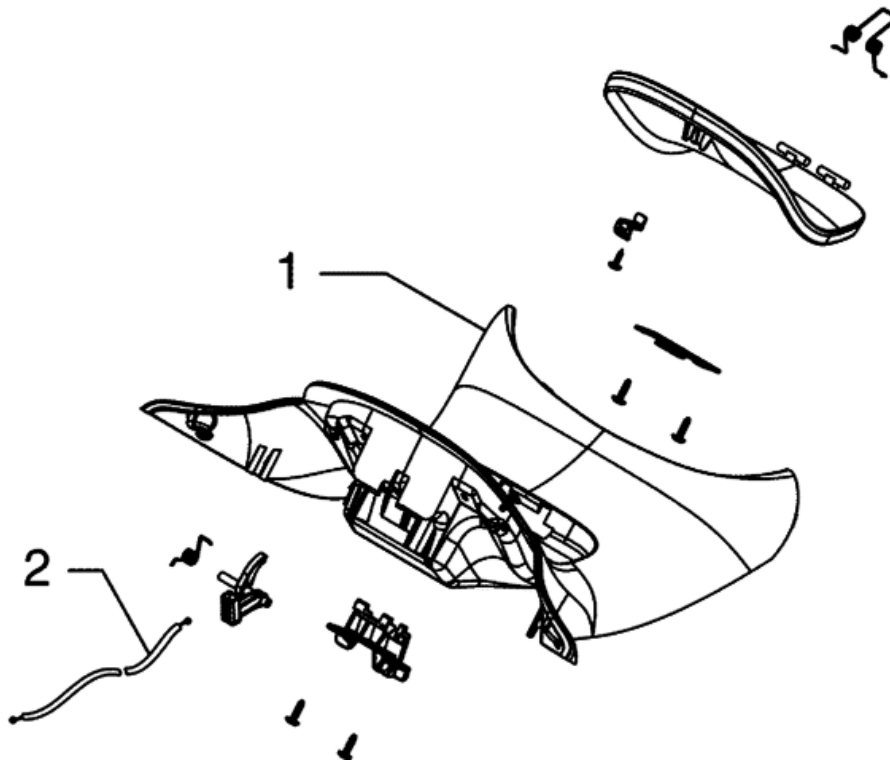
Central cover**CENTRAL COVER**

	Code	Action	Duration
1	004011	Central frame cover - Replacement	
2	002082	Fuel tank cap opening drive - Replacement	

Underseat compartment

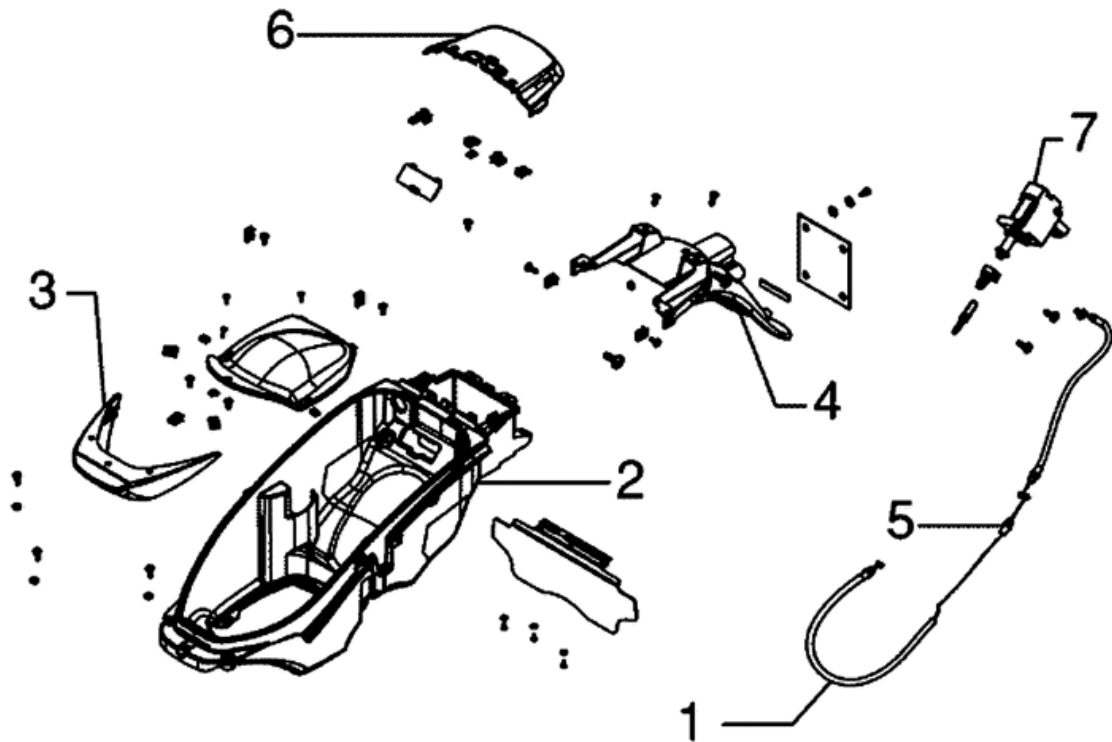

UNDER-SADDLE COMPARTMENT-ELECTRIC SEAT OPENING-LICENCE PLATE SUPPORT

	Code	Action	Duration
1	002083	Saddle opening transmission - replacement Saddle opening transmission - replacement	
2	004016	Helmet compartment - removal and installation	
3	004106	Underseat band - Replacement	
4	004136	License plate holder support - Replacement	
5	004158	Saddle opening splitter - Replacement	
6	005046	Battery cover - change	
7	005099	Electric saddle opening activator - Replacement	

Mudguard

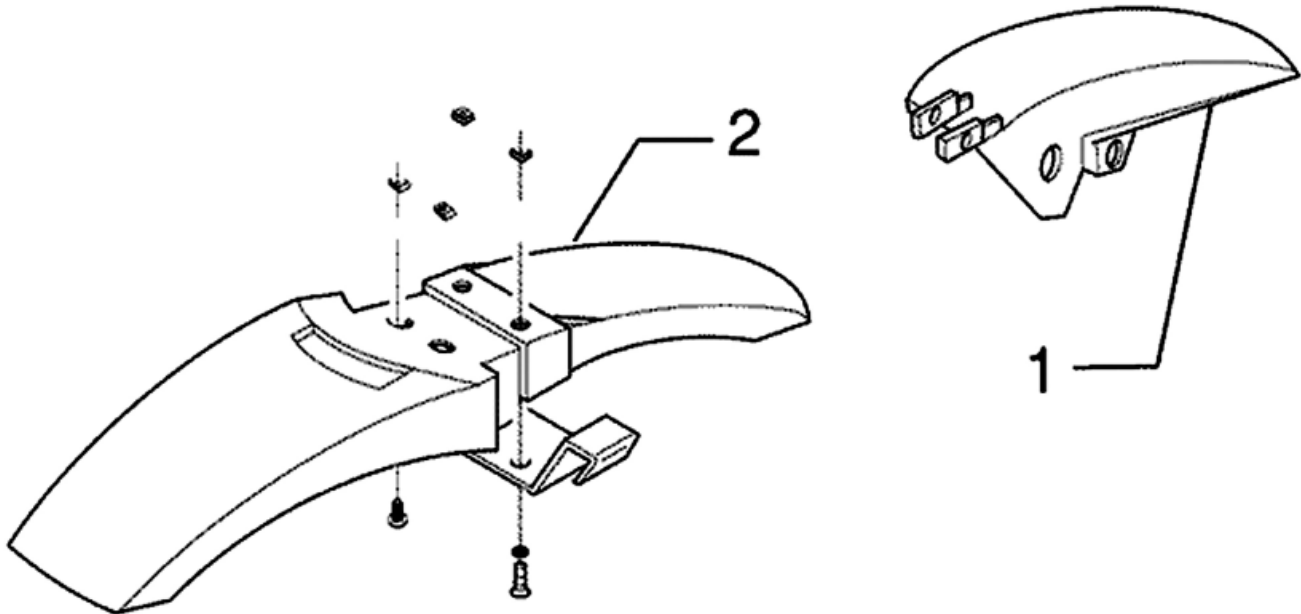

FRONT AND REAR MUDGUARDS

	Code	Action	Duration
1	004009	Rear mudguard - Replacement	
2	004002	Front mudguard - Replacement	

Fuel tank

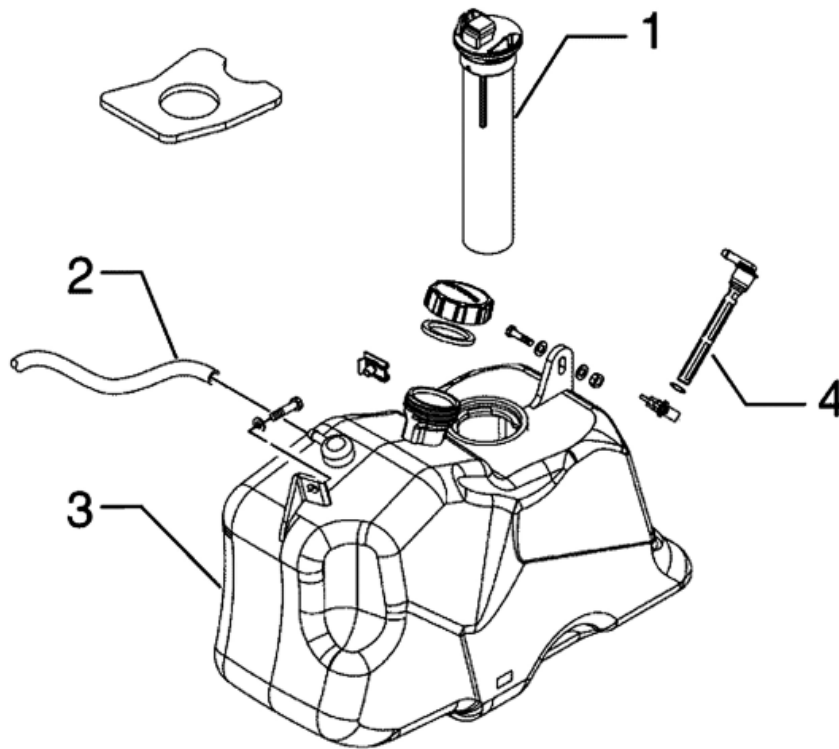

FUEL TANK

	Code	Action	Duration
1	005010	Tank float - Replacement	
2	004109	Fuel tank breather - change	
3	004005	Fuel tank - Replacement	
4	004007	Fuel valve - Replacement	

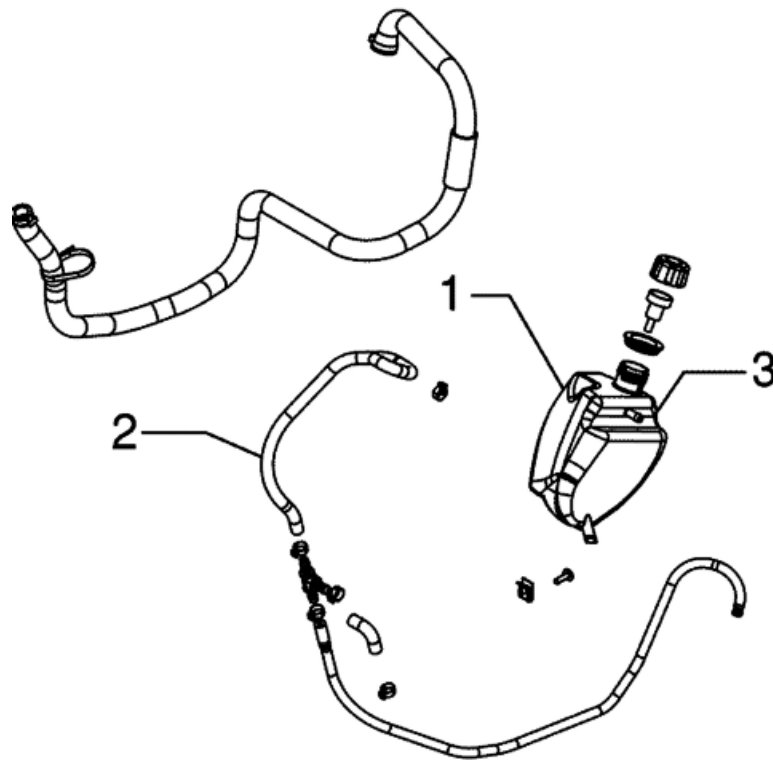
Expansion tank**EXPANSION TANK**

	Code	Action	Duration
1	007001	Expansion tank - Replacement	
2	007013	Radiator expansion tank connection pipe - change	
3	001052	Coolant and air bleeding - Change	

Radiator

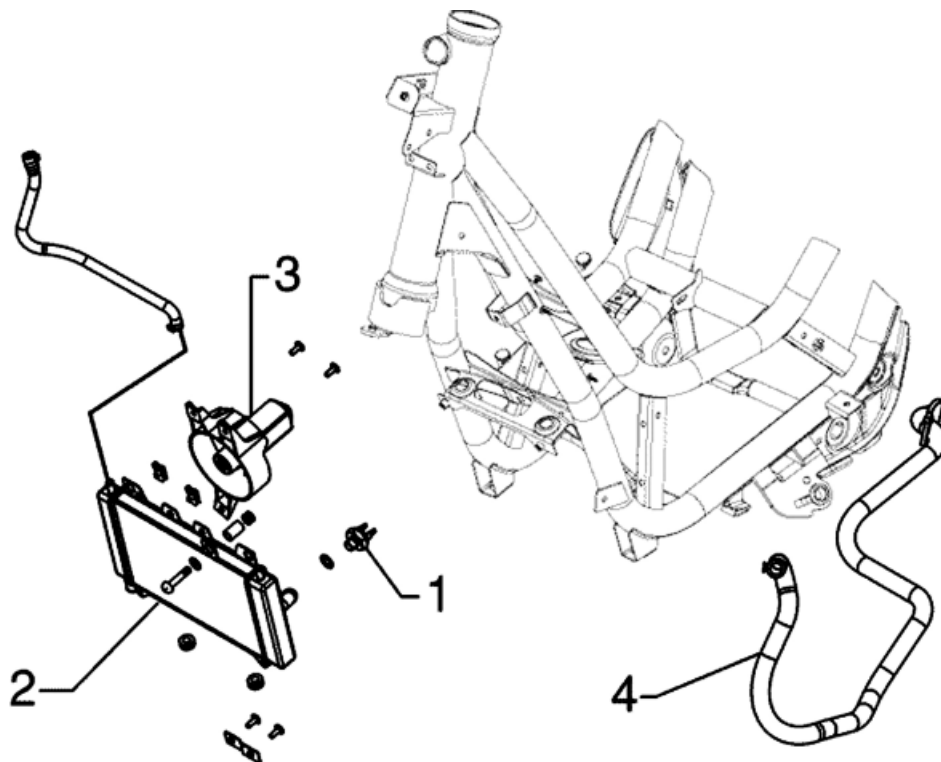

RADIATOR

	Code	Action	Duration
1	007014	Radiator thermal switch - Replacement	
2	007002	Radiator water - Replacement	
3	007016	Complete fan with support - Replacement	
4	007003	Coolant delivery and return pipe - change	

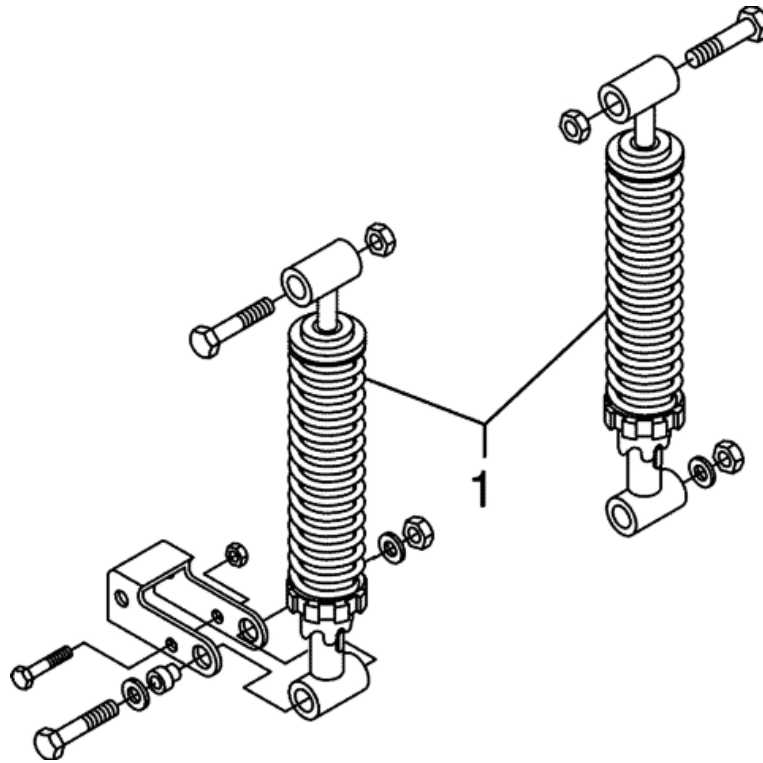
Rear shock-absorber**REAR SHOCK ABSORBER**

	Code	Action	Duration
1	003007	Rear shock absorber - removal and installation	

Steering column bearings

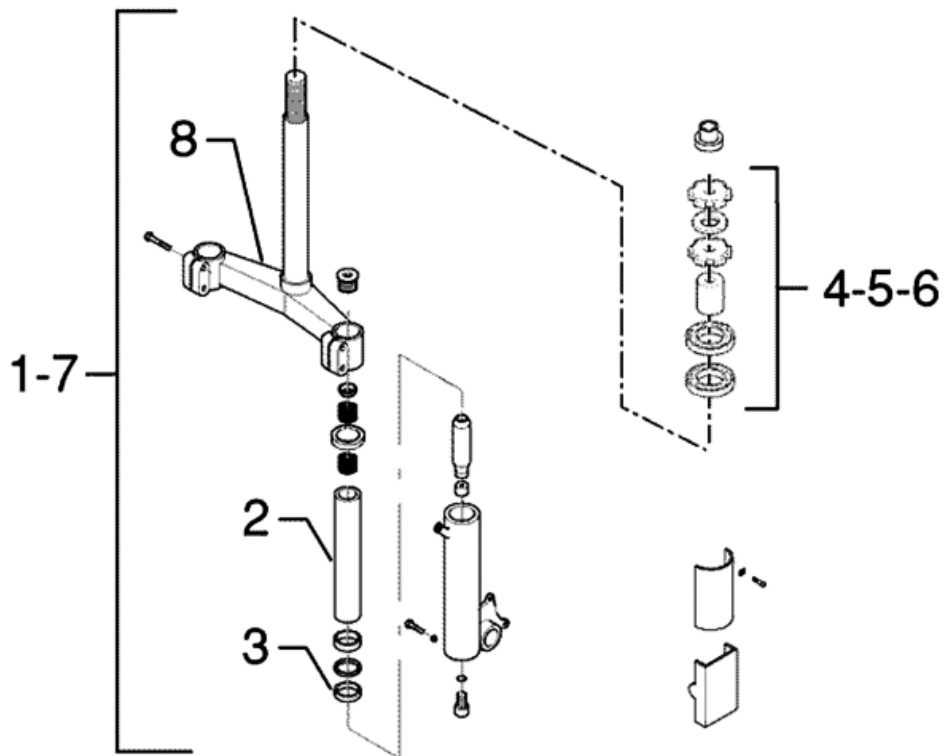

STEERING FIFTH WHEELS

	Code	Action	Duration
1	003051	Fork unit - Replacement	
2	003079	Fork stem - Replacement	
3	003048	Fork oil seal - Replacement	
4	004119	Bearing/upper steering fifth wheel - Replacement	
5	003002	Steering fifth wheel - Replacement	
6	003073	Steering clearance - Adjust	
7	003010	Front suspension - Service	
8	003050	Fork lower plate - Replacement	

Handlebar covers

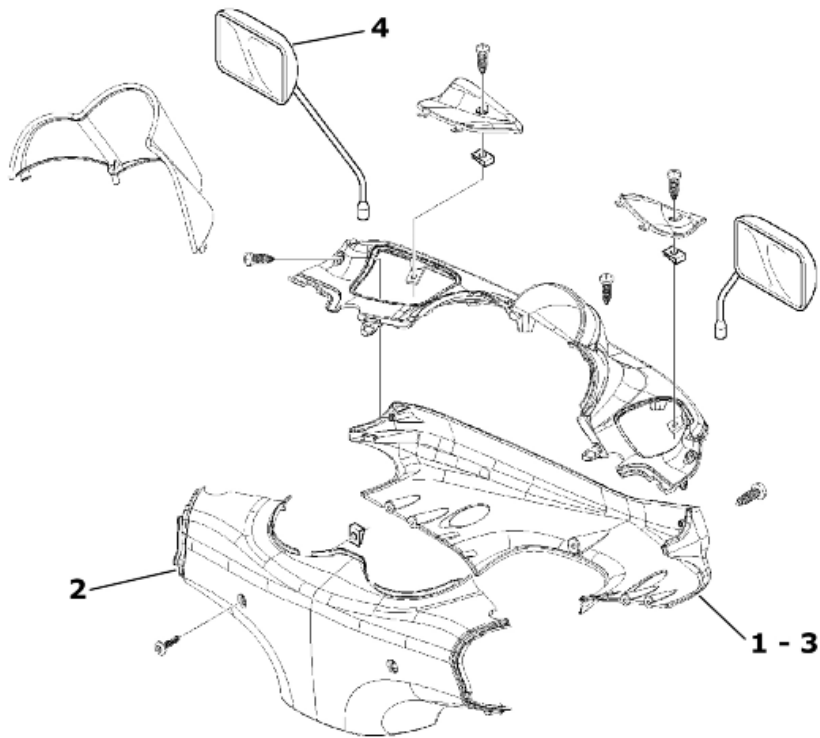

HANDLEBAR COVER

	Code	Action	Duration
1	004018	Handlebar front section - Replacement	
2	004019	Handlebar rear section - Replacement	
3	006013	Handlebar front part - Painting	
4	006014	Handlebar rear part - Painting	

Handlebar components

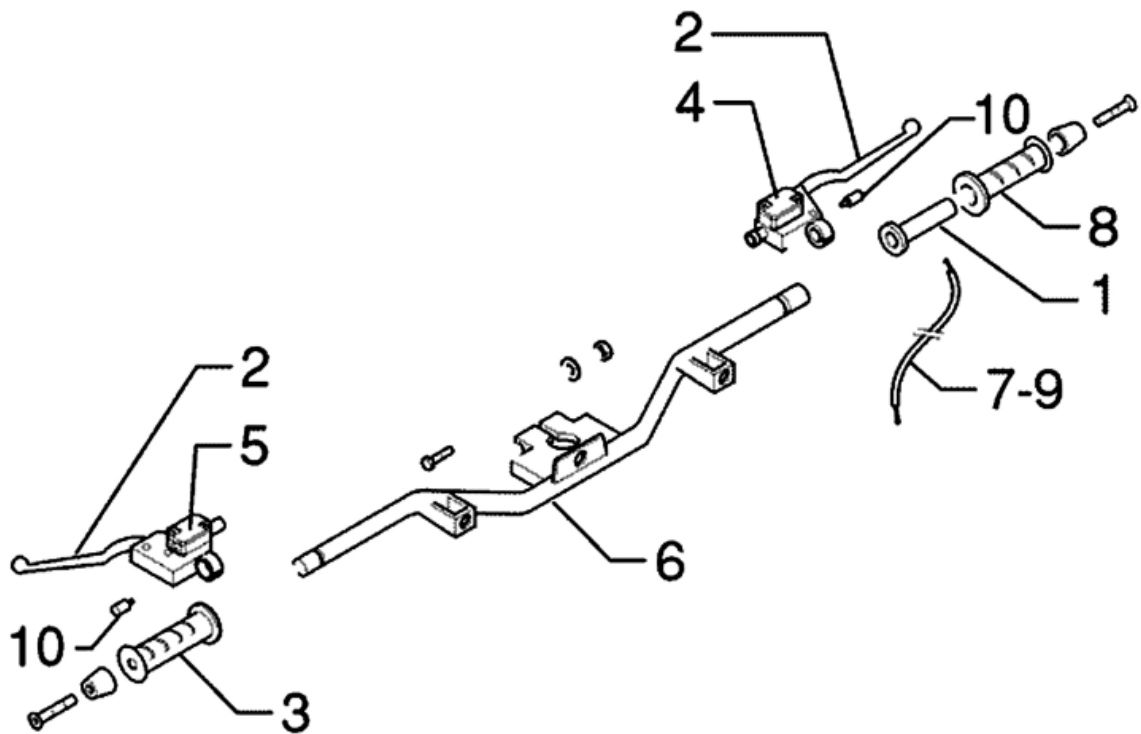

HANDLEBAR COMPONENTS

	Code	Action	Duration
1	002060	Throttle grip - Replacement	
2	002037	Brake or clutch lever - Replacement	
3	002071	Left knob - Replacement	
4	002024	Front brake pump - Removal and Refitting	
5	002067	Rear brake pump - Replacement	
6	003001	Handlebar - Replacement	
7	002063	Complete throttle grip transmission - Replacement	
8	002059	Right-hand knob - Replacement	
9	003061	Accelerator transmission - adjust	
10	005017	Stop switch - Replacement	

Swing-arm

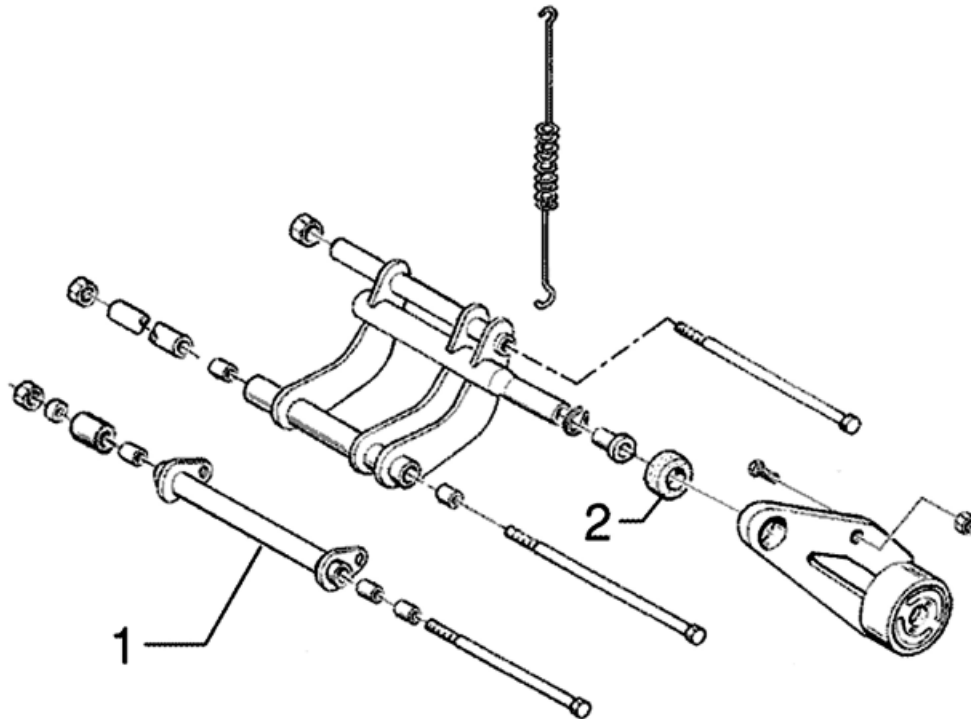

SWINGING ARM

	Code	Action	Duration
1	001072	Swinging arm - Engine-chassis connection - Replacement	
2	004058	Silent block - Replacement	

Brake hoses

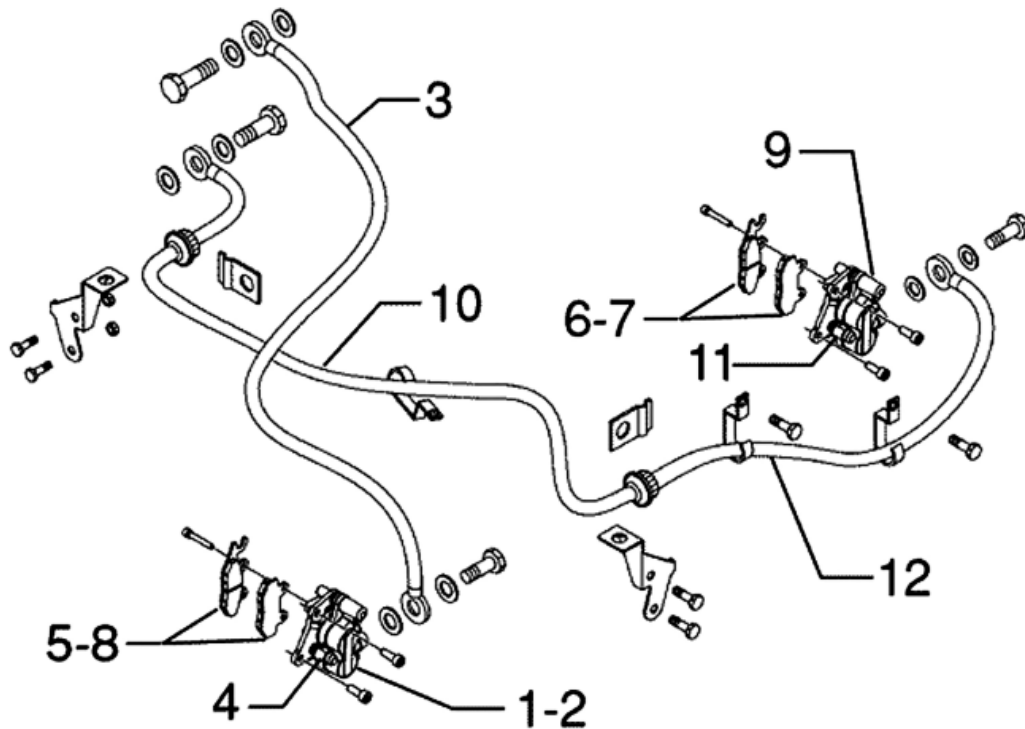

BRAKE PIPING

	Code	Action	Duration
1	002039	Front brake calliper - Replacement	
2	002040	Front brake calliper - Service	
3	002021	Front brake piping - Replacement	
4	002047	Front brake fluid and system bleeding plug - Change	
5	003070	Front brake pads/shoes - Check for wear	
6	003071	Rear brake pads/shoes - Check for wear	
7	002002	Rear brake pads/shoes - Replacement	
8	002007	Front brake pads/shoes - removal and installation	
9	002048	Rear brake calliper - Replacement	
10	002020	Rear brake hose- removal and installation	
11	002080	Rear brake oil bleeding system - Replacement	
12	002081	Rear brake rigid pipes - Replacement	

Seat

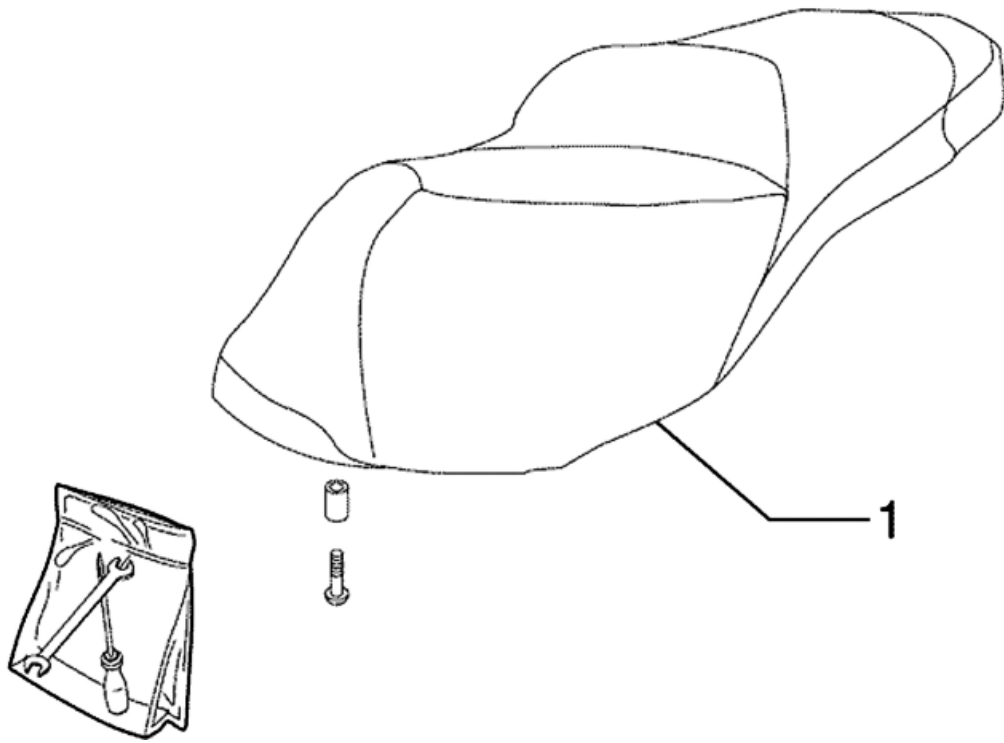

SADDLE

	Code	Action	Duration
1	004003	Saddle - Replacement	

Seat lock

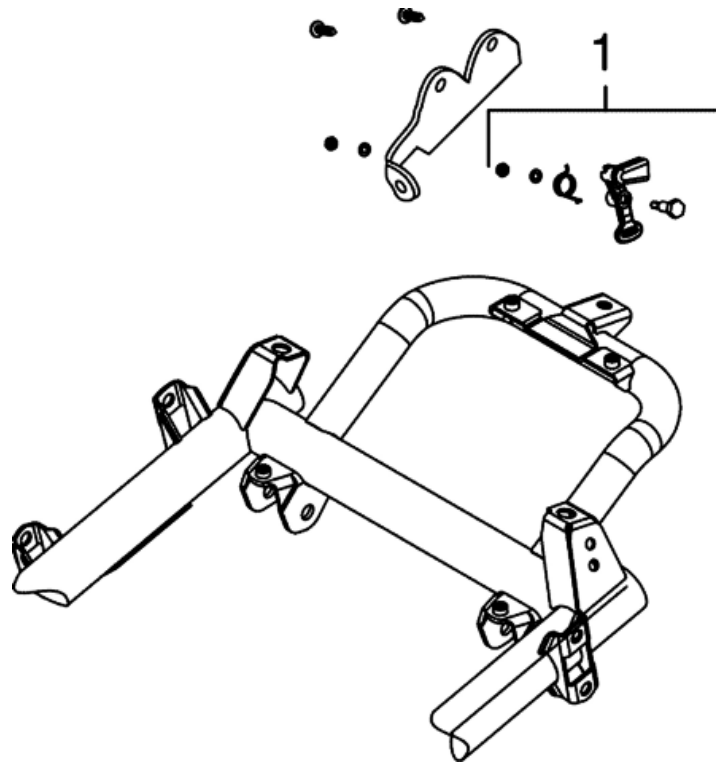

SADDLE CLOSING MECHANISM

	Code	Action	Duration
1	004054	Saddle lock catch - Replacement	

Instrument panel

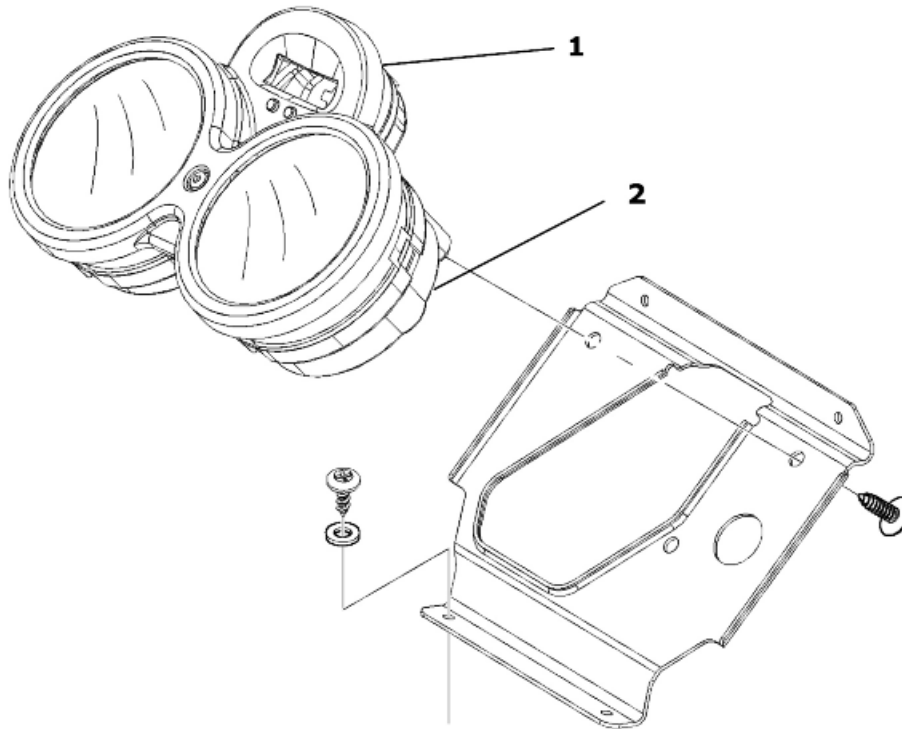

INSTRUMENT PANEL

	Code	Action	Duration
1	005014	Odometer - Replacement	
2	005038	Instrument panel warning light bulbs - Replacement	

Rear rack

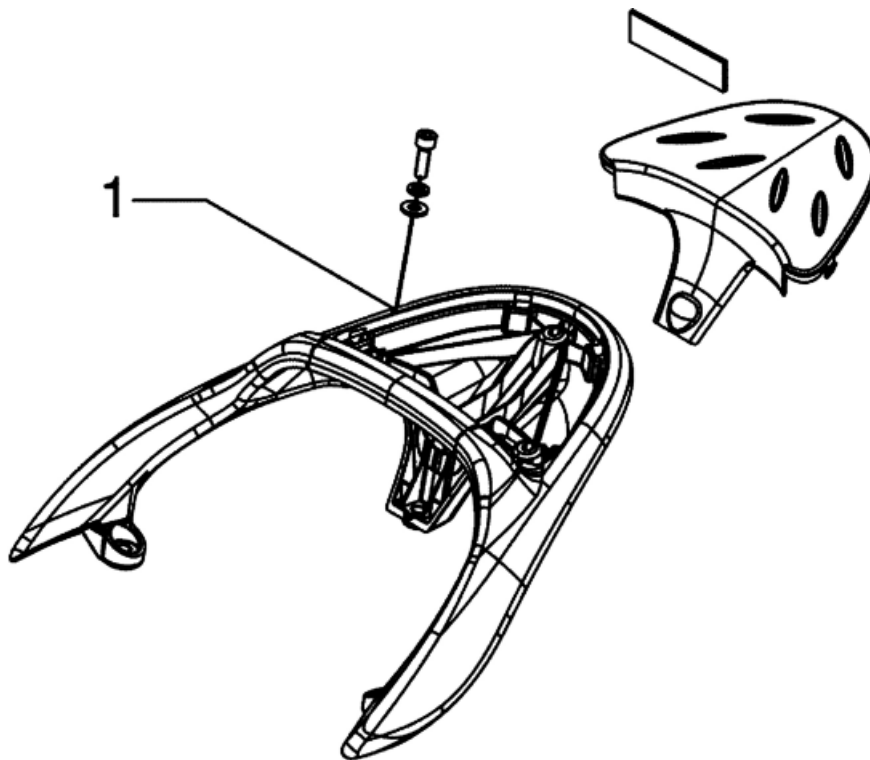

LUGGAGE RACK

	Code	Action	Duration
1	004008	Luggage rack - Replacement	

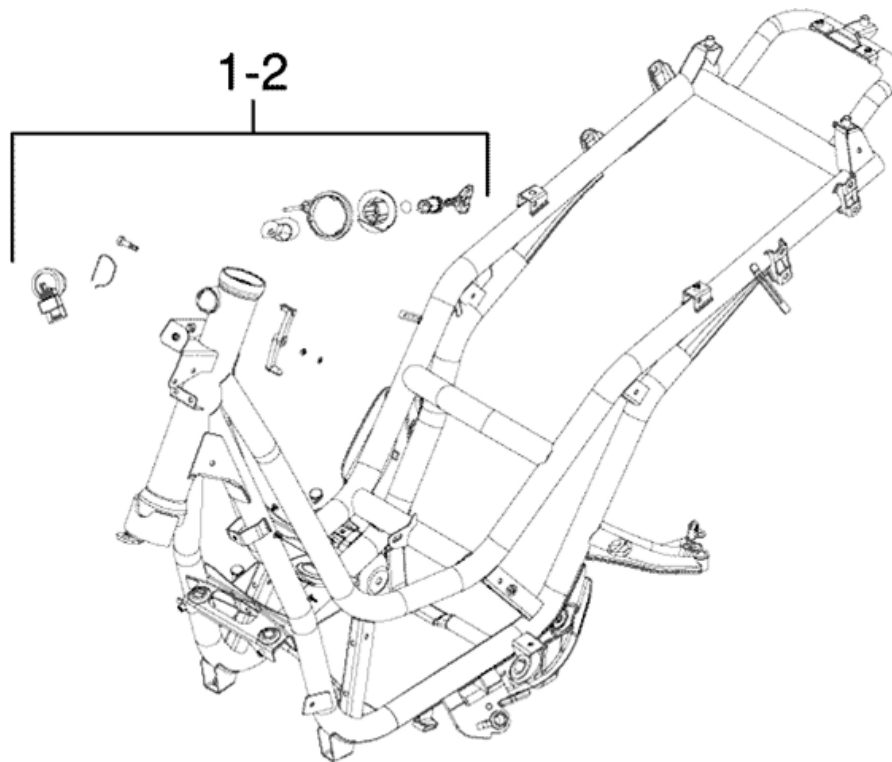
Locks**LOCKS**

	Code	Action	Duration
1	005016	Key switch - Replacement	
2	004010	Antitheft lock - Replacement	

Turn signal lights

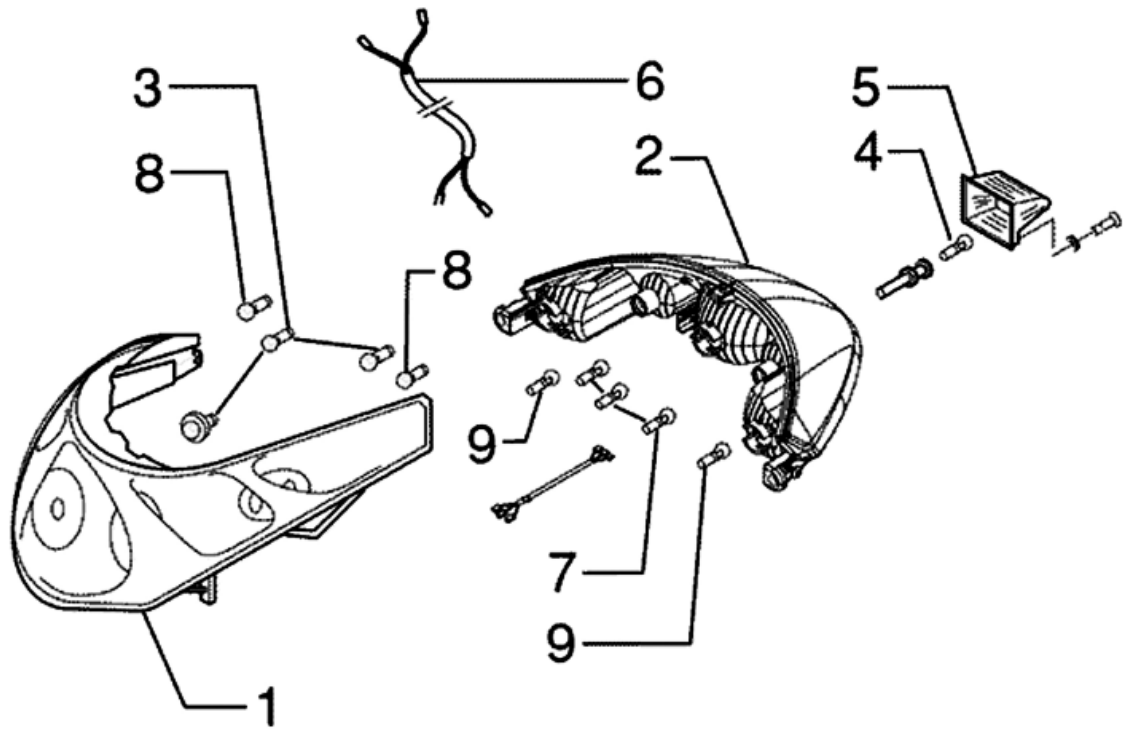

TURN INDICATOR LIGHTS

	Code	Action	Duration
1	005002	Front headlamp - change	
2	005005	Taillight - Replacement	
3	005008	Headlight bulbs - Replacement	
4	005031	Licence plate light bulb - Replacement	
5	005032	Licence plate light glass - Replacement	
6	005044	Front lights cable unit - replace	
7	005066	Rear light bulbs - Replacement	
8	005067	Front turn indicator light - Replacement	
9	005068	Rear turn indicator bulb - Replacement	

Front wheel

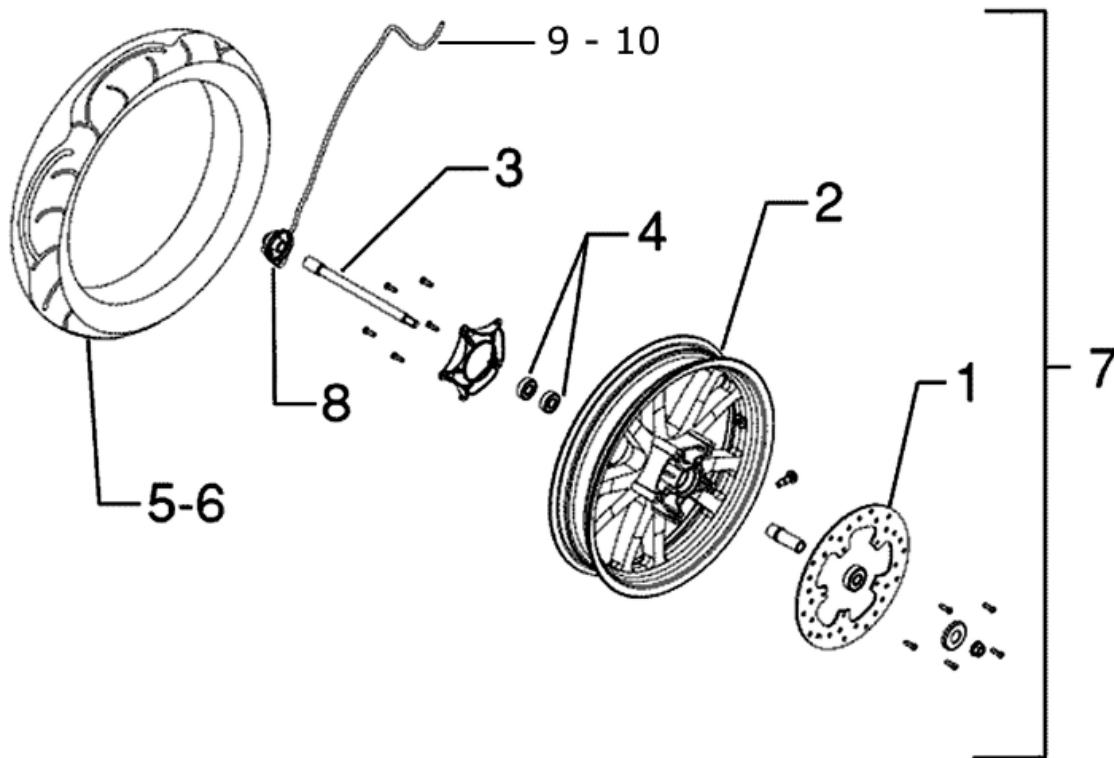
**FRONT WHEEL**

	Code	Action	Duration
1	002041	Brake disc - Replacement	
2	003037	Front wheel rim - removal and installation	
3	003038	Front wheel axle - removal and installation	
4	003040	Front wheel bearings - Replacement	
5	003047	Front tyre - Replacement	
6	003063	Tyre pressure - check	
7	004123	Front wheel - Replacement	
8	002011	Odometer drive- Replacement	
9	002049	Odometer cable - Replacement	
10	002051	Odometer transmission assembly - Replacement	

Grease tone wheel or drive

Please take note that the code has been introduced:

900001 - Tone wheel / drive greasing - 15'.

Never mistake the codes 002011 (movement sensor replacement) and 005089 (tone wheel replacement) in the event of noise of the indicated components. The grease recommended is TUTELA MRM 2 (soap-based lithium grease with Molybdenum disulphide).

In the following points we indicate with an arrow the area to be greased (1 - Drive, 2 - Tone wheel)

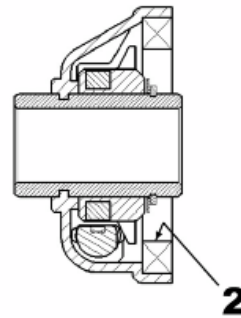
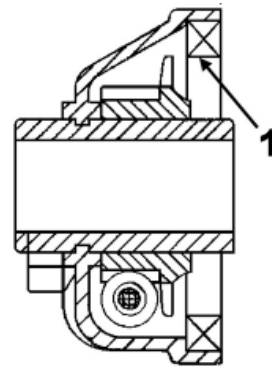

Rear wheel

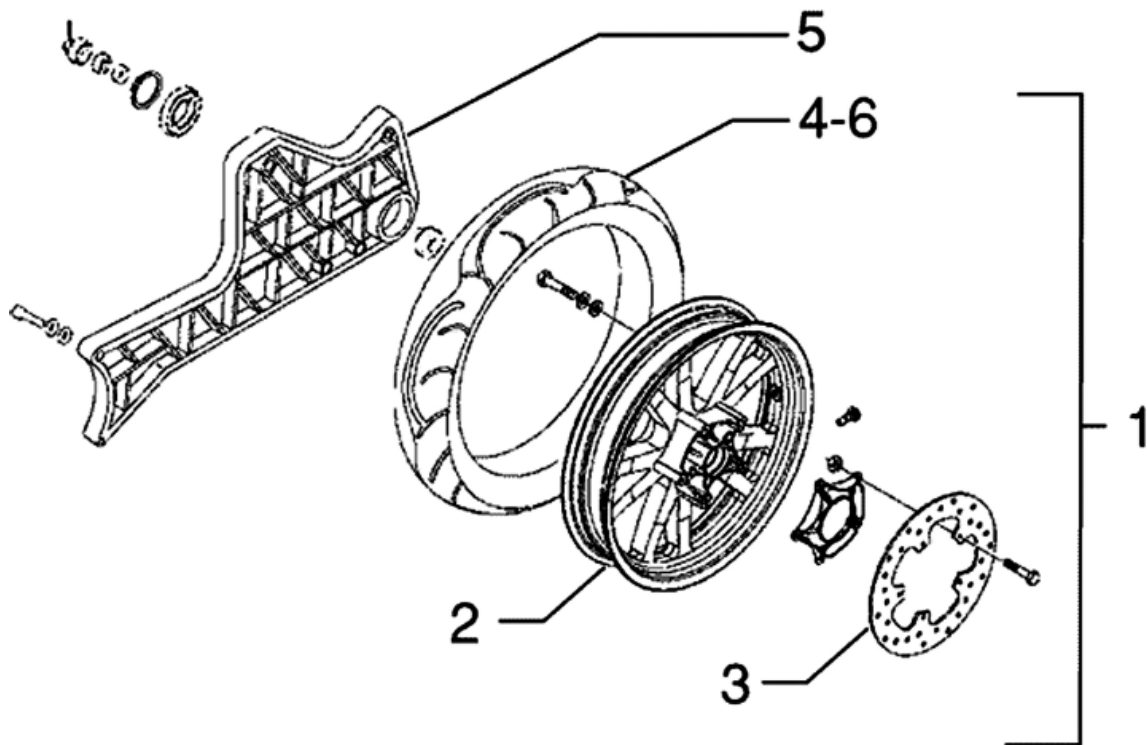

REAR WHEEL

	Code	Action	Duration
1	001016	Rear wheel - Replacement	

	Code	Action	Duration
2	001071	Rear wheel rim - Removal and Refitting	
3	002070	Rear brake disc - Replacement	
4	003063	Tyre pressure - check	
5	003077	muffler/rear shock absorber support arm - Service	
6	004126	Rear wheel tyre - Replacement	

Electric start

Versione 250

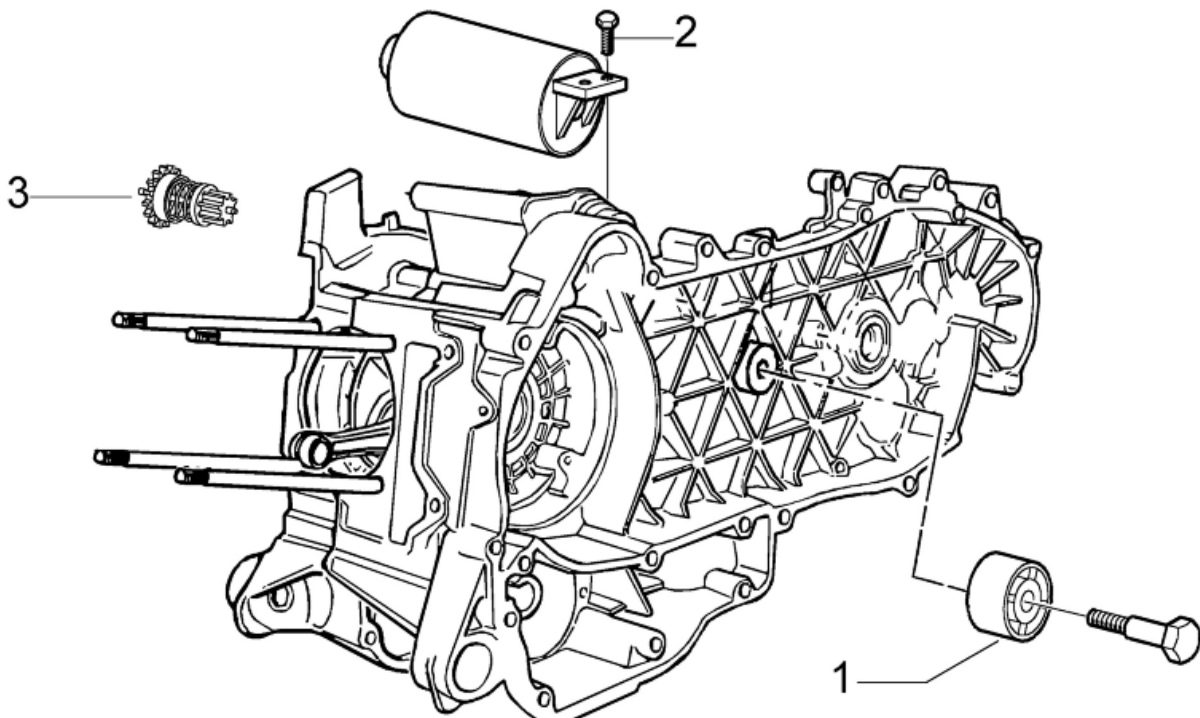

ELECTRICAL START UP

	Code	Action	Duration
1	001141	Belt anti-vibration roller - Replacement	
2	001020	Starter motor - Replacement	
3	001017	Start-up pinion - Replacement	

Versione 125

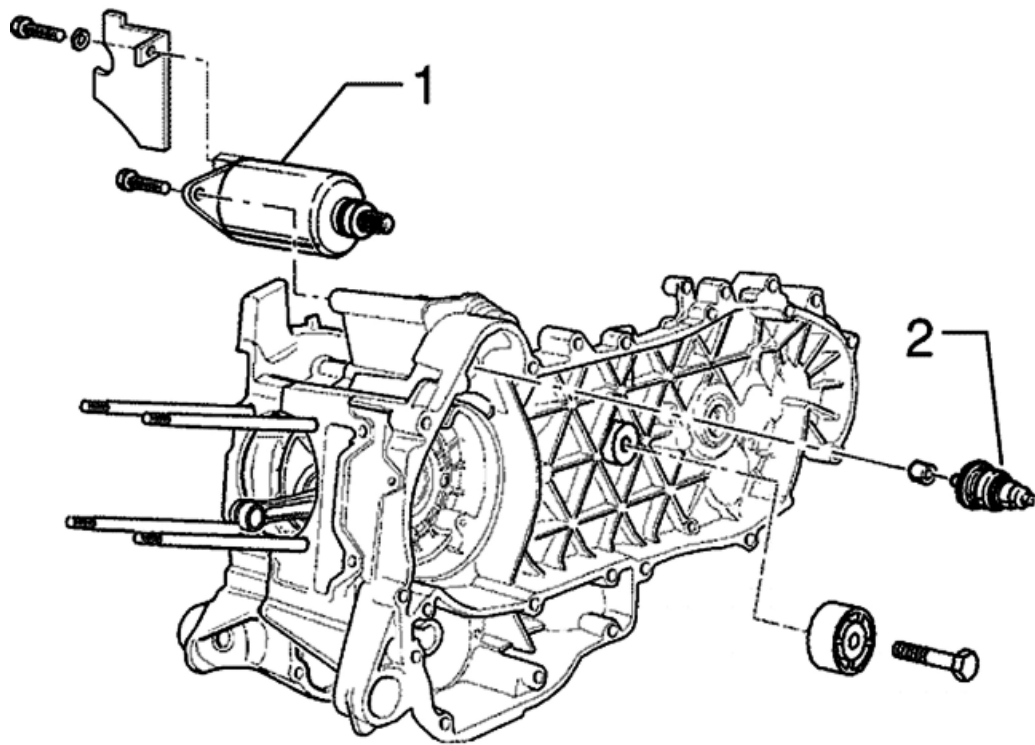

ELECTRICAL START UP

	Code	Action	Duration
1	001020	Starter motor - Replacement	
2	001017	Start-up pinion - Replacement	

Fuel pump

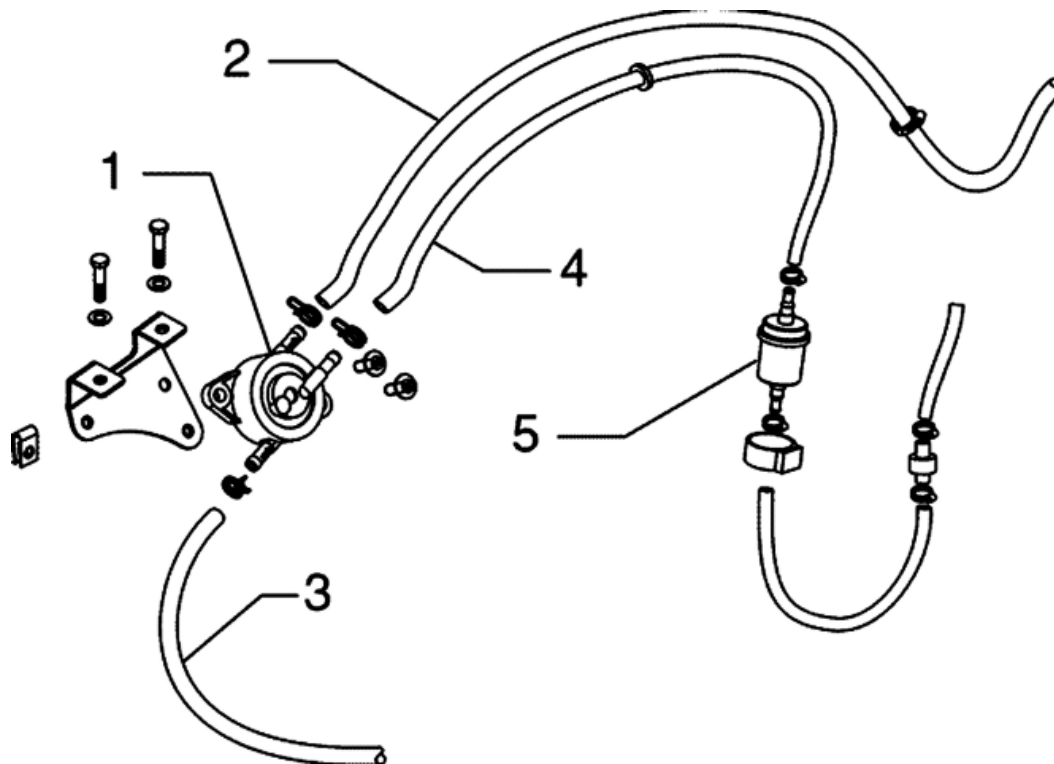
**FUEL PUMP**

	Code	Action	Duration
1	004073	Fuel pump - Replacement	
2	004137	Carburettor pump hose - Replacement	
3	004086	Vacuum fuel pump pipe - Replacement	
4	004089	Tank-pump hose - Replacement	
5	004072	Fuel filter - Replacement	

Electric devices

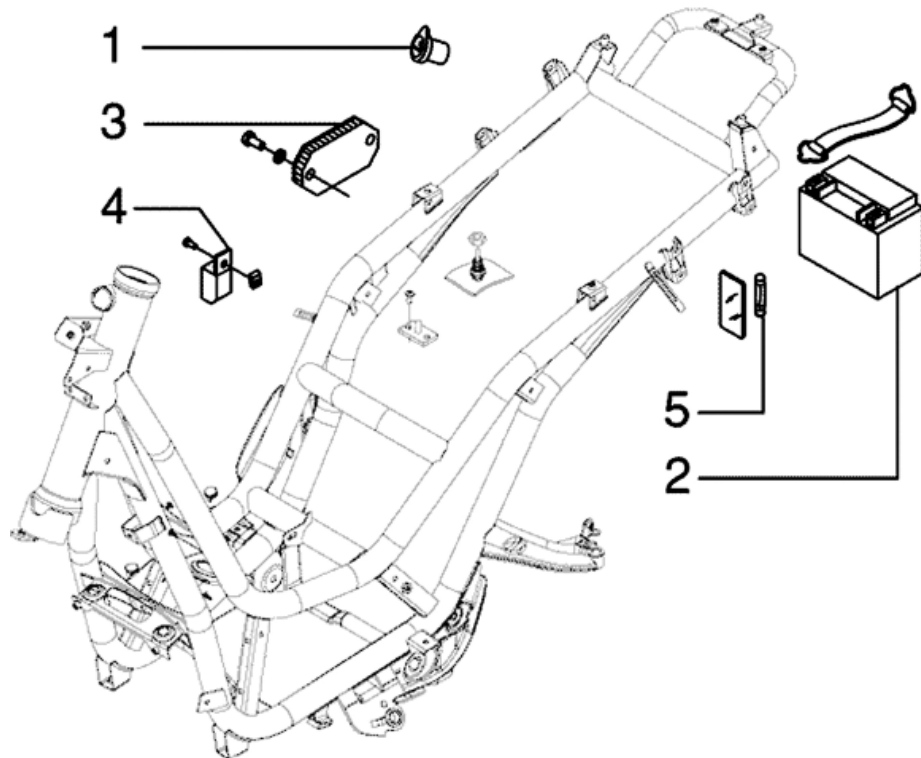

ELECTRIC DEVICES

	Code	Action	Duration
1	004142	Plug socket - Replacement	
2	005007	Battery - change	
3	005009	Voltage regulator - replace	
4	005011	Start-up remote control switch - Replacement	
5	005026	Helmet compartment light - Replacement	

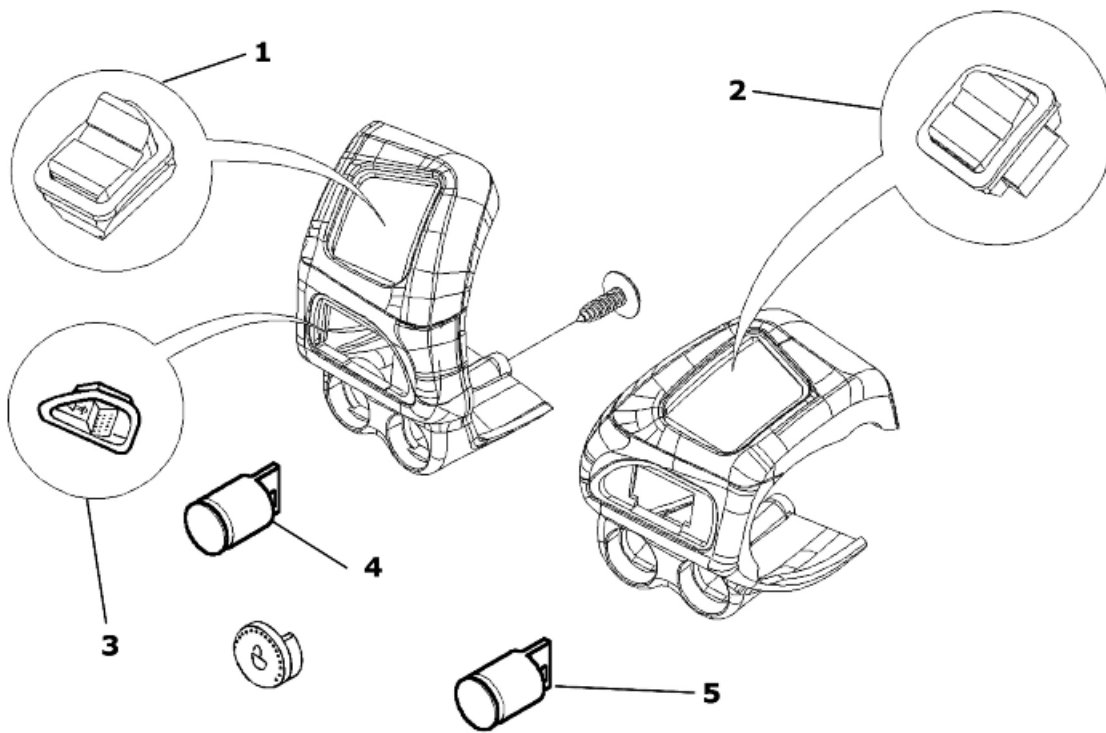

ELECTRIC DEVICES

	Code	Action	Duration
1	005039	Headlight switch - replace	
2	005077	Emergency stop switch - Replacement	
3	005006	Light switch or turn indicators - replace	
4	005040	Horn button - Replacement	
5	005041	Starter button - replace	

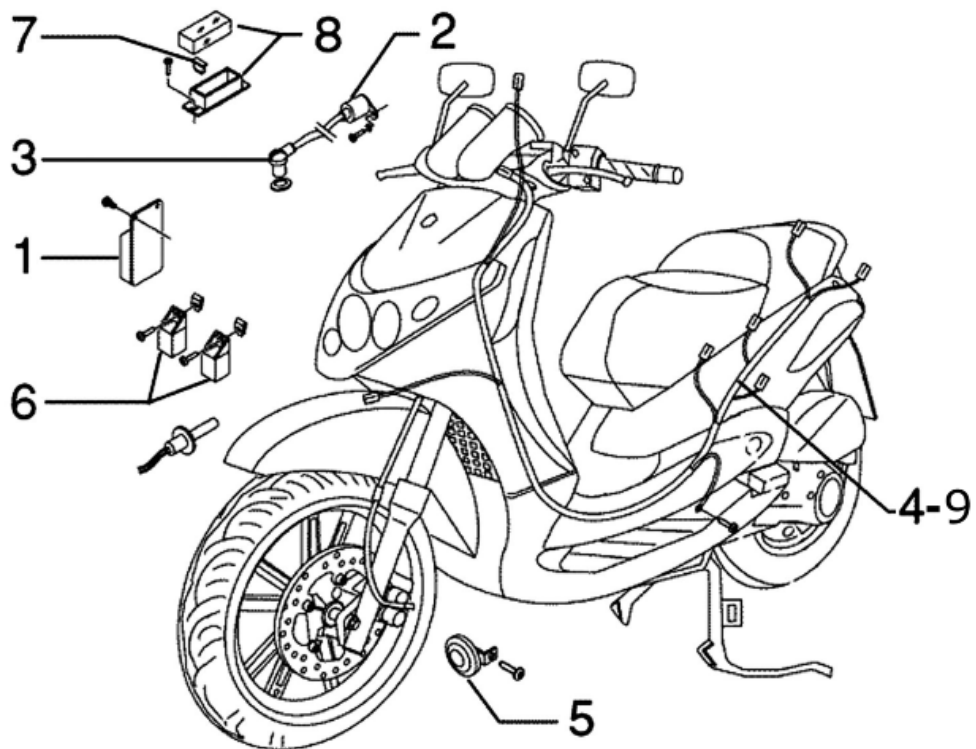

ELECTRIC DEVICES

	Code	Action	Duration
1	001023	Control unit - Replacement	
2	001069	H.V. coil - Replacement	
3	001094	Spark plug hood - Replacement	
4	005001	electric system - change	
5	005003	Horn - Replacement	
6	005035	Headlight remote control - Replacement	
7	005052	Fuse (1) - Replacement	
8	005054	Fuse block (1) - Replacement	
9	005114	Electrical system - Service	

Secondary air box

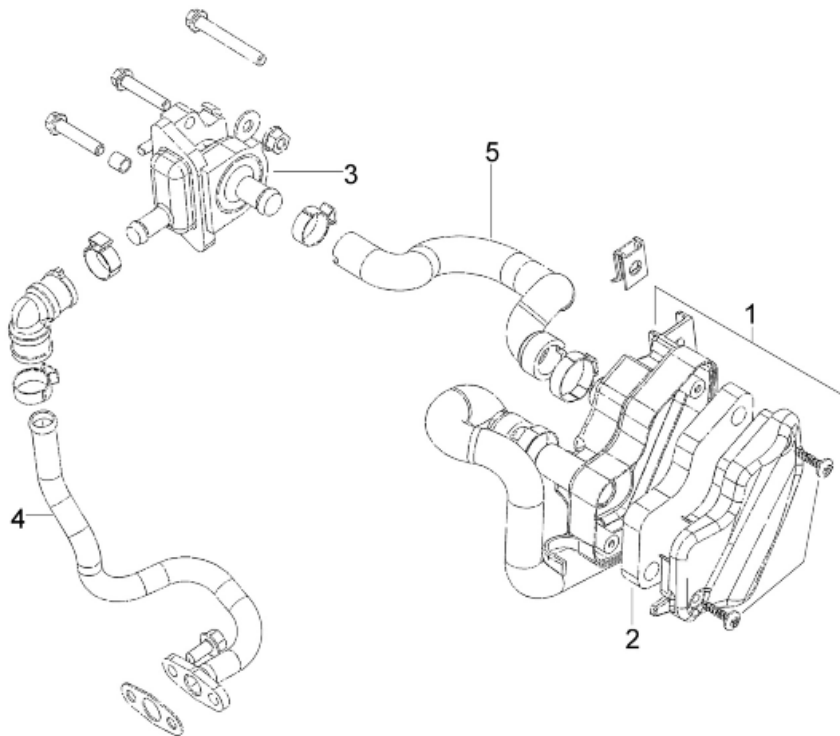

SECONDARY AIR HOUSING

	Code	Action	Duration
1	001162	Secondary air housing - Replacement	
2	001161	Secondary air filter - Replacement / Cleaning	
3	001174	SAS valve - Replacement	
4	001163	SAS valve / Head connection - Replacement	
5	001164	Crankcase secondary air connection - Replacement	